

BUILT RIGHT - PRICED RIGHT

EASTEY

Shrink Packaging Equipment for the Shrinking World

EET2010

Shrink Tunnel



The EET2010 Shrink Tunnel has “the cool side feature” as standard equipment, the outside of the tunnel is cool to the touch. This EET2010 also features electronically controlled air speed velocity control. With bottom air flow adjustment.

Packaging - Processing
Bid on Equipment
1-847-683-7720
www.bid-on-equipment.com

Standard features of the EET2010 include:

- Live roller or stainless steel mesh belt conveyor system
- Solid state temperature control
- 4-directional air flow with variable electronically controlled air velocity speed
- Chamber size 20"W x 10"H x 36"L
- Packages per minute: 20 ppm
- EET2008 - 1" leveling legs
- Bottom air flow adjustment (full on, 1/2 on, or full off)
- Optional slide plates (top + sides) for quick air flow patterning/change over for different packages
- Locking casters
- Full production industrial capabilities

WEIGHT, POWER REQUIREMENTS, DIMENSIONS

SHRINK TUNNEL MODELS	MACHINE DIMENSIONS (in)				MACHINE DIMENSIONS (cm)				VOLTS	AMPS	PHASE	WEIGHT		CRATED SHP WGT			
	W	x	H	x	L	W	x	H				x	L	(lbs)	(kg)	(lbs)	(kg)
EET2010	38	x	51	x	49	96.52	x	129.54	x	124.46	220	40	1	600	273	800	364

TUNNEL CHAMBER, ROLLER AND CONVEYOR DIMENSIONS

MODELS	CHAMBER DIMENSIONS (in)				CHAMBER DIMENSIONS (cm)				ROLLER WIDTH		CONVEYOR LENGTH			
	W	x	H	x	L	W	x	H	x	L	(in)	(cm)	(in)	(cm)
EET2008	20	x	10	x	36	50.80	x	25.40	x	91.44	20	50.80	49	124.46

Packaging - Processing
Bid on Equipment
1-847-683-7720
www.bid-on-equipment.com

EASTEY ENTERPRISES, INC.

21480 - 147th Avenue North, Rogers, MN 55374

Telephone (763) 428-4846 Fax (763) 428-8361 Toll-free (800) 835-9344

www.eastey.com eastey@eastey.com

Copyright © 2002 Eastey Enterprises Inc., All Rights Reserved

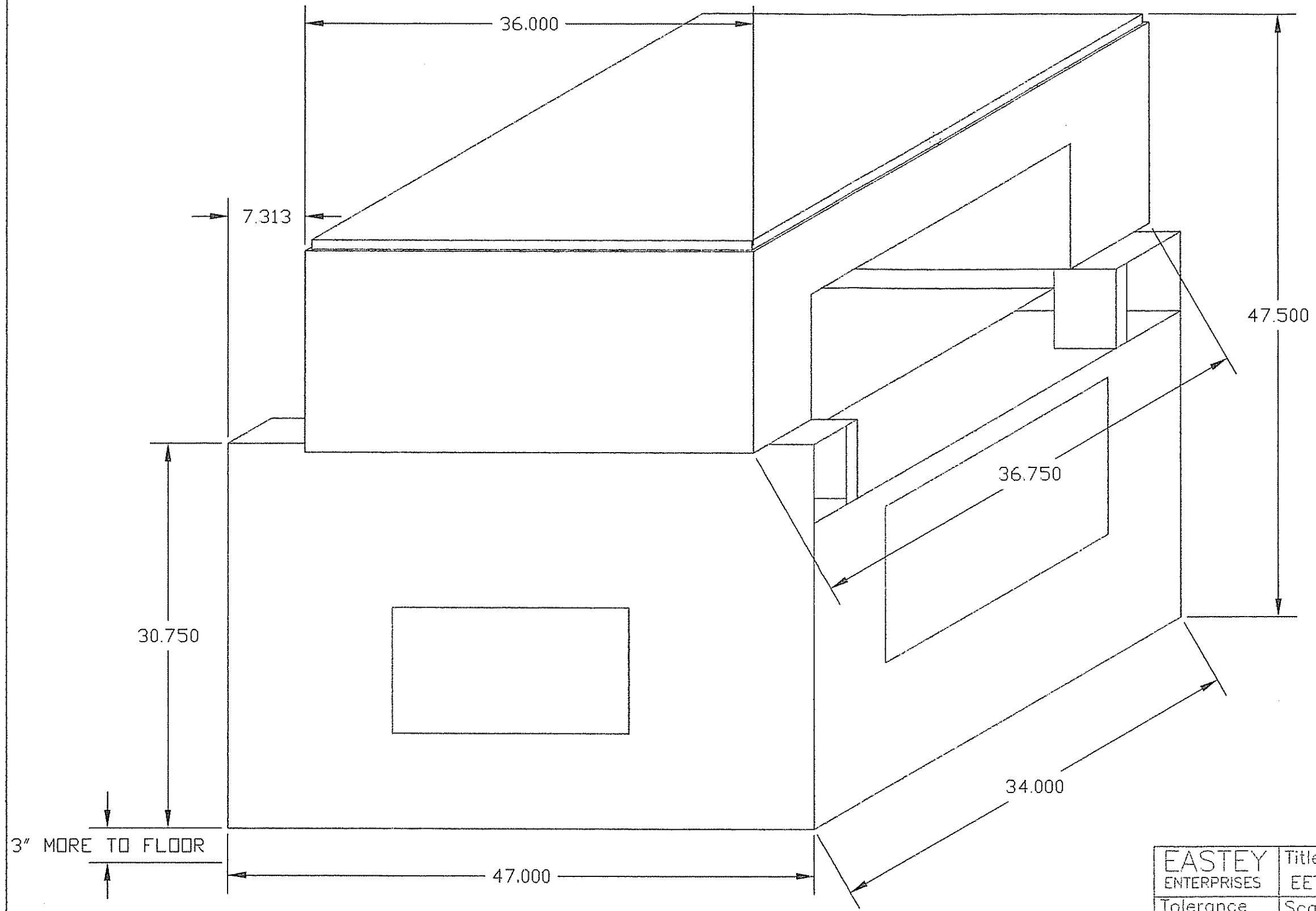

EASTEY ENTERPRISES		Title EET2010 TUNNEL	
Tolerance ±.010 (UNLESS SPECIFIED)		Scale 8:1	Material N/A
Drafter TROY S.		Part Numbers WIREET2010	
CHK By	Date 3-27-07	Part size 0.000 x 0.000	