

BUILT RIGHT - PRICED RIGHT

EASTEY®

Shrink Packaging Equipment for the Shrinking World

EB SERIES SLEEVE WRAPPING SYSTEMS

35", 50", & 70" WIDE SELF CENTERING SEAL SYSTEMS



This system is designed to produce either a "Bull's-eye or Natural Closure" on trayed, individual or multipacked products. The machine utilizes two rolls of single wound film (one top, one bottom) to produce a sleeve around the package. The EB main frame is constructed of 1/4" thick steel and the overall design is extremely rugged. It's unique seal system is a self centering, chain driven mechanism which insures the seal is formed in the center of the product. This design also provides for equal film usage on both the top and the bottom rolls of film. Changeover on the EB is minimal and this equates to less downtime. Once the film is applied by the sleeve wrapper the product passes through a recommended EASTEY Shrink Bundling Tunnel. This provides for a very tight and secure package. Standard sealing systems available are 35", 50", & 70".

***Prices include factory installation
call for details.***

**Packaging - Processing
Bid on Equipment**
1-847-683-7720
www.bid-on-equipment.com

OPERATION SEQUENCE



MANUAL **INLINE**

An operator pushes the product through the film curtain and into the seal area. The film is sealed by a dependable hot knife (Duo Seal®) self centering seal system. Two palm buttons are pushed. The seal head closes and a seal is made. As the seal head opens the takeaway conveyor advances the product to the shrink tunnel.

AUTOMATIC **INLINE**

Products are delivered to the Sleeve Wrapper on a customer supplied powered infeed conveyor. The products should have adequate spacing so that the wrapper can distinguish between each individual product. An electric eye senses the product as it enters the seal area of the wrapper. The eye insures that the product is in the proper sealing position and controls the start/stop of the wrapper's conveyors. The film is sealed by a dependable hot knife (Duo Seal®) self centering seal system. After the seal is formed, the discharge conveyor advances the product to the shrink tunnel.



AUTOMATIC **RIGHT OR LEFT ANGLE**

Products are delivered to the Sleeve Wrapper on a customer supplied powered infeed conveyor. The Sleeve Wrapper infeed conveyor can be right or left mounted. Products should be "choke fed" so once the pusher is activated it can easily remove the product from the conveyor and advance it through the film, on to the dead plate over the outfeed conveyor. The pusher retracts, the seal head closes and the seal is made. The film is sealed by a dependable hot knife (Duo Seal®) self centering seal system. When the seal head opens the pusher can advance the next product through the film, pushing the previous product off the dead plate onto a powered discharge conveyor, which advances the product to the shrink tunnel. Custom product guides may be required for some products.

STANDARD FEATURES & OPTIONS

SEAL WIDTHS IN 35", 50" OR 70"

STANDARD FEATURES ON ALL EB SERIES SLEEVEWRAPPERS

- Powered out feed conveyor system
- 35" seal size = 28" wide x 4' long conveyor - out feed
- 50" seal size = 48" wide x 4' long conveyor - out feed
- 70" seal size = 70" wide x 4' long conveyor - out feed
- 22" seal head height adjustable
- Upper & lower powered film unwind
- Film loading from left or right side
- Upper film rack only 60" off the floor
- Hot knife (Duo Seal®) self centering system
- Casters & Levelers

MANUAL ADDITIONAL STANDARD FEATURES

- 20" slippery surface dead plate infeed
- Electrics on left or right side, customer to specify
- Push 2 button start for seal head

AUTOMATIC INLINE ADDITIONAL STANDARD FEATURES

- Electrics on left side
- Infeed product guides where necessary
- Powered inline, in feed conveyor system
- 35" seal size = 28" wide x 4' long conveyor - in feed
- 50" seal size = 48" wide x 4' long conveyor - in feed
- 70" seal size = 70" wide x 4' long conveyor - in feed

AUTOMATIC RIGHT OR LEFT ANGLE ADDITIONAL STANDARD FEATURES

- Right or left angle powered infeed, with pneumatic product pusher with adjustable return stroke lengths
- Limit switch in pusher area to start cycle once the product is in sealing position
- Dead plate mounted after seal area to stabilize the products
- Infeed product guides where necessary



GENERAL OPTIONS

- Flat polyurethane or stainless steel Infeed Tray with Electrical Box on Left or Right and Push Buttons on end, approximately 18 in to 24 in Depth / 45.72 cm to 60.96 cm Depth - manual sleeve wrapper only.
- Non Standard Voltage
- Side mounted powered film unwind (at floor level) w/inverter
- Wipe down rollers, adjustable
- Extra set of Start/Stop push buttons, stand mounted
- Infeed & outfeed conveyor can be lengthened
- Counter for multiple pushes before seal is made - left or right angle sleeve wrappers only

MODEL	SEAL DIMENSION		AIR REQ.	MACHINE DIMENSIONS			POWER REQ.			WEIGHT
	WIDTH	x HEIGHT		W	x H	x L	VOLTS	PHASE	AMPS	
EB35	35 in	x 22 in	3.5 CFM	62 in x 76 in x 69 in - Manual/98 In Auto			220v	1	10	2500 lbs.
	89 cm	x 56 cm	60 PSI	158 cm x 193 cm x 175 cm/249 cm						1136 kg
EB50	50 in	x 22 in	3.5 CFM	77 in x 76 in x 69 in - Manual/98 In Auto			220v	1	15	3000 lbs.
	127 cm	x 56 cm	70 PSI	196 cm x 193 cm x 175 cm/249 cm						1364 kg
EB70	70 in	x 22 in	3.5 CFM	97 in x 76 in x 69 in - Manual/98 In Auto			220v	1	20	3500 lbs.
	178 cm	x 56 cm	70 PSI	246 cm x 193 cm x 175 cm/249 cm						1591 kg

All above information is based on equipment with standard features, and a hot knife seal system (Duo Seal® System).

For all sleeve wrappers being ordered with options - see quote for power requirements.

UPPER POWER FILM UNWIND

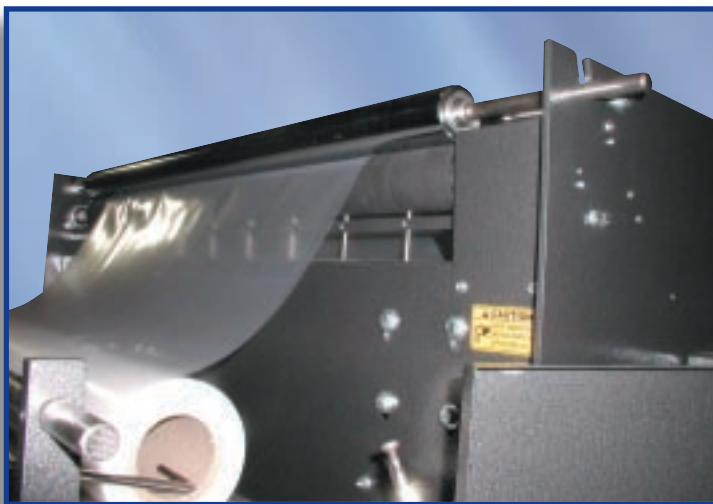

**Shrink Packaging
Equipment
for the
Shrinking World**

**CHOOSE AN EASTEY COMPANION SHRINK TUNNEL.
SELECT FROM A VARIETY OF EASTEY SHRINK TUNNELS.**

Packaging - Processing

Bid on Equipment

1-847-683-7720

www.bid-on-equipment.com

FOR THE SHRINKING WORLD

EASTEY®

EASTEY ENTERPRISES, INC.

21480 147TH AVE. NO.

ROGERS, MN 55374

PHONE: 763/428-4846

FAX: 763/428-8361

TOLL FREE: 800/835-9344

www.eastey.com

eastey@eastey.com

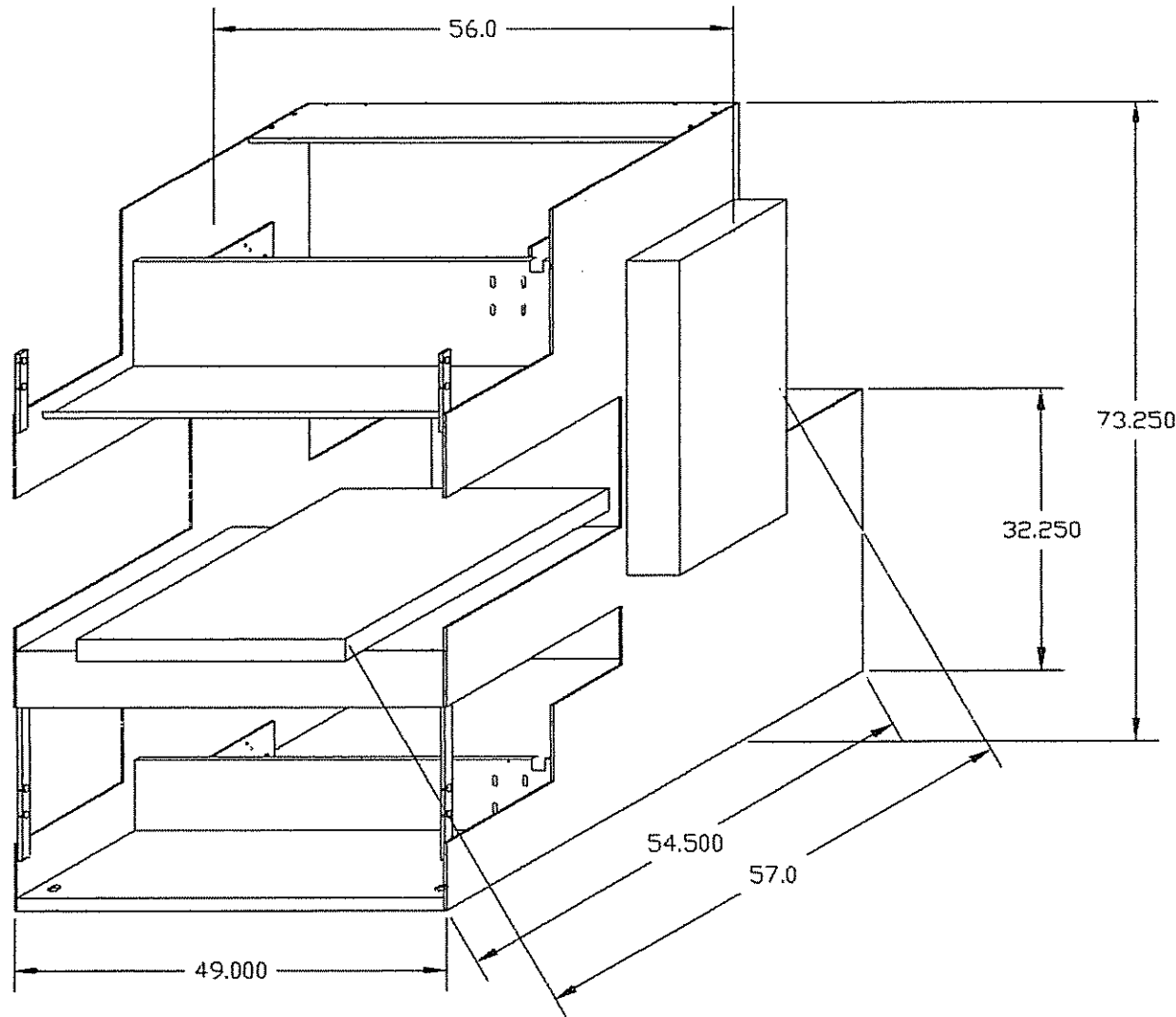

ALL DIMENSIONS ARE IN INCHES	EASTEY ENTERPRISES	Title		
		FRAME STANDARD 30		
	ALL TOLERANCES TO BE ±.01 UNLESS OTHERWISE SPECIFIED	Tolerance ±.010 (UNLESS SPECIFIED)	Scale 1:14	Material N/A
	FINISH - NONE	Drafter TROY S.	Part Numbers EBM30	
	CHK By	Date 9-19-05	Part size 0.000 x	

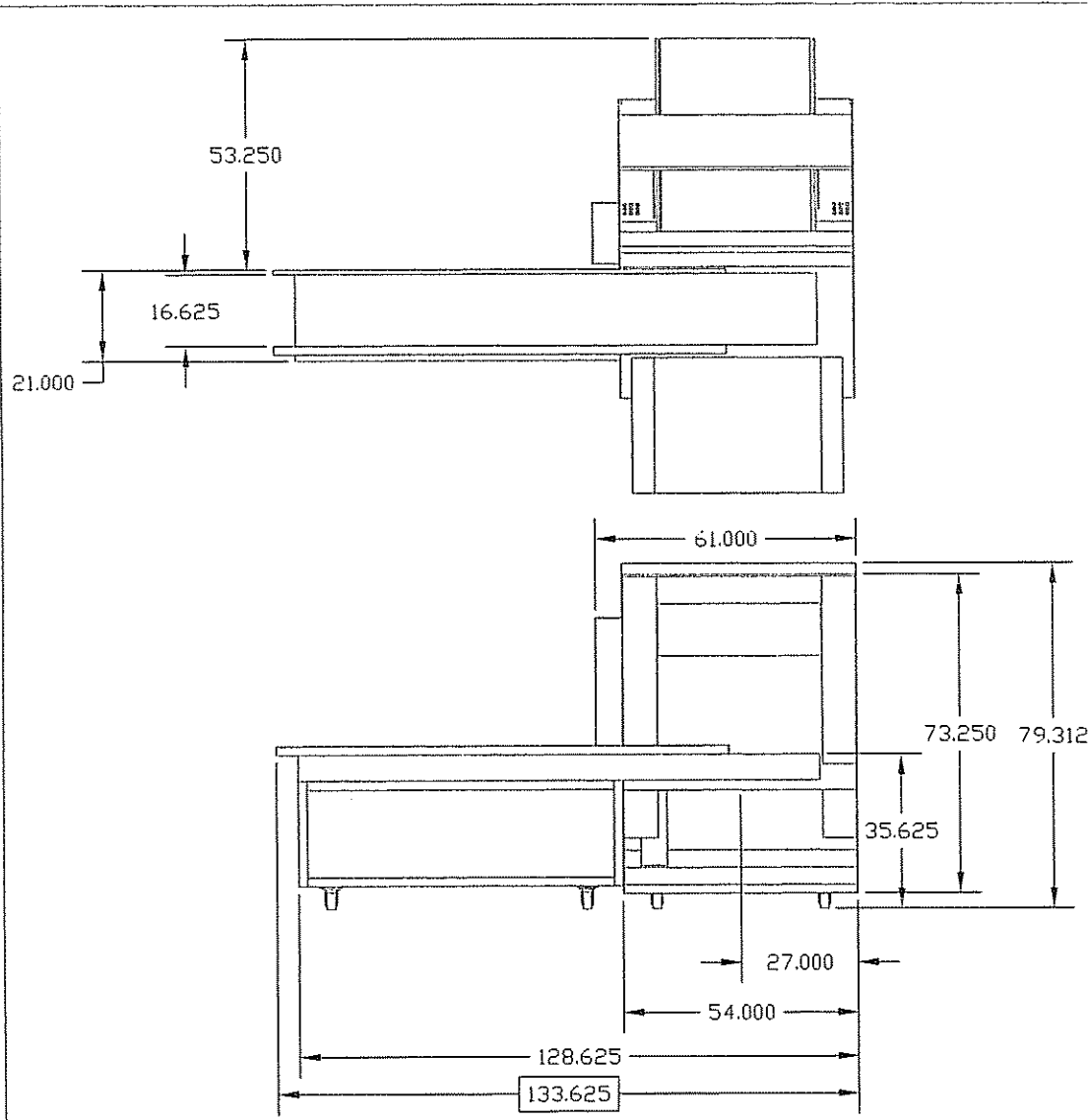

REV	DESCRIPTION	REVISIONS	DATE	APPROVED

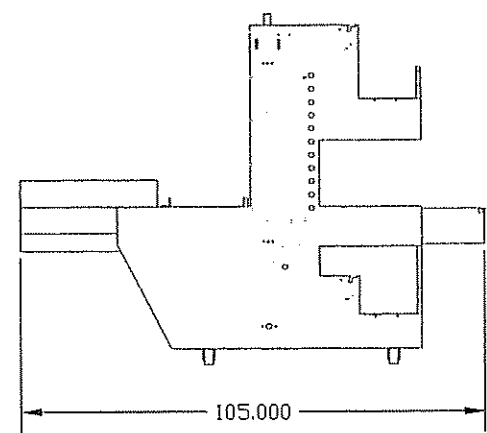

EASTEY ENTERPRISES	Title EB35LA LEFT ANGLE	
Tolerance ± 0.10 <small>(UNLESS SPECIFIED)</small>	Scale 1:2b	Material N/A
Drafter TROY S.	Part Numbers EB35LA	
CHK By	Date 2-27-06	Part size 0.000 x 0.000

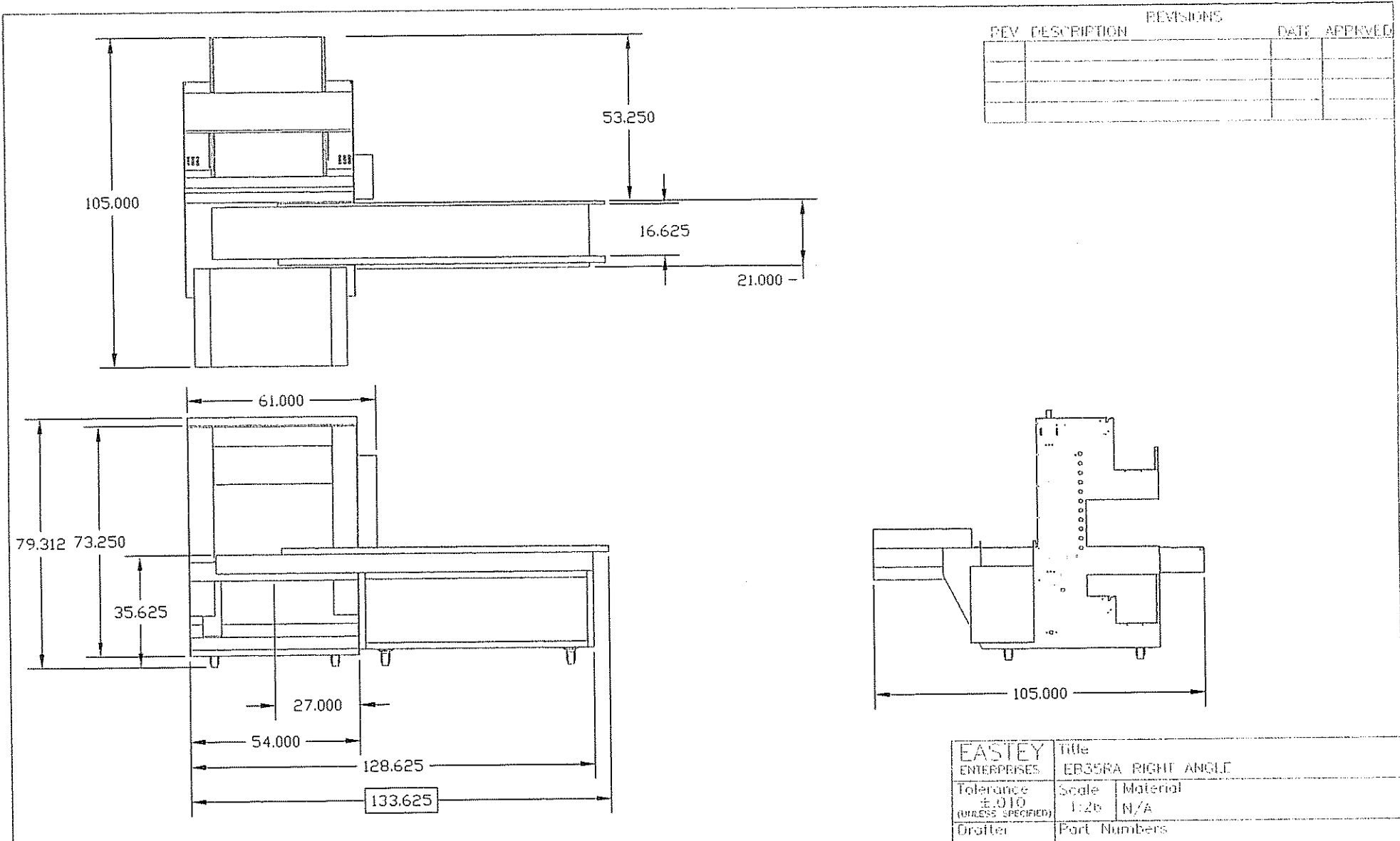

REV	DESCRIPTION	REVISIONS	DATE	APPROVED

EASTEY ENTERPRISES		Title
Tolerance ±.010 (UNLESS SPECIFIED)		EB35RA RIGHT ANGLE
Drafter	Scale	Material
TROY S.	1:2b	N/A
CHIC By		Part Numbers
Date		EB35RA
2-27-06		Part size
		0.000 x 0.000

Packaging - Processing
Bid on Equipment
 1-847-683-7720
 www.bid-on-equipment.com

REV	DESCRIPTION	REVISIONS	DATE	APPRVED

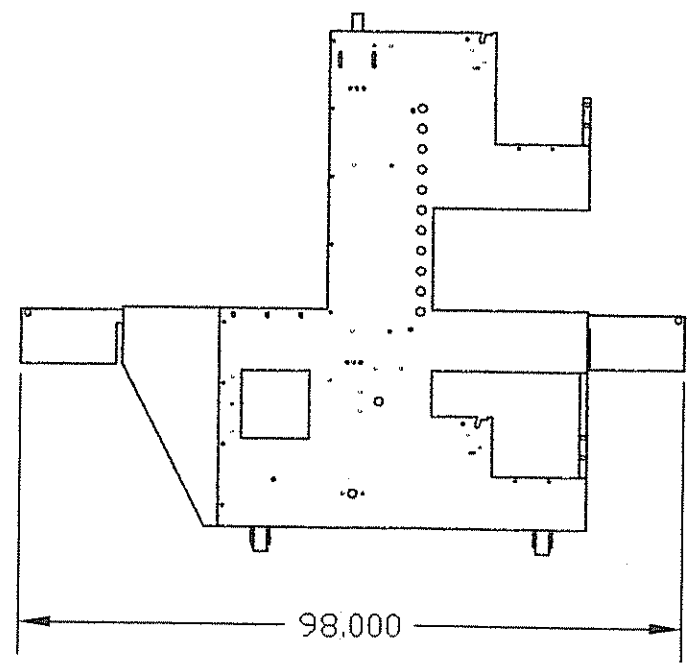
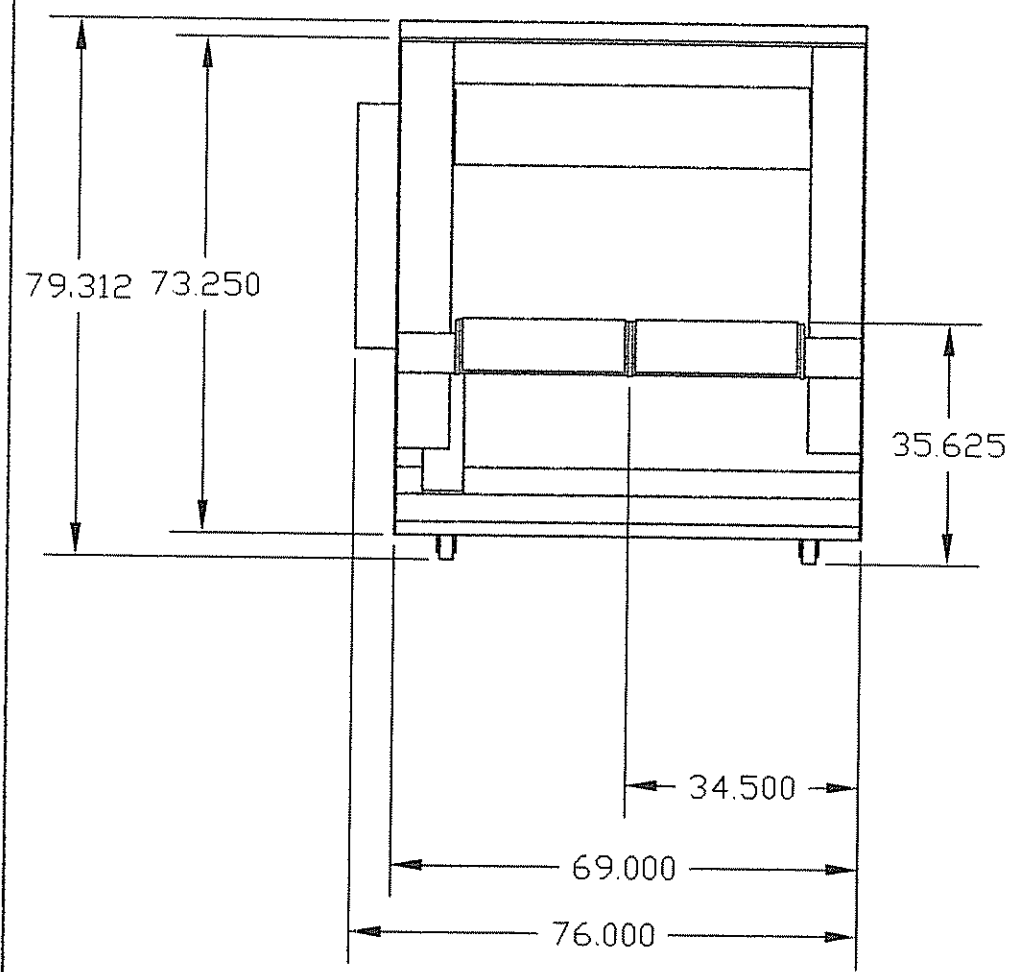
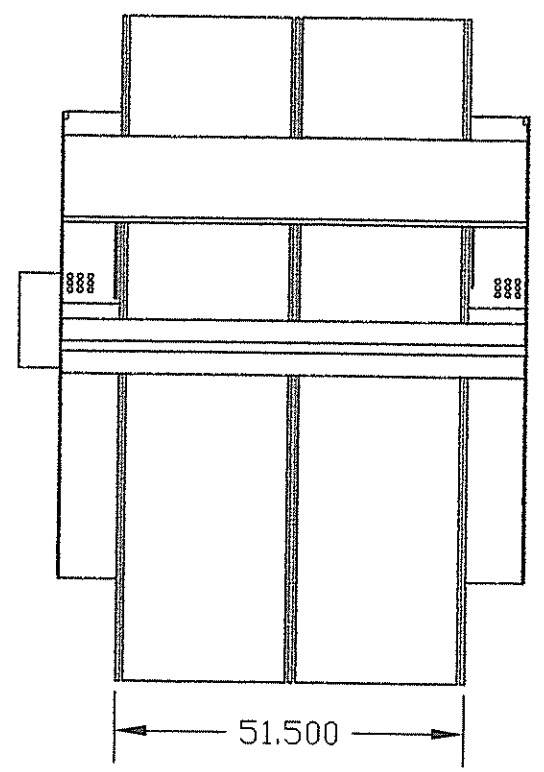

EASTEY ENTERPRISES		Title EB50A BELT IN BELT OUT	
Tolerance ±.010 (UNLESS SPECIFIED)		Scale 1:26	Material N/A
Drafter TROY S.		Part Numbers EB50A	
CHK By	Date 12-13-05	Part size 0.000 x 0.000	

REV		DESCRIPTION	REVISIONS		DATE	APPRVED

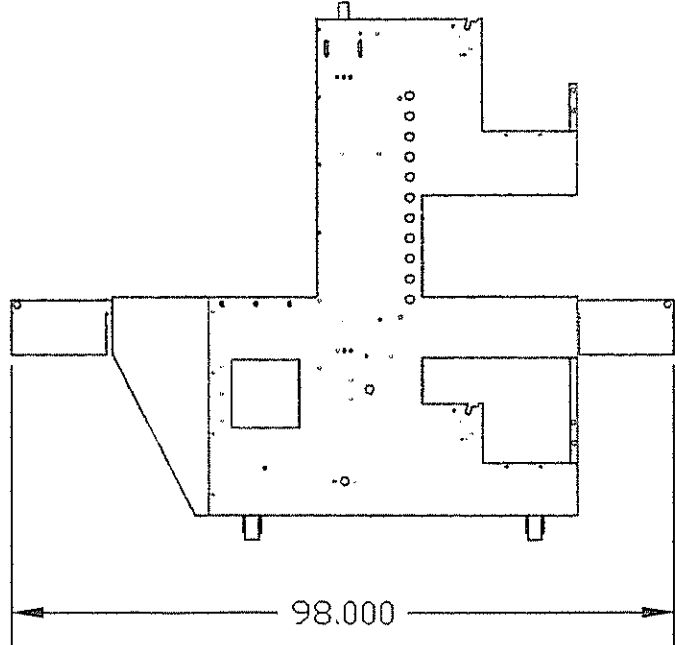
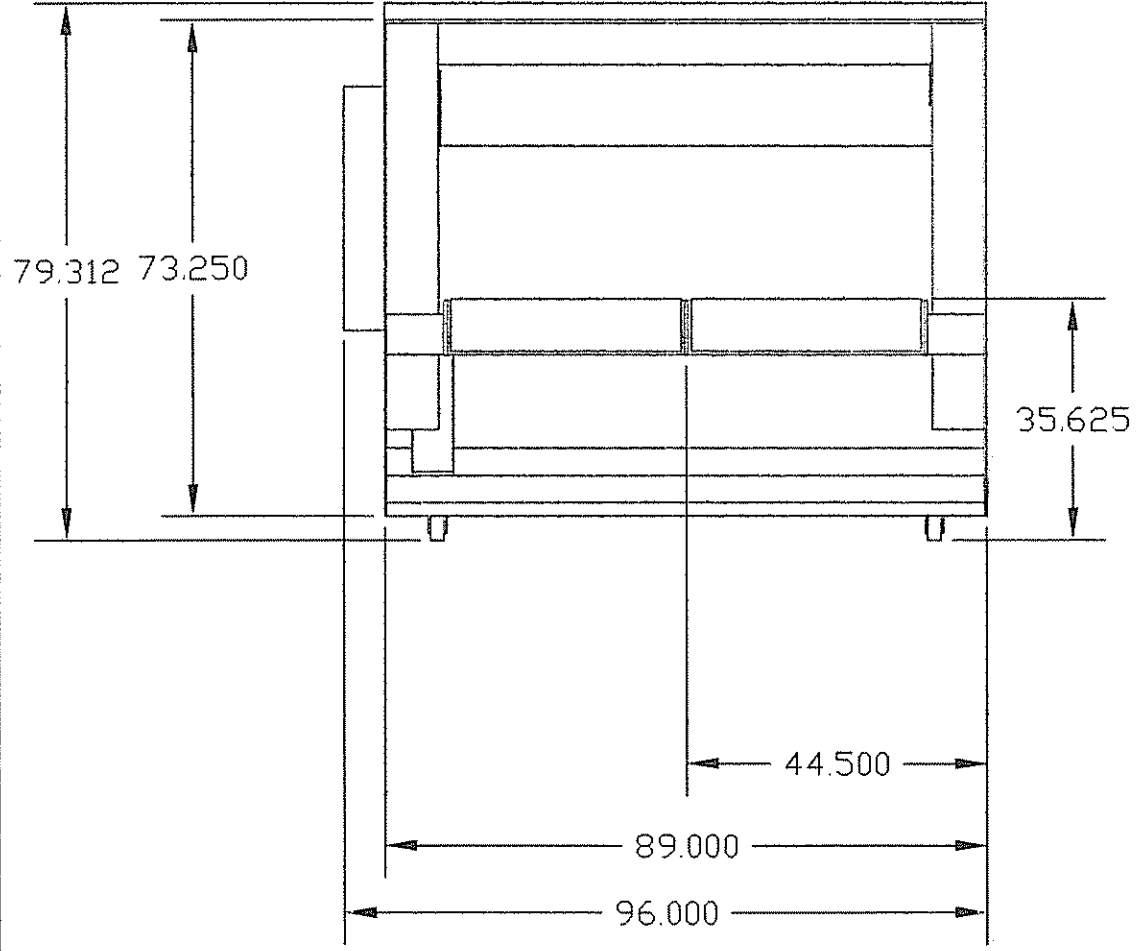
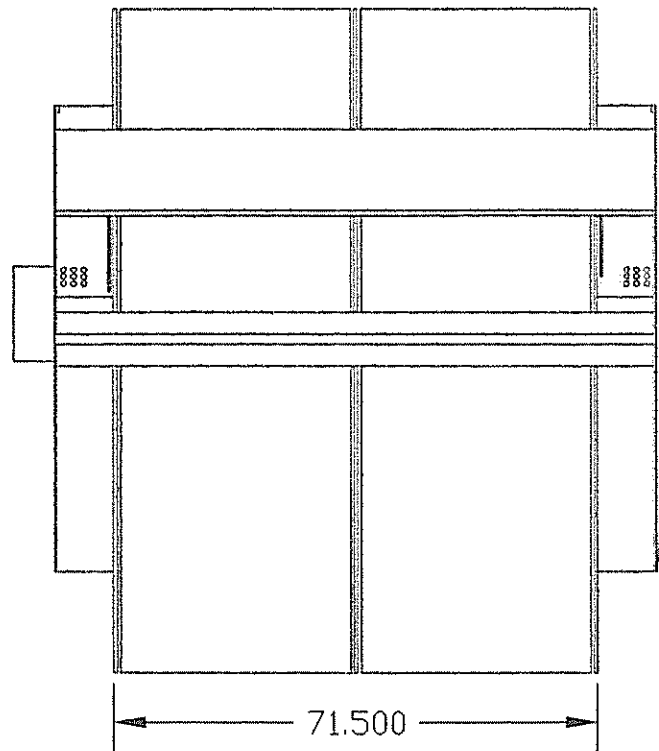

EASTEY ENTERPRISES		Title EB70A BELT IN BELT OUT	
Tolerance ±.010 (UNLESS SPECIFIED)	Scale 1:26	Material N/A	
Drafter TROY S.	Part Numbers EB70A		
CHK By	Date 3-29-07	Part size 0.000 x 0.000	