

INSTALLATION, OPERATION & MAINTENANCE

EasyAir® 8000 Factory Blower Package System

Contents

Machine Warnings	2	Piping Configuration	7
Safety Precautions	3	Maintenance & Lubrication	8-13
Long Term Storage	3	Parts Lists	14
Description	4	Vacuum Package Section	15
Protection Devices & Accessories	5	Wiring Diagram	16
Installation & Start-Up	5-7		



**ROOTS™ products are sold
subject to the
current General Terms of Sale,
GTS-5001 and Warranty Policy
WP-5020. Copies are
available upon request.
Contact your local Roots Office
or Roots Customer
Service Hot Line
1-877-363-ROOT(S) (7668)
or direct 832-590-2305.**

**The blower package,
less blower and consumables
(i.e. lubrication, belts and fil-
ter element), shall come with
a full 18/24 month factory war-
ranty. Reference Dresser Roots
document WP-5020 for the
BLOWER ONLY warranty.**

Machine Warning Signs

Make sure that everyone concerned with operating this machine has fully read and understood this instruction manual, and that they are fully aware of the meanings of the following warning symbols. Some symbols may also be found on relevant parts of the machine.



WARNING! Do not stand on any protruding parts of the unit.



WARNING! Pressurized air can be dangerous. To avoid death or serious personal injury and the risks associated with this type of machine, use safe working procedures. Do not inhale compressed air from the machine, this may also contain gas vapors or solid particles.



WARNING! Ensure machine is fully isolated from mains supply, locked out and the air pressure has been totally relieved before carrying out any maintenance work.



WARNING! Risk of electrical shock. Disconnect from mains supply before removing any covers.



WARNING! Rotating parts. Do not operate without guards in place.



WARNING! Read instruction manual carefully before positioning, operating or making any adjustments.



WARNING! Hot surface. This unit contains surfaces which reach high temperatures during operation.



Ground



WARNING! Risk of accidental start-up. The machine could start automatically in the event of a power cut, reset or when attached as part of an automated system.



WARNING! The unit produces a high sound level during operation. Ear protection should be worn if doors are opened for observation.



WARNING! Pressurized component or system.

Safety Precautions



CAUTION:

The machine is delivered without oil. Oil must be added before starting up, (see page 11).

Follow these precautions in addition to any other local safety regulations when installing, maintaining or operating the machine:

METHODS OF WORKING

- Use proper care and good procedures in handling, lifting, installing, operating and maintaining the equipment.
- Electrical work must only be carried out by suitably qualified and authorized personnel.
- Make sure that the electrical supply is of the specified voltage and has adequate fuse protection.
- Isolate the electrical supply and release all air pressure before attempting to carry out work on the machine.
- The machine is not intended for use as a workstation.
- Oil must be handled, contained and disposed of in a safe and suitable manner.
- Provide adequate safeguards against accidents for persons working on or near the machine during installation and operation.
- Do not direct high-pressure air at any part of the body.
- Do not stack units.

HAZARDS

- The blower casing and associated piping and accessories may become hot enough to cause major skin burns on contact.
- Do not reach into any part of the enclosure or blower when it is operating or liable to accidental starting. Internal and external rotating parts of the blower and its driving equipment can cause serious physical injuries.
- Keep clear of open inlet piping and the discharge of blowers. Before operating the machine with piping disconnected, fit a substantial coarse screen over the open connection.
- Keep clear of the blast from pressure relief valves and unloading valves.

- Avoid extended exposure to machinery that exceeds safe noise levels.
- To prevent unwanted heat and noise emitting from the customer supplied discharge piping it may be necessary to lag or insulate the customer supplied piping.

DO NOT

- Do not attempt to adjust the setting of the pressure relief valve or unloading valve.
- Do not use gasoline or other flammable fluids to clean blower parts.
- Do not exceed the operating limitations specified in the Contract Details without consulting Dresser Roots.
- Do not operate the unit in an explosive atmosphere.
- Do not install the machine close to walls or sources of heat. See page 7 for clearances required.
- Do not bypass or render inoperative any safety or protection devices.
- Do not pressurize vented blower cavities from an external source, nor restrict the vents. The blower casing pressure must not exceed 25 psi (172kPa) gauge.

Other potential safety hazards may also be associated with operation of this machine. All personnel passing through the hazardous area should be warned by signs and trained to exercise adequate precautions.

LONG TERM STORAGE

Providing the long term storage plastic wrap installed around the package before shipping is not disturbed and the package is stored inside a building away from the elements the package can be stored for a period of up to one year with out any requirements.

In the event any of the below concerns arise please consult the factory.

- The package is to be stored outside.
- The package is subjected to high humidity.
- The package is to be subject to extreme high or low ambient temperatures.
- The long term storage protection is removed or damaged
- The package is to be installed for an extended period of time after the long term storage plastic wrap is removed.

Description

GENERAL CONFIGURATION

ROOTS™ EasyAir®8000 blower/exhauster packages are available in a range of sizes, with a general configuration as shown. Each unit consists of an acoustic enclosure containing the blower, blower drive, and accessories mounted on a sub-base assembly.

The acoustic enclosure incorporates removable panels for maintenance access, and is fan-ventilated. Anti-vibration mountings support the sub-base assembly, so that no external anti-vibration measures are required.

The motor drives the blower by means of a V-belt equipped with a unique Roots patented automatic tensioner.

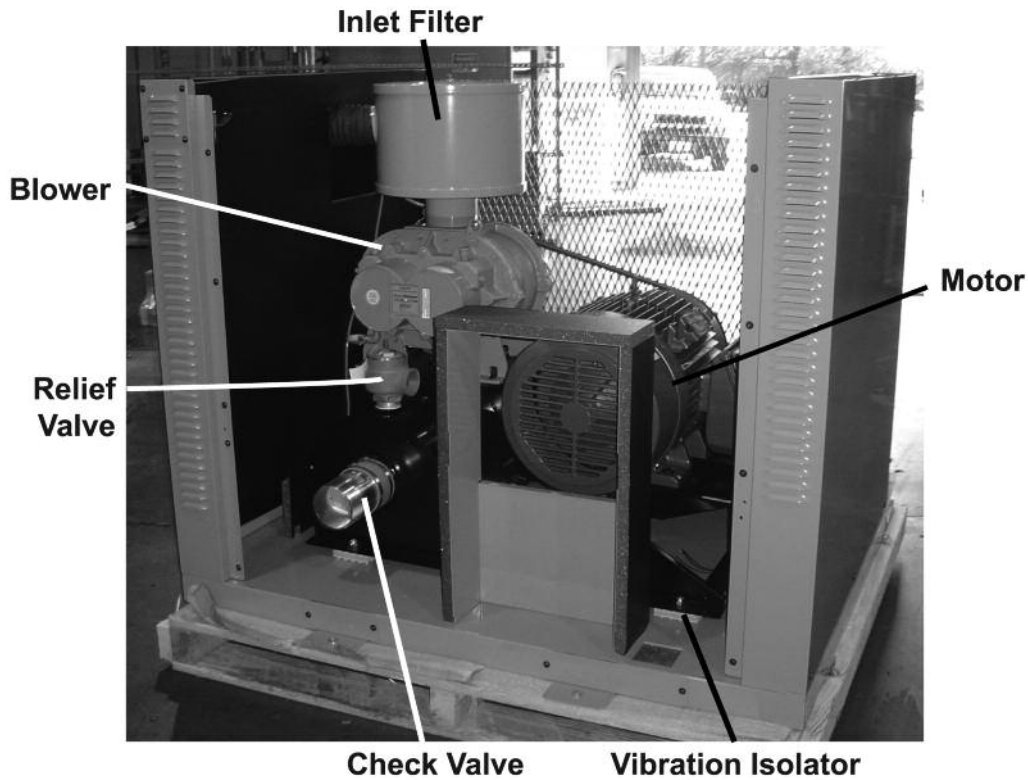

ROOTS Patented Automatic Belt Tensioner

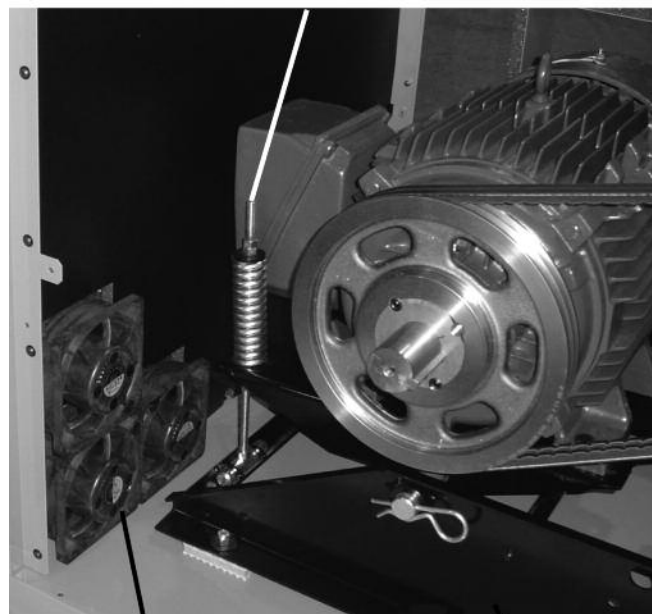

Ventilation Fans

Sub-Base Assembly

Protection Devices & Accessories

STANDARD DEVICES

The following devices are supplied with a standard factory blower package system:

- Inlet filter/silencer
- Panel-mounted filter restriction indicator
- Discharge silencer/sub-base assembly
- Pressure relief valve
- Check valve
- Vibration pad
- Discharge pressure gauge
- Discharge flex connector (before check valve)
- Oil drain manifold
- TEFC EPACT motor
- V-belt drive with patented tensioner
- Acoustic enclosure (fan ventilated)

OPTIONS

These devices can be supplied on request:

- Switches, pressure and temperature
- Unloading valve, Roots patent pending
- Lever-operated butterfly isolation valve, mounted in customer piping down stream
- Starter panel
- Local mount temperature gauge, mounted in customer piping down stream

Installation & Start-Up

LOCATION

Select a location away from walls and obstructions. The front and rear panels are removable, but not the side panels. Allow space for access to the front and rear of the machine as shown. Multiple units can be positioned end-to-end with sufficient gap between them to allow free passage. Do not stack vertically.

If side panel access is expected, use 24" access spacing in place of 1".

FOUNDATION

The unit must be mounted on a firm foundation which must be smooth, flat, and level.

LIFTING AND MOVING

Some units are shipped fully assembled. Others are shipped in two separate sections; the sub-base assembly and the enclosure.

Before attempting to lift or move a unit, refer to the table below for the unit weight and check that this does not exceed the safe working load of the lifting equipment available.

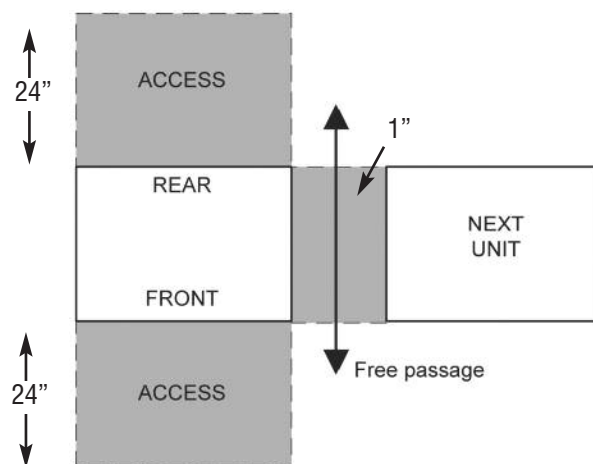

Package with Blower Sizes	Weight (lb)	Weight (kg)
33 & 42	1040	472
45 & 53	1280	581
47, 56 & 65	1900	862
56, 68 & 409	2240	1016
615 & 412	3450	1565
615, 418 & 616	4235	1921

Installation & Start-Up

FULLY-ASSEMBLED UNITS

Remove the screws securing the two cover plates at each side of the base frame assembly and take off the plates to reveal the two channels in the base.

Lift and move by fork-lift truck, or with a hoist using wire ropes and a spreader bar as shown.

ANCHORING

Bolt down the base frame using anchor bolts in the bolt-down holes.

Do not fit external anti-vibration mountings; the machine has integral anti-vibration mountings.

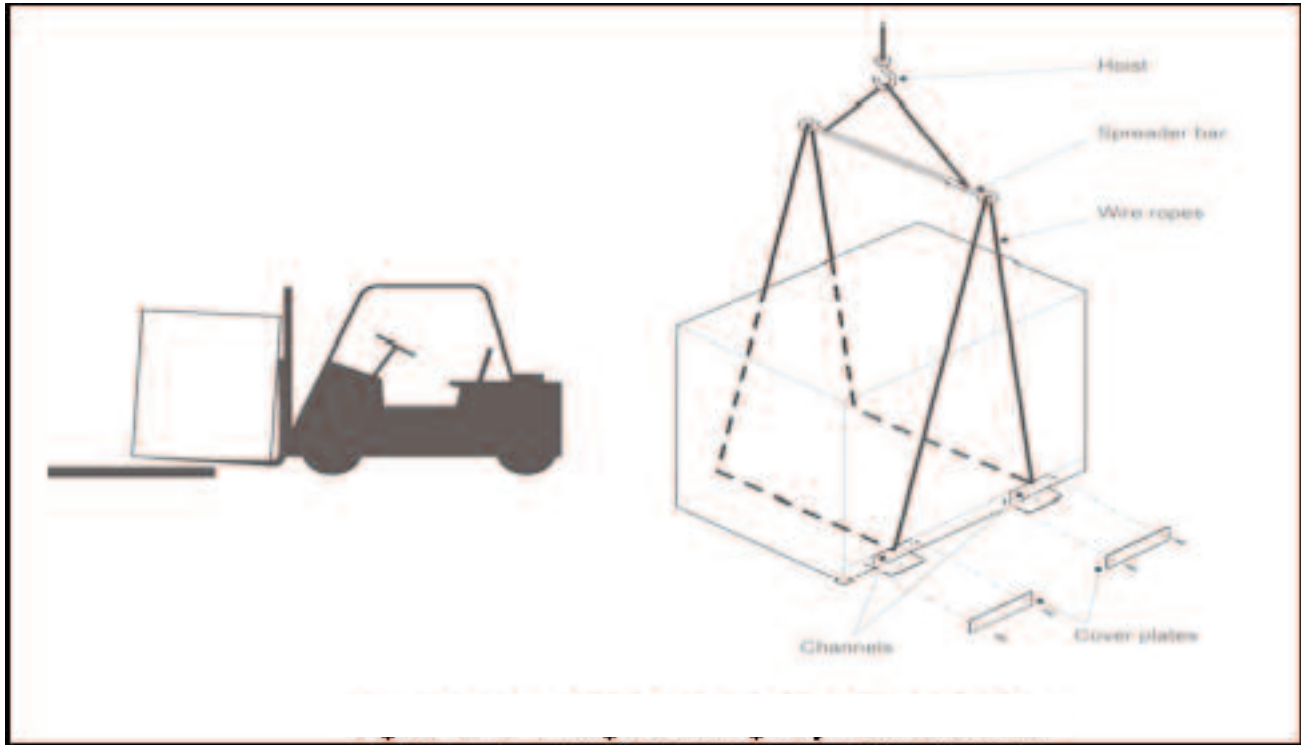

ELECTRICAL



WARNING

Connection and wiring must be carried out by a qualified and authorized person in accordance with local wiring regulations.

Refer to the supplied manufacturer electrical drawings for the main motor, cooling fans and accessories connections.



For large enclosures, cable access opening is provided in lower removable panel.

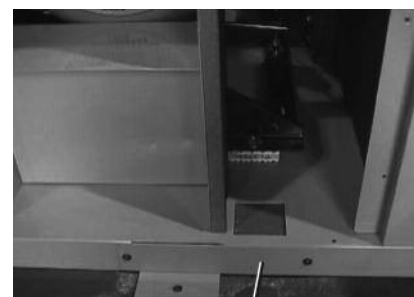

Remove Cover Plate

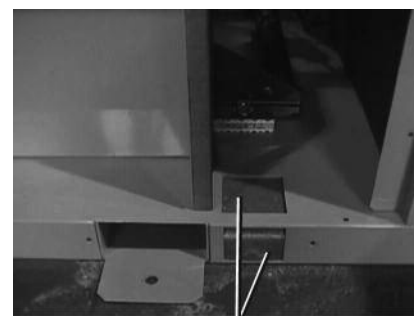

Cable Access Openings

For smaller type enclosures, cable access opening is provided next to lifting tube.

Installation & Start-Up

LUBRICATION



CAUTION

The machine is delivered without oil. Before proceeding, fill the blower with oil of the correct type as detailed in the blower IOM manual. Lubricate motor per manufacturer recommendation.

The specified and recommended lubrication is Roots synthetic lubrication P/N 813-106-XXX of the proper viscosity for the ambient temperature of the space blower and motor are mounted in.

ENCLOSURE TEMPERATURE

Packages are generally supplied with 40°C standard motors. In this case, the temperature inside the enclosure must not exceed 120°F (49°C).

For very hot climates, 50°C motors are needed, in this case, the temperature inside the enclosure must not exceed 135°F (57°C). More frequent oil changes will be required for higher enclosure temperatures.

Start-Up

Carry out the following checks and procedures, and check the boxes to verify that the start-up has been carried out correctly:

Step	Check/Procedure	Done
1	Base frame assembly securely anchored to the foundation. See foundation requirements under the "Installation & Start-Up" section of the appropriate blower package manual.	<input type="checkbox"/>
2	Machine filled with the specified and recommended Roots synthetic lubrication of the proper viscosity for the ambient temperature of the space the blower and motor are located. Detailed instructions regarding filling the blower with lubrication and installing the decals attached to the lubrication sight tubes are provided on page 9 of this manual. Please refer to these instructions for proper filling and decal installation instructions. DO NOT OVERFILL	<input type="checkbox"/>
3	Piping and check valve connected w/ flexible connection installed. Flexible connections w/ control rods require proper adjustment. Please refer to the appropriate blower package manual for installation procedures.	<input type="checkbox"/>
4	Drive belt alignment and tension are correct. See "Drive belt" section of the appropriate blower package manual.	<input type="checkbox"/>
5	Correct direction of rotation is CCW when facing the shaft end of the blower. (Jog motor – check direction corresponds with direction shown by the direction arrows) Wait for the blower to come to complete stop before restarting (jogging) the motor.	<input type="checkbox"/>
6	Run machine for 1-1/2 hours. Check for leaks, vibration, hot spots or unusual noises.	<input type="checkbox"/>
7	Re-check drive belt tension to verify correct after first 8 hours of operation.	<input type="checkbox"/>
8	Verify relief valve operation.	<input type="checkbox"/>
9	Verify all exhaust fans are operating when main motor is operating.	<input type="checkbox"/>
10	If the package was supplied with shut down/alarm instrumentation verify if shut down/alarm instrumentation is installed and operating.	<input type="checkbox"/>
11	If the package was supplied with a 0" to 60" H2O filter indicator gauge refer to the "filter" comments under "Maintenance & Lubrication" section and mark the filter indicator gauge accordingly.	<input type="checkbox"/>

Piping Configuration

Customer Piping Connection: Customer piping discharge/inlet should be connected to the package in a manner that will not exert external forces on the package. A flexible expansion joint should be used between package and the customer connection.

In the event the package was supplied with a metal bellows type discharge expansion joint please refer to the instructions below for proper installation and adjustment.

INSTALLATION OF CONTROL RODS FOR METAL BELLOWS TYPE EXPANSION JOINTS:

To prevent over extension of the bellows, nuts "A" and "E" are welded to the control rods.

To prevent over compression of the bellows, locate nut "D" 0.50" from the lug "F". Jam nut "C" against nut "D" to prevent its movement during operation.

There are four control rods "E" per expansion joint.

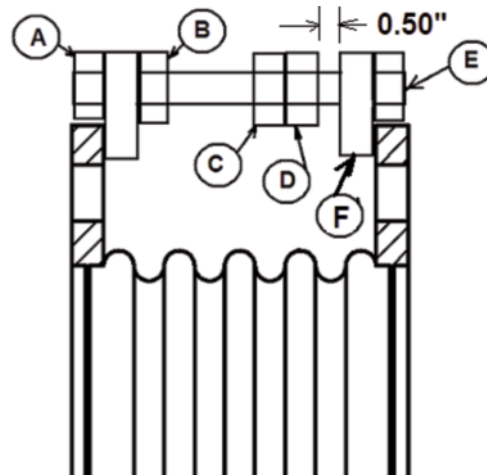

Maintenance & Lubrication

ACCESS



CAUTION

If machine is observed through guard while in operation, all relevant Health and Safety Steps and Precautions must be adhered to!



Hearing protection must be worn for running visual inspection!



1. Use screwdriver to unlock panel by turning 180°.



2. Remove panel.



3. Use a 5/32" allen wrench to remove screw holding guard screen.

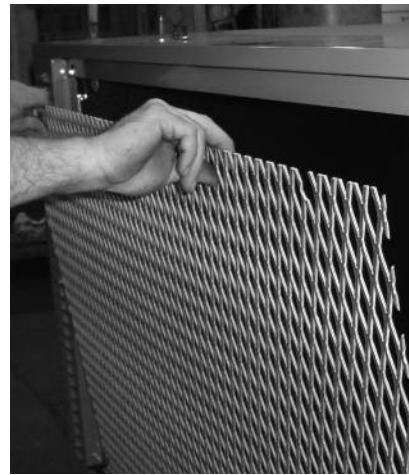

4. Remove guard.

- For general routine maintenance of the unit, such as oil top-off/change, belt tension check, etc., the guards located behind the upper doors are easily removed by using a screwdriver.
- Ensure guard is supported while the screws are removed.
- For major maintenance, the roof, side walls and lower panels can be also removed giving easy and unrestricted access from both sides and above.



5. Loosen toggle clamps holding roof.



6. Lift the roof off.



7. To remove side panels, remove screws on the outside (3 to 4 depending on size).

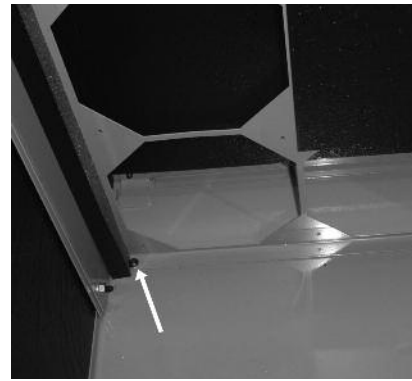

8. Remove (3 to 4) screws holding side panels on the inside. Lift panels off the enclosure base. (Fan removal required).

ROUTINE MAINTENANCE SCHEDULE

Frequency	Item	Action	Reference
Weekly	Filter	Refer to the filter section for pressure units and the vacuum section for vacuum unit inlet filter service intervals.	Filter, page 10
Monthly	Drive	Check condition of belts. Verify tension.	Drive belt, pg. 13
Weekly	Lubrication	Check lubricant level and top off if necessary.	See blower manual
As required	Lubrication	Refer to the specific blower manual "Lubrication section" supplied with the package for information regarding determining lubrication service intervals based on the discharge air temperature. Maximum lubrication service life of the <i>specified and recommended</i> Roots synthetic lubrication should be considered 6000 hours.	See blower manual
Monthly	Ventilation	Check condition and operation of ventilation fan. Clean fan.	

*Check/change may be required depending on operating oil temperature. Refer to blower manual.



For maintenance of the motor, refer to the manufacturer's manual.

Due to sludge build-up and seal leakage problems, Roots recommendation is DO NOT USE Mobil SHC synthetic lubricants in ROOTS blowers.

During the initial start-up the below instructions must be followed.

Lubrication Decal installation procedure.

Please follow the below steps before installing the supplied lubrication decal(s).

- Using the table below select the appropriate blower frame size supplied in the package. The blower frame size can be found on the serial tag located on the gearbox or opposite end of the drive on the blower itself.

These capacities above are provided to assist with the lubrication filling process of EAX2 packages. Exact sump capacity may differ slightly depending somewhat on the level of the package.

EasyAir® X2 Approximate Oil Sump Capacities

Blower frame size	Gearbox		Drive End	
	Fl. OZ.	(Liters)	Fl. OZ.	(Liters)
155, 225, 280	42	1.24	25	0.74
400, 500	101	2.98	56	1.66
600, 770	161	4.76	76	2.25
800, 1000	263	7.8	127	3.76

Note: the blower/silencer base must be level with in 1/16" each direction.

- Using the lubrication sump capacities provided above measure the called out amount of the specified and recommended Roots synthetic lubrication and pour these amounts into each respective drive end and gear end lubrication sump.
- Allow sufficient time for the lubrication to level out in the lubrication sumps.
- Allow sufficient time for the lubrication to make its way through the hoses and into the lubrication sight tube mounted on the front of the cabinet.
- After a period of time verify the lubrication level in the two sight glasses on the blower itself. The lubrication level in the sight glasses on the blower should be within .060" of the center line of the sight glasses. The two sight glasses are located on the left side (motor side) of the blower when facing the drive end of the blower.
- Adjust each lubrication sump until the lubrication level in both sight glasses on the blower is with in .060" of the

center line of the sight glasses. **DO NOT OVERFILL.**

7. After sufficient time has transpired for the lubrication to make its way through the hoses and into the lubrication sight tube mounted on the front of the cabinet note the lubrication level in the sight tube.
8. Remove the decal backing exposing the self adhesive surface and apply it to the lubrication sight tube with the bottom of the top red line at the top of the lubrication level in the sight tube.
9. The lubrication level must be maintained between the two red lines on the decal when the blower is not operating.



WARNING

Top off the oil when the machine is stopped; never while it is running.

The level should be between the indicator lines when the unit is not operating as shown below.

To top off, lift the hinged filler cap, add oil until the level is correct, and close the filler cap. **Do not over-fill.**

DRAINING AND FILLING

To drain the oil:

1. Stop the machine and disconnect the power supply.
2. Remove the upper door panel from the front of the enclosure.
3. Place a suitable container beneath the drain tap(s).
4. Remove breathers from blower covers and loosen and remove drain plugs in front of oil level gauges.

To refill:

1. Close and tighten the drain plugs.
2. Add oil through the breather holes in blower covers until the level is between the lines marked on the decal. Again, the unit must be filled when the unit is not operating. Never over-fill.

4. Replace the breathers.
5. Clean up any spilled oil for safety.
6. Replace the door on the enclosure.



Lubrication

FILTER

If the package was supplied with a filter indicator gauge that reads 0"-60" H₂O vacuum use these instructions to determine when the inlet filter element should be serviced.

At start-up of the package and under normal loaded conditions note the base reading vacuum level on the filter gauge with the clean new filter element installed. The filter must be cleaned or renewed at 10"-15" H₂O above the base reading.

It is recommended that the filter indicator gauge be marked at 10" H₂O and 15" H₂O above the base reading. The filter element must be cleaned or renewed when the reading is between these two marks.

If the package was supplied with a filter indicator gauge that reads in green, yellow and red, follow the instructions on the face of the filter indicator gauge

Never allow the package to operate with a restricted inlet filter.

REPLACING THE FILTER



We recommend that you keep two or more spare filter elements and replace them as indicted in the Routine Maintenance Schedule.

When replacing always use genuine Dresser parts.

CHANGING THE FILTER



CAUTION

Machine must be switched off, fully isolated and stationary before attempting to clean or change the filter element!

- Unscrew filter lid depending on type. (See following pictures).
- Break seal and lift lid off.
- Remove filter element.
- Inspect.
- Refit or replace element.
- Refit lid and fasten in position.

Changing inlet filter with 6 & 8" flange connection.



1. Remove four wing nuts holding side panel

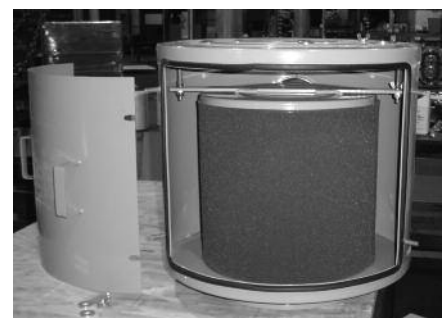

2. Remove side panel

Maintenance & Lubrication



3. Loosen wing nuts, move them up about one inch.

Changing inlet filter with 4 & 5" NPT connection.



1. Remove filter lid wing nut.



4. Remove filter cap and remove filter.



4. Lift lid off.



2. Lift lid off.



1. Remove filter lid wing nut.



2. Remove lid and remove filter.



5. Slide lid out & remove filter.



3. Remove filter cap wing nut.

DRIVE BELT



CAUTION

When rotating pulleys by hand, beware of finger entrapment between belt(s) and pulleys!



Always ensure when replacing any parts of the drive that identical replacements are always used.

The use of non compatible replacements can result in severe damage of the machine!

Maintenance & Lubrication



Belt Tension Indicator

The automatic tensioner maintains the correct V-belt tension under normal working conditions, but it is good practice to check that the tensioner is performing correctly as indicated in the Routine Maintenance Schedule.

For checking belt tension, you may use Dodge V-belt tension tester part # 109082. Original instructions can be obtained from: www.dodge-pt.com/pdf/instruct_manuals/499429_499799/499515.pdf



CAUTION

Drive alignment is factory set but may move during transportation, it is therefore good practice to check the drive alignment on initial installation!

Occasions when the following procedures will be required are when either the motor or blower has been fully removed for overhaul!

In the event of the drive needing realignment use the following procedure:

- Secure Blower in position.
- Leave motor bolts finger tight.
- Ensure there is NO tension applied by the self-tensioner (fully released).
- Using a straight edge pushed hard against the blower pulley face with right hand. Allow the left hand to drop down towards the motor pulley. Check position of motor pulley face against straight edge.
- Reposition motor as necessary to ensure straight alignment of both pulleys.
- Carefully re-tighten motor bolts fully and re check alignment.
- Refit belt(s).
- Spin the pulleys 3 to 4 revolutions to bed belts into the pulley grooves.
- Tension belts per manufacturer recommendations.



Procedure describing the removal and replacement of drive belts.

Removal:

- On top of the tension spring and on the threaded rod is two nuts locked together. Using two wrenches break the two nuts loose.
- Loosen the top nut approximately two inches. Then loosen the second nut and this will begin to loosen the tension on the spring and allow the belt tension to be released.
- The nuts must be loosened enough to allow the belts to be removed with out having to force the belts over the rim of the pulleys. Remove the belts.

Replacement:

- Using genuine Dresser belts install the belts over the motor and blower pulleys. The belts must not require force to install them over the pulleys.
- Once the belts are installed on the pulleys begin to tighten the bottom nut on the tension device until the belts begin to become snug.
- Spin the pulleys 3 to 4 revolutions to bed belts into the pulley grooves.
- Continue to tension the belts with the lower nut while spinning the pulleys to insure the belts are bedded in the pulleys.
- During tensioning the belts an automatic belt tension indicator must be used to properly tension the belts. The belt tension indicator as shown on this page comes with detailed instruction regard proper tension of the belts.

Note: In order to properly tension banded belts follow the instructions on the bottom of the information provided with the tension tester marked "Polyband belts".

- Once the belts are tensioned to the proper tension the top nut should be tightened down against the lower nut to insure they do not come loose.
- Even though the package has a belt tensioning device the belts tend to stretch in the first 24 hours of operation more than the tension device is designed to accommodate. Therefore after the first 24 hours of operation the belt tension should be verified and adjusted if required.



Drive Belt Tension

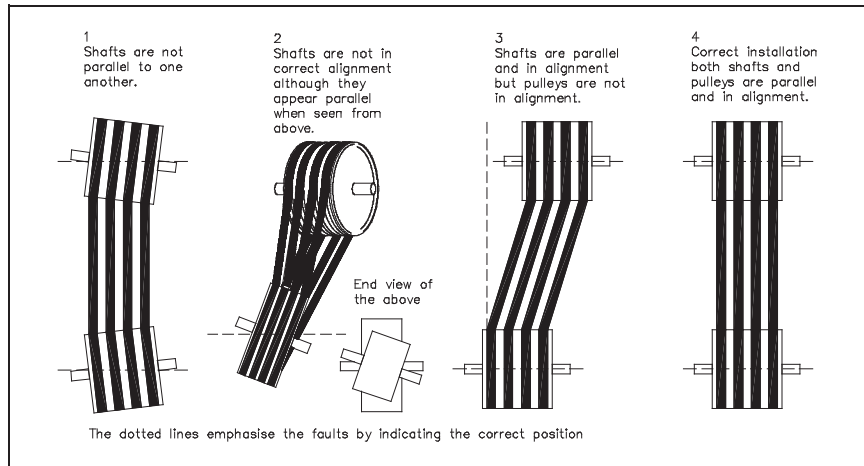

PRESSURE RELIEF VALVE



CAUTION

Never attempt to readjust the valve setting(s). If there is a problem consult with a member of Dresser ROOTS Aftermarket/Service team.

This machine is fitted with a factory-set pressure relief valve. This device is to prevent over pressurizing of the blower, silencer and other parts of the system.

The valve will open whenever the system pressure reaches the relief valve setting; this is an indication that there is something wrong in the downstream pipe work.

If the valve opens, shut down the system immediately and determine the cause of obstruction in the discharge pipe work. Do not simply try to stop this by readjusting the valve settings.

Possible causes: closed isolation valve, build up of material in the system pipe work or some other type of obstruction.



CAUTION

Do not operate blower for extended period with relief valve open, this will cause the enclosure temperature to rise suddenly and damage the equipment inside.

Parts Lists

ENCLOSURE

Item	Description
1	Upper Door Panel
2	Lower Door Panel - Front Side
3	Upper Door Panel - Discharge Side
4	End Wall Assembly - Fan Exhaust
5	End Wall Assembly - Inlet
8	Roof
9	Cable Entry
10	Lower Panel/Discharge Cover Plate
11	Fork Tube Cover Plate
12	Base

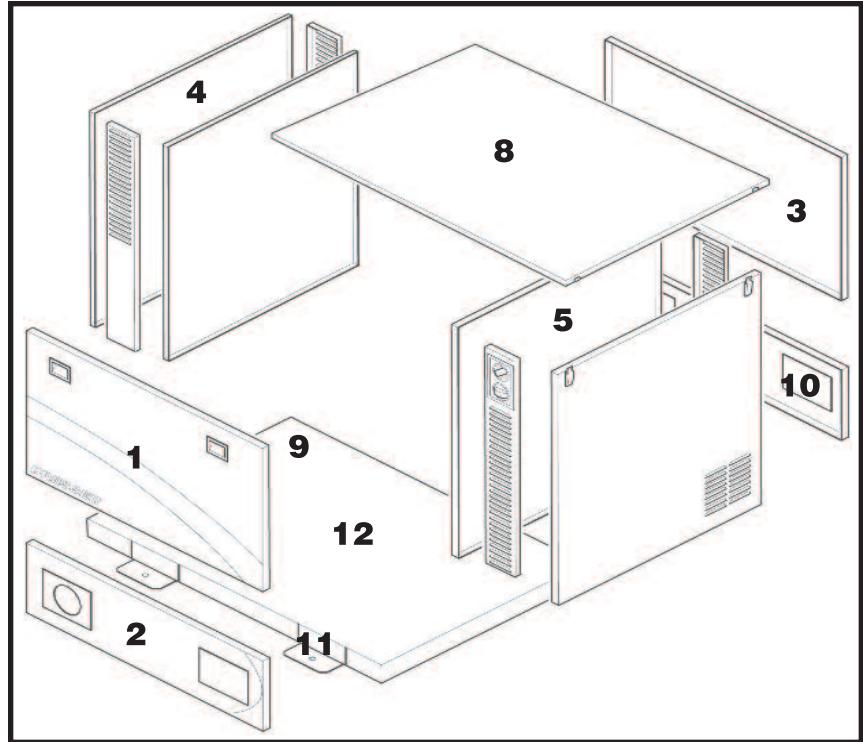

BLOWER ASSEMBLY

Item	Description
1	Compact Inlet Filter Silencer
2	Blower
3	Drive
4	Motor
5	Self-Tensioning Assembly
6	Ventilation Fan
7	Anti-Vibration Mounting
8	Discharge Silencer Base

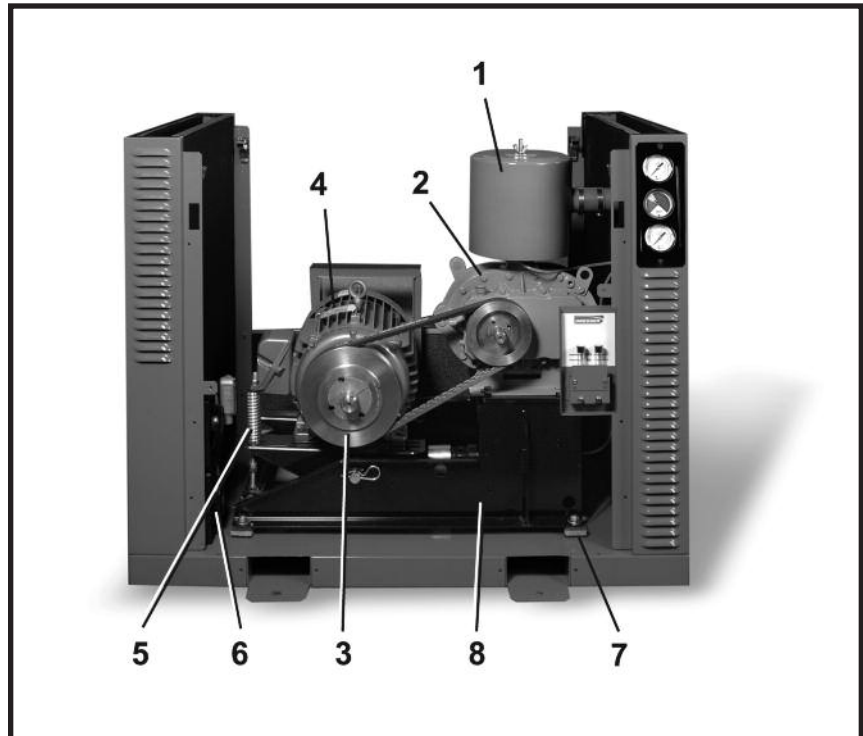

Vacuum Package Section

Filter

Follow these instructions to determine when the inlet filter element should be serviced. At start-up of the package and under normal loaded conditions note the base reading vacuum level on the filter gauge with the clean new filter element installed. The filter must be cleaned or renewed at 10"-15" H₂O above the base reading. It is recommended that the filter indicator gauge be marked at 10" H₂O and 15" H₂O above the base reading. The filter element must be cleaned or renewed when the reading is between these two marks. Never allow the package to operate with a restricted inlet filter.

Please refer to the Maintenance & Lubrication section of this manual for additional warnings and filter replacement instructions.

Warning

Air blast and noise from discharge of vacuum packages must be treated to prevent injury or excessive noise.

Discharge air from vacuum packages can be piped away from the package. Please consult Roots regarding treating the air blast.

