

A-Series GP



Flexible printing capabilities up to 5 lines



IP55 stainless steel cabinet for a wide range of environments



Wide range of general purpose inks

The A-Series GP: Value without compromise

The new A-Series GP has its roots in the proven Domino A-Series platform, the world's best-selling Continuous Ink Jet (CIJ) printer. The A-Series GP retains all of the strengths and value that the market has come to expect from a Domino CIJ printer, but without some of the cost. The GP printer has been designed and built to provide a solution for where solid dependable basic performance is a necessity, but high end functions are less important.

Two new members of the A-Series family that share common Domino values:

RELIABILITY

- Patented sealed nozzle printhead and true autoflush ensure reliable start-ups, even after extended periods of shut down
- Large volume reservoir based ink system ensures stable, predictable performance in any application
- Sealed cartridge fluid replenishment for clean operation
- New high tech inks engineered for extended life - optimised for reliability and performance

FLEXIBILITY

- IP55 cabinet for reliability in any environment
- Compact rugged stainless steel cabinet
- All available rasters and print formats on board allowing the machine to be configured from the user interface
- Multi-language User Interface (UI)

SIMPLICITY

- Ease of installation
- Domino Sure Start auto flush – the industry benchmark for start / stop performance
- Intuitive user interface – drag and drop fields
- No mess, no mistake sealed ink system

A100GP – SIMPLICITY AND VALUE

- 60 Micron nozzle size
- 3m conduit
- Up to three lines of print with single and mixed line capability (25 drop)
- Low to moderate production speeds (Standard Rasters)
- Optimised, high performance ink, for a wide range of applications and substrates

A150GP – PERFORMANCE AND VALUE

- Print up to five lines (31 drop)
- 60 Micron nozzle size for speed and quality
- High production speeds – up to 325m/min
- Machine readable codes – common barcode formats and data matrix codes
- General purpose ink range and choice of solvent bases
- Simple connectivity options with Ethernet
- Webserver and printer control



TECHNICAL SPECIFICATIONS

A-SERIES GP

All dimensions in mm (inches).

CONTROL UNIT		
CONTROL PANEL	Membrane button	
Cabinet:	304 or equivalent Stainless steel	
Cabinet dimensions:	244x468x650mm (DxWxH)	
Weight:	23kg	
INK SYSTEM		
Viscosity control:	Automatic	
Autoflush head cleaning:	Standard	
Ink and make-up refill:	825ml cartridges	
Ink reservoir life:	2000 hours (ink dependent)	
PRINT HEAD		
Nozzle sealing	Standard	
Conduit length:	3m	
Conduit connection at cabinet:	90°	
ENVIRONMENT		
IP rating:	IP55 1992	
Temperature range:	5-45°C	
Humidity:	10 - 90% non condensing	
Electrical requirements:	100-250V, 47-63Hz	
STANDARD CONNECTIONS		
Product detector:	NPN/PNP	
Shaft encoder input:	NPN/PNP	
OPTIONS		
	A100 GP	A150 GP
Alarm beacon connector:	Option	Option
Auxiliary alarms connector:	Option	Option
Peltier:	NA	Option
Positive air:	Option	Option
User port connector:	NA	Option
90° Printhead:	NA	Option
90° elbow at head:	NA	Option
V90° Printhead:	NA	Option
ACCESSORIES		

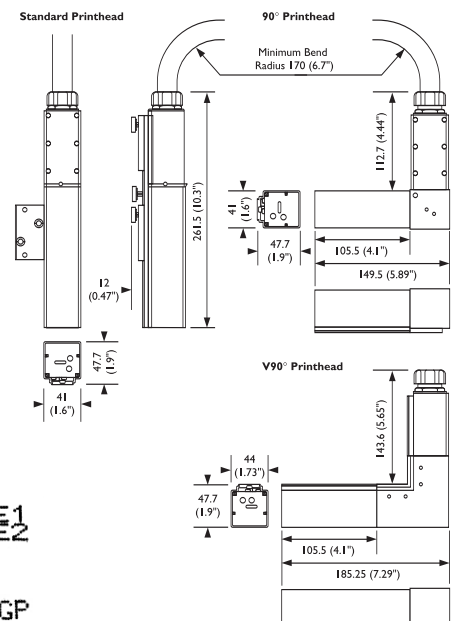
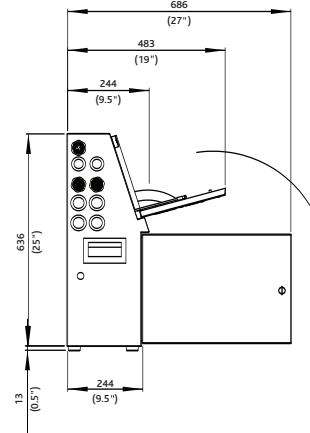
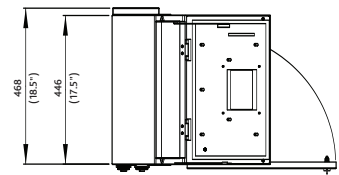

CANADA
 Domino Printing
 Solutions Inc.
 2751 Coventry Road
 Oakville
 Ontario
 L6H 5V9
 Tel: + 1 800 387 7972

INDIA
 Domino Printech India
 Private Limited
 167, Udyog Vihar Phase I,
 H.S.I.D.C Gurgaon -
 122016 Haryana
 Tel: + 91 124 400 7406

UNITED ARAB EMIRATES
 Domino UK Ltd.
 P.O. Box 16984
 Jebel Ali Free Zone
 Dubai
 U.A.E.
 Tel: + 971 4 88 35003

UNITED KINGDOM
 Domino UK Ltd.
 Bar Hill
 Cambridge
 CB23 8TU
 Tel: + 44 1954 782 551

UNITED STATES
 OF AMERICA
 Domino Amjet, Inc.
 1290 Lakeside Drive
 Gurnee
 Illinois 60031
 Tel: + 1 800 486 7414



www.domino-printing.com

