

Packaging - Processing
Bid on Equipment
1-847-683-7720
www.bid-on-equipment.com

Doboy Inc.

869 South Knowles Avenue
New Richmond, WI 54017 USA
Phone (715) 246-6511
Fax (715) 246-6539
sales@doboy.com
www.doboy.com

Bosch Packaging Technology

Printed in U.S.A.

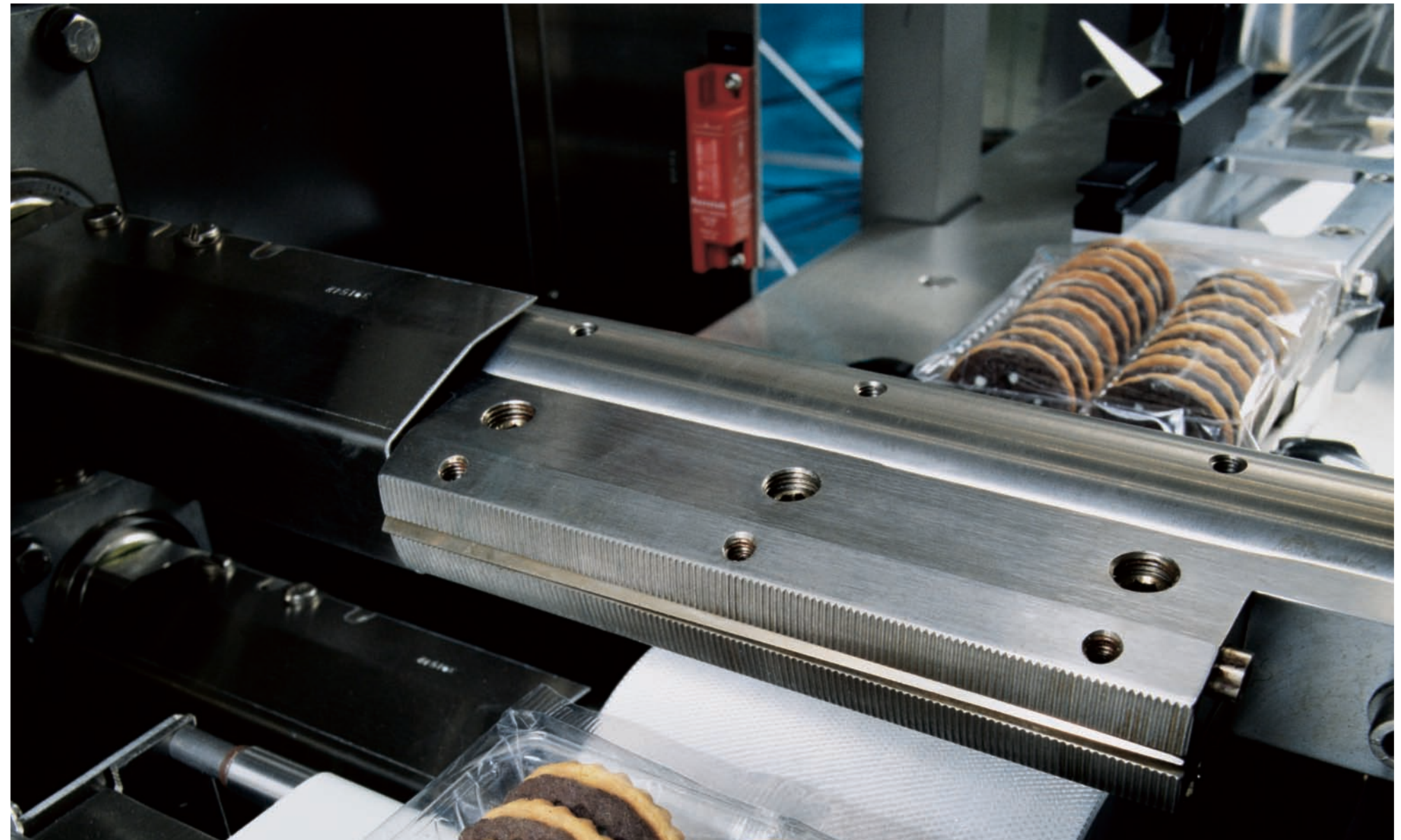

Stratus™ Horizontal Wrapper
Economic Pillow-Pack Packaging of Food
and Non-Food Products

Doboy



BOSCH
Invented for life



Protective, Appealing and Economical Packaging

Easy Operation

This low-cost electronic horizontal wrapping machine comes with electronic controls that offer fast and precise product changeover capabilities equivalent to machines three to four times the price. Installation and start-up of the Stratus takes just two hours! And its compact design offers production layout flexibility.

The Stratus is perfect for a wide variety of products from hardware, bakery, candy, housewares and many other industries.

Package Quality

Quality package seals, tightness and appearance are easily achieved with two sets of finwheels in conjunction with the inclination roller. A "no-tool-required" handwheel for centering the end seal adds the final touch. Three independent servo motors for driving the infeed chain, film feed and end seal crimpers assure consistent control of product, package material and sealing. Also, the Stratus design eliminates drive chains, belts and variators. The result is less maintenance, less wear and greater consistency in machine operation and package quality.



The machinery shown herein may have had guards removed for illustrative purposes. NEVER operate this machinery without all guards in place and all safety features in original working condition.

Features

- ▶ Twenty pre-programmable product setups.
- ▶ Film jog aids in making film changeovers.
- ▶ Infeed conveyor with stainless steel product guides provides ample room for hand feeding and meets FDA sanitation requirements.
- ▶ Compact design for easy maneuvering into smaller production areas.
- ▶ Torque sensitive servo motors stop the machine if jams occur in the infeed or end crimpers.
- ▶ Precise heat controls with digital setpoints and out-of-range alarms assure consistent seal quality.
- ▶ Optional Electronic Two-way Eye Correction precisely positions printed film on the package and minimizes film waste created during setup.
- ▶ Two sets of finwheels.
- ▶ Full range of adjustable formers.



Easy to understand control panel improves operation efficiency with features such as on-the-fly product centering and optional printed film positioning.



Package Specifications

	Length	Width	Max. Height
Single Crimp 120 mm diameter (standard)	4" - 14 3/4" (100 mm - 370 mm)	1/2" - 8 1/4" (13 mm - 209 mm)	2 1/2" (63 mm)
Single crimper 150 mm diameter	4" - 18" (100 mm - 460 mm)	1/2" - 8 1/4" (13 mm - 209 mm)	3 3/4" (95 mm)
Two-up crimper 120 mm diameter	3" - 7 1/4" (75 mm - 185 mm)	1/2" - 8 1/4" (13 mm - 209 mm)	2 1/4" (57 mm)
Two-up crimper 150 mm diameter	3" - 9" (75 mm - 230 mm)	1/2" - 8 1/4" (13 mm - 209 mm)	3 1/2" (85 mm)

NOTE: Optional Wide sealing jaws available - 9" (230 mm) wide crimper

Technical Data

Machine Weight 900 lbs. (410 kg)
 Power 220VAC, 50/60Hz, 1 phase NEMA 1
 Web Specifications Max. Width 18 1/2" (470 mm)
 Max. Diameter 16" (400 mm)
 Core Diameter 3" (75 mm)
 Production speed 20 to 150 packages per minute
 (with a two-up crimper arrangement)

Specifications subject to change without notice.

Detailed View

A detailed view of product packaging by a Dobby Stratus Wrapper

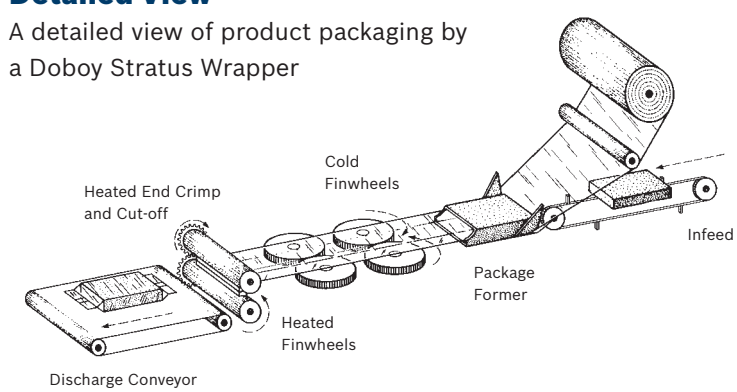

Available Options

- ▶ Configuration for larger products
- ▶ Date/product identification coder
- ▶ Hole punch crimpers
- ▶ Zig-zag knife
- ▶ Two-up crimpers
- ▶ No product - no paper
- ▶ Stainless steel construction

Stratus Mechanical Dimensions

