



Dixie Canner Company

786 East Broad Street, Athens, Georgia 30601 USA
706-549-1914 706-549-0137 FAX
sales@dixiecanner.com • www.dixiecanner.com

Worldwide Dependability — Can Packaging & Processing Equipment

OPERATOR'S MANUAL Model 23 or 24 Belt Drive Electric Seamer



Model 23-500 (shown)

If you are not experienced with your seamer, please read and understand this manual before operating the machine. If you have a question discuss it with your supervisor or contact Dixie Canner Company.

INTRODUCTION

Dixie Model 23 and Model 24 Seamer are adaptable for closing round, rigid containers with lightweight metal ends from 200 to 404 diameters (2" to 4¼" diameters) and up to five inches tall. At time of fabrication, the Model 24 may be fabricated with extension posts to accommodate containers taller than five inches.

Model 23 Seamers are equipped with die cast bevel gears and are recommended for closing cans with a filled weight of less than two pounds. The maximum can height for a Model 23 Seamer is five inches.

Model 24 Seamers are equipped with one steel bevel gear and one bronze bevel gear, and a drive shaft with a keyway. Model 24 Seamers may close cans with filled weights of more than two pounds and which may exceed five inches in height.

Following the model number of either seamer are digits to indicate the height of the extension posts used in the seamer (i.e., the tallest can height the seamer may accept). Machines built to handle cans taller than five inches will also have the same digits on the frame extension posts.

Instructions for operating, adjusting, changing, timing, etc., outlined in this manual are referenced to the seamer mounted on a table or counter top. Drawings and sectional views are shown within this manual to illustrate specific details.

The can revolves only during the seaming cycle. Both seaming rolls automatically operate by a seaming cam to assure a perfect seam when properly adjusted.

Seam rolls are full floating and interlock with the chuck in such a manner as to remain in perfect alignment and eliminate damage to the rolls or chuck through faulty adjustment.

The seamer was equipped with seaming rolls, chuck and base plate to close a specific can size. Unless otherwise specified, the motor was shipped with a 115 volt AC motor, 1/3 HP, 1725 RPM. A special chuck wrench for installing or removing chucks and a set of gauge wire for setting initial seam adjustments were included with your seamer. Refer to Parts List pages for optional equipment or accessories that may have been ordered with this seamer which may include change parts for different can sizes, tools and spare parts.

INSTALLATION

Unpack the seamer base and attach seamer securely to table or bench.

1. Install the motor and V-belt drive.
2. Install the belt guard.

When electrical current is supplied to the seamer, the large driven pulley turns counterclockwise (with the operator facing the seamer), and cam roll levers are in neutral position. When the start lever is moved quickly to the left and then released, the clutch cam is engaged with the driving pin which causes the chuck to turn the correct number of times to seam a can. The chuck will stop automatically with both cam roll levers in neutral position.

OPERATION

1. Raise can lever [23] to horizontal position which lowers the base plate.
2. Place top on the can to be closed and set can on the base plate. Press can lever [23] downward thus raising the can and clamping the top (lid) tightly against the chuck.
3. Move the starting lever [73] to the left until the starting latch [60] engages against the tip of the cam housing [8]. The can will be sealed automatically then stop turning.
4. Raise the can lever and remove the can.

CHANGING FROM ONE SIZE CAN TO ANOTHER

Change parts consisting of a chuck, a base plate and a height spacer may be required for each different can diameter, top or style. Also, a different set of seaming rolls may be required for each. Your can manufacturer or supplier may recommend the seam roll profiles for your cans. Dixie stocks or may be able to furnish the seam roll profile needed. Make sure you have the correct change parts available when changing your machine from one can size to another, then proceed as follows:

1. Turn driven pulley [78] until seam rolls assume their neutral position.
2. Loosen lock nuts [16] and loosen set screws [17] until seam roll levers [12] are back as far as they will go.
3. Remove tension spring [64] and housing cover [1] to expose the upper end of the chuck shaft [14-1].

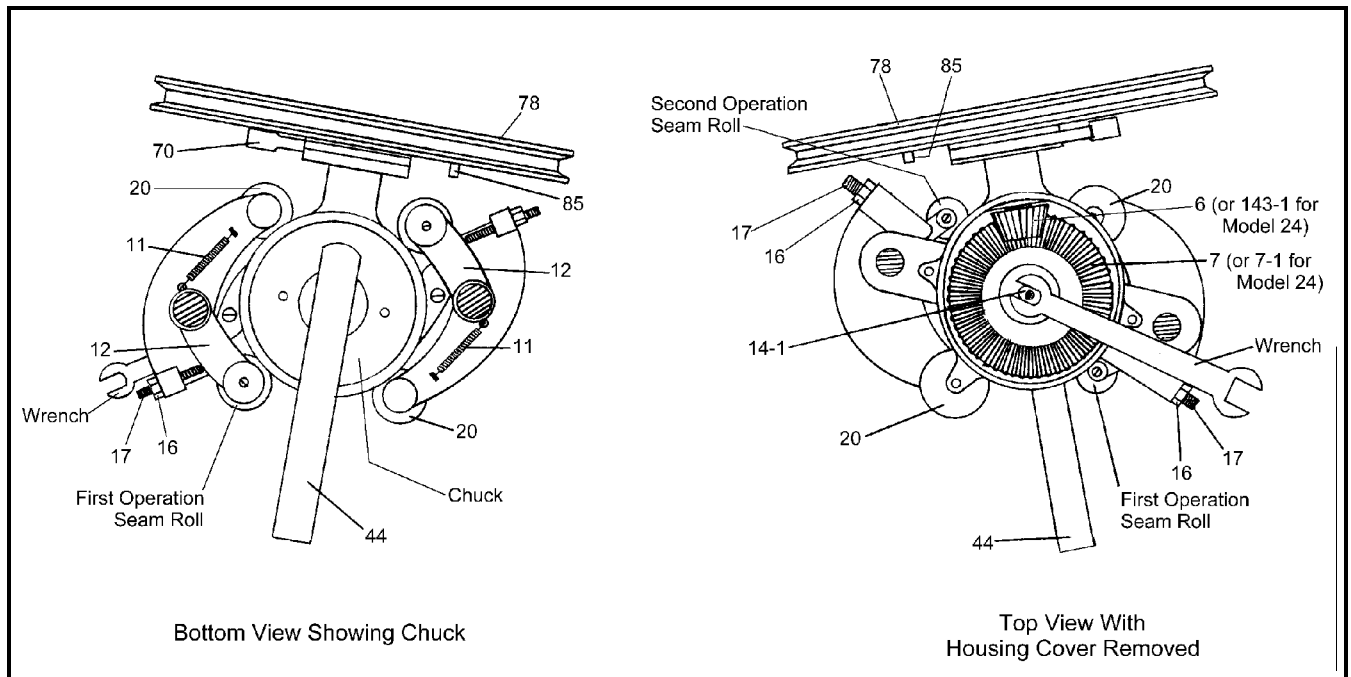

4. Change chucks. **CAUTION:** To prevent damage to the chuck shaft and/or internal gears, use an open end wrench to hold the chuck shaft while loosening or tightening the chuck.

To remove the chuck, hold the chuck shaft [14-1] with a wrench on the top of the shaft, located under the gear housing cover. Then place the two pins of the chuck wrench [44], provided with your seamer, into two of the four holes located on the bottom of the chuck. (The pins of the chuck wrench will fit into either diagonal or adjacent holes depending on the diameter of the chuck.) To loosen, turn the chuck to the left. Finish removing the chuck by hand.

To install a new chuck, hold the chuck shaft with a wrench, as described above, while using your hand to thread the chuck onto the lower end of the chuck shaft. Turn to the right to thread the chuck onto the chuck shaft. Use the chuck wrench, as described above, to tighten snugly. Make certain that the new chuck is properly tightened into position against the shoulder of the chuck shaft.

5. Replace gear housing cover [1].
6. Install the proper base plate for the can to be closed.
7. Replace the housing cover and tension spring.
8. Adjust the base plate pressure and seam rolls as outlined on the following page. **CAUTION:** Seam roll screws [9] have left hand threads and must be turned clockwise to loosen.

ADJUSTING THE STOP COLLAR

The purpose of the stop collar [95] is to regulate the movement of the starting lever [73]. Adjust as follows.

1. Loosen set screw in the stop collar.
2. Carefully move the starting lever to the left until the notch of the starting latch lodges on the cam housing protrusion marked "oil." While holding the starting lever in this position, turn the stop collar to the right until it fits against the slot in the starting lever.
3. Tighten set screw to hold the stop collar securely in position, making certain that the starting lever operates freely.

NEUTRAL POSITION

The machine is in a neutral position when both cam rolls [20] are in their innermost position and both seaming rolls are in their outermost position.

TIMING THE SEAMER

Timing of the seamer is proper when, at the end of the seaming cycle, both cam roll levers [21 and 25] are in neutral position. The driven pulley [78] turns freely. The seamer may be timed as follows.

1. Make sure power to seam is off.
2. Remove the drive belt [75]. If you are unable to roll the drive belt off of the driven pulley [78], loosen or remove the motor to allow more slack in the drive belt so it may be removed.

3. Expose the bevel gears by removing the housing cover [1], clip for tension spring [63] and tension spring [64]. Inspect bevel gears [6 and 7] for damaged cogs or teeth and replace as necessary.
4. Pull starting lever [73] to the left until it engages the starting latch [60].
5. Apply slight pressure (toward the right) to the starting lever and slowly turn the driven pulley [78] 10 turns counterclockwise until the starting latch [60] releases. The gap between the starting lever pin and the clutch cam should be no more than 1/4 to 3/4 inch.
6. If the seamer is not in time by the 10th turn, remove the cotter pin [100] from the drive shaft [69-1] and apply backward pressure against the driven pulley [78] to force the drive shaft to slip out of the small bevel gear. Remove the drive shaft bevel gear [6] while being careful not to move the larger bevel gear [7].
7. Slowly turn the driven pulley [78] counter-clockwise as outlined in Step 5 until the gap between the pin for the starting lever [73] and the “toe” of the clutch cam [70] is between 1/4 and 1 inch. Carefully align and re-insert small bevel gear [6] onto the drive shaft [69-1]. Do not allow the larger bevel gear to move during this procedure or your seamer will become out of time. (Model 24's must have the woodruff key [142-2] properly positioned in the keyway of the drive shaft [142-3]). Replace cotter key [100].
8. Check correct timing by turning the driven pulley [78] counterclockwise 20 revolutions while holding the starting lever [73] as described in Step 5. The seamer should stop in neutral position. If necessary repeat steps 6 and 7, moving the drive shaft bevel gear ONE cog at a time until the seamer is correctly timed.
9. Replace the cotter key and bend it snugly around the drive shaft. Replace gear housing cover [1] and tension spring [64]. Be sure the clip for starting latch [63] is placed properly to provide adequate tension on the spring to allow the starting latch [64] to engage when the starting lever [73] is pulled to start the seaming cycle.

NOTES: If you continue to have noise or “locking” problems after following the preceding instructions, check the starting lever [73], the pin for the starting lever [67], and the screw for the starting latch [79] for damage or excessive wear. Improper alignment of these parts may cause the pin for the starting lever [67] to strike the clutch cam [70] instead of passing by it.

Additionally, check the cam stud [66], the cam spring [65] and the spring stop pin [151] for damage or excessive wear. Check the cam spring [65] by removing the long “leg” of the spring from under the spring stop pin [151]. When the

cam stud [66] is at twelve o'clock position, the loose “leg” of the spring should point at one or two o'clock. Replace any of these parts as needed. After placing a new cam spring [65] on the cam stud [66], slightly squeeze the coil of the cam spring to be sure it is snugly positioned. Then, if necessary, used needle-nosed pliers to slightly bend the “leg” of the cam spring [65] near the coil to insure that it points toward the one or two o'clock position before placing the “leg” under the spring stop pin [151].

TO TIGHTEN V-BELT

The V-belt should be sufficiently tight to prevent slippage during the seaming operation. Adjust as follows.

1. Loosen mounting screws in motor base and insert thin washers to raise the motor and tighten the belt. Tighten screws securely.
2. Loosen set screws in the motor platform and adjust upward or downward on the posts for the motor platform. Tighten set screws.

CAM HOUSING INSERT

The insert [8-B] in the cam housing [8] is held in position by peening the casting. The insert is then machined to the correct dimension to allow the shoulder on the chuck shaft to protrude slightly. If it becomes necessary to replace the insert, be certain that it is properly seated, trimmed or machined so that it does not retard the turning of the chuck or the chuck shaft.

SEAMING ROLL ADJUSTMENTS

There are twenty (20) revolutions per seaming cycle, ten (10) for each seaming roll. The function of the first operation seam roll is to curl the cover hook and body hook into proper position. The function of the second operation seam roll is to complete the sealing of the can.

FIRST OPERATION

1. Make certain that electrical current to motor is OFF and that both cam roll levers are in neutral position (driven pulley turns freely without engaging the chuck).
2. Engage the automatic clutch by moving the starting lever [73] to the left and turning the driven pulley [78] counterclockwise until the driving pin [85] comes into contact with the “heel” of the clutch cam [70], at approximately the one o'clock position.
3. From this one o'clock position, turn the driven pulley exactly nine (9) revolutions counterclockwise. Now the first operation seam roll is at its innermost position in relation to the chuck.

- Loosen lock nut [16] and adjust set screw [17] until the first operation seam roll is snugly in position with the chuck. While holding the first operation (larger) gauge wire [40] in position between the chuck lip and the ground profile of the first operation seam roll, tighten the lock nut. **DO NOT PLACE WIRE IN GROOVE OF SEAMING CHUCK.** The larger diameter gauge wire [40] is the approximate THICKNESS of the first operation seam. There should be sufficient friction to turn the seam roll as the gauge wire is moved back and forth. Too much pressure may cause damage to the machine. Insufficient pressure may result in producing a short cover hook. Final adjustments may be made after a can is closed and the double seam inspected.

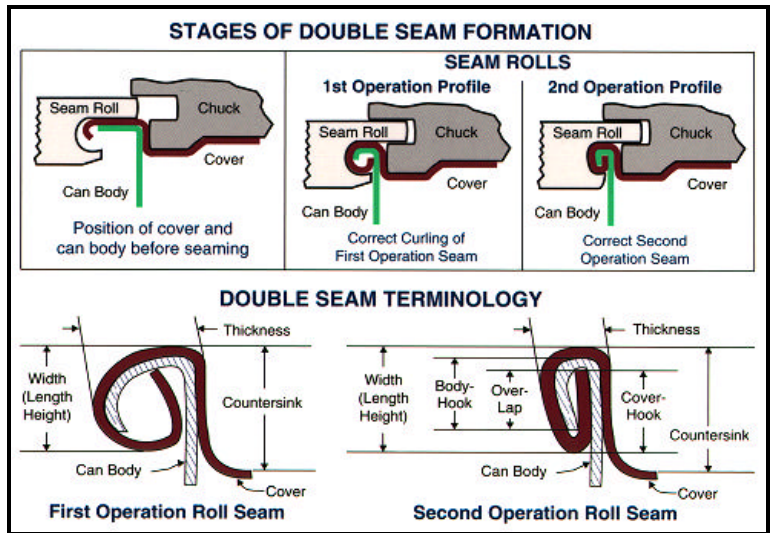

- Tighten lock nut [16]. Use a 3/6" allen wrench to keep screw [17] from turning when tightening the lock nut.

SECOND OPERATION

- After adjusting first operation roll, turn the driven pulley exactly nine (9) more revolutions counterclockwise. This is equivalent to eighteen turns from the original one o'clock position and brings the second operation seam roll to its innermost position in relation to the chuck.
- Loosen lock nut [16]. Place the second operation (smaller) gauge wire [41] in the groove of the second operation seam roll and adjust the screw [17] until the gauge wire fits snugly between the roll and the roughened or knurled edge of the chuck. Move gauge wire back and forth to allow sufficient friction to turn seam roll. **DO NOT PLACE WIRE IN GROOVE OF SEAMING CHUCK.** The small diameter gauge wire [41] represents the approximate THICKNESS of the second roll seam. Final adjustments may be made after a can is closed and the double seam inspected.
- Tighten lock nut [16]. Use a 3/16" allen wrench to keep screw [17] from turning when tightening the lock nut. Move the gauge wire back and forth to ascertain that sufficient friction turns the seam roll. Too much pressure may damage the double seam at the can body side seam and insufficient pressure will not produce a proper seal.
- Turn driven pulley two additional revolutions to place seamer in neutral position.
- Close a can, tear down and inspect the double seam. Make final adjustments of the seaming rolls and base plate pressure to produce essential body hook, cover hook, overlap and tightness recommended by the

container manufacturer or for a hermetically sealed can. NOTE: If you are unable to obtain the essential measurements recommended or a hermetically sealed container, you may need seam rolls with different profiles.

NOTE: When adjusting seam rolls, make sure you start from neutral position. Count carefully number of turns of driven pulley. Be sure seam roll is in its innermost position when inserting gauge wire. Also be sure to place the gauge wire in the groove of the seam roll, NOT in the groove of the chuck.

If your seamer shows a tendency to work overly hard, or "lock," check adjustments of the seam rolls. CAUTION: To avoid damage to your seamer, make sure that the seam roll is no closer to the chuck than to allow the small gauge wire to pass.

BASE PLATE PRESSURE ADJUSTMENTS

Proper base plate pressure is required to produce essential body hook and prevent slipping of can during the seaming cycle. Each base plate has an adjusting screw [57] and set screw [56] in its stem for making minute base plate adjustments as follows:

- Lift base plate out of plunger [29] and inspect the two metal discs [46]. Replace metal discs if there is any sign of undue wear or breakage. To replace the metal discs, first remove the plunger housing [30] and disassemble. Through the hole in the bottom of the plunger [29], insert a nail or punch and knock out the metal discs [46] and retainer spring [59]. Replace with new discs and reassemble, making certain that the retainer spring and metal discs are properly seated and that the entire assembly is adequately lubricated (oiled and greased).

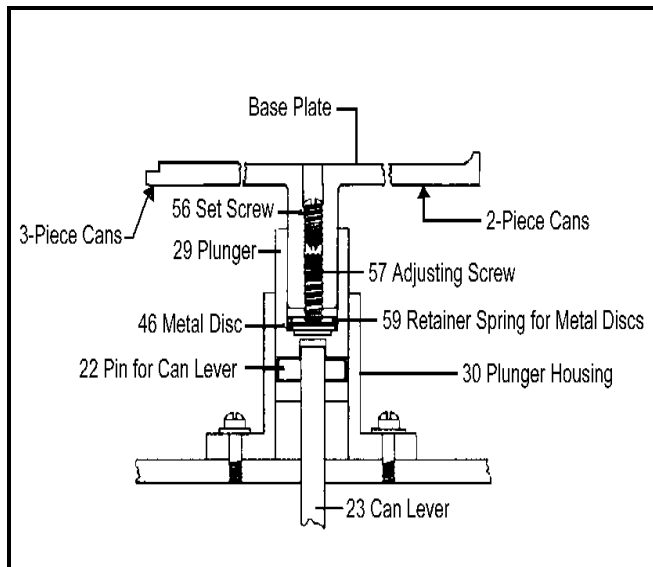

SECTIONAL VIEW OF BASE PLATE ASSEMBLY

2. Insert screwdriver in the hole in the top of the base plate and loosen set screw [56] by turning counter clockwise.
3. Turn adjusting screw [57] in the proper direction to lengthen or shorten effective height of the base plate, as may be required for proper tension (pressure). If you find it necessary to use pliers to turn the adjusting screw, be very careful not to damage threads.
4. Tighten set screw snugly. It may be necessary to hold the end of the adjusting screw firmly while tightening the set screw.
5. Make certain that the base plate assembly is properly lubricated (greased) and replace the base plate in the plunger.

NOTES: To achieve proper base plate pressure, the can must be raised the correct distance so that the cover (lid) is clamped against the seaming chuck. If the can lever [23] does not lock the can into place correctly, make sure the base plate you are using was fabricated for the can you are closing. Inspect the can lever [23] and wear plate [23-B] for damage or excessive wear. The wear plate [23-B] may be turned 180° to provide a new edge for locking the can lever into place. Replace parts as needed. (Always keep the can lever [23] well greased at its contact point with the wear plate [23-B].)

TESTING THE DOUBLE SEAM

Before seaming a large number of cans or when changing from one size to another, ordinary precaution must be used to determine that the seamer is in proper adjustment and a satisfactory seam has been achieved. Can seam inspection should be performed routinely to ensure the seamer is in proper adjustment.

Seam a test can and inspect the double seam for droops, vees, tightness or other possible defects. If your can manufacturer has provided you with seam specifications, take measurements of the seam to be sure your seam is within recommended tolerances. Dixie offers a Can Seam Test Kit that will enable you to measure different aspects of the double seam.

If you are testing only for an airtight or hermetic seal, various "rule-of-thumb" methods may be used such as immersion in water to check for air bubbles which may indicate leakage. Please check with your supervisor to determine the seam test method that is proper for your purposes.

Refer to instructions for adjusting seam rolls and changing from one size can to another to readjust your seamer as necessary to obtain a correct double seam.

MAINTENANCE OF SEAMER

With ordinary care, your Dixie seamer should give you excellent trouble free service if the following simple rules are observed.

1. Keep the seamer in proper adjustment at all times.
2. Replace worn parts as needed.
3. Clean thoroughly after each daily use.
4. Apply a few drops of lightweight oil to all exposed moving parts and in all holes plainly marked "OIL." At the start of each season and periodically thereafter, remove housing cover [1] and apply grease to gears [6] and [7]. Use fitting on gear housing cover to grease chuck shaft. Use fitting on gear housing [3] to grease drive shaft [69-1].

CHANGE PARTS AND REPAIR PARTS

When ordering parts, always furnish both the part number and the name of the part. When ordering change parts for cans, always send six (6) loose tops and can bodies of the size can(s) to be closed. These samples are require to fabricate the change parts. Please also provide seam specifications and seam roll profiles, if available.

REPAIR PARTS AND REBUILDING SERVICE

A complete stock of parts is maintained by Dixie Canner Company. Parts may be ordered as needed to replace worn or damaged parts.

Your Dixie Double Seamer may be returned to Athens, Georgia for complete rebuilding at a nominal service charge,

plus the cost of parts needed. When returning the machine for the rebuilding service, please observe the following:

1. Return the complete machine and include several cans and tops of the exact size and type closed. Properly crate the machine and cans for safe delivery and return shipment, and prepay the shipping cost.
2. Write a letter authorizing the rebuilding service and mention any problem with the machine. Also mention particular instructions concerning return shipment, urgency, and other pertinent instructions.

HELPFUL HINTS — TROUBLESHOOTING

Until the operator is familiar with the mechanics of the seamer and learns to recognize irregularities in the essential requirements of the double seam, the outline below is intended to help notice obvious defects and list some causes that may serve as a guide in correcting minor troubles.

MECHANICAL DEFECTS & COMMON CAUSES

- A. Can slips during seaming operation.
 1. Damage or lack of grease in the base plate, lift shaft, or height spacer.
 2. Insufficient base plate pressure. Worn or broken metal discs in base plate seat. Remove base plate from plunger and check metal discs [46]. Replace discs if broken or excessively worn.
 3. Worn or wrong size chuck. Make sure that the lid fits properly against the chuck; the lid should fit snugly but should not bind. Dixie chucks are custom fabricated to fit the specific end which you submitted when the chuck was ordered. If you have changed lid styles, you may need a new chuck.
 4. Seaming rolls binding on screws.
- B. Machine operates with undue noise or "locks."
 1. Machine not properly timed.
 2. Broken drive shaft bevel gear. Remove gear housing cover [1] and check drive shaft bevel gear [6]; if broken, replace as follows:
 - a. With machine in neutral position, remove cotter key [100], then push drive shaft [69-1] backwards and to remove old gear. Insert new drive shaft bevel gear [6]. CAUTION: To avoid changing the timing, do not allow larger bevel gear [7] to move while changing the smaller bevel gear.
 - b. Reposition drive shaft [69-1]; insert cotter key [100], then replace housing cover.
 3. Damaged or worn starting lever [73] or pin for starting lever [67].
 4. Damaged or worn cam spring [65], cam stud [66] and/or spring stop pin [151].
- C. Unusually loose seaming rolls.
 1. Seaming rolls or seam roll screws [9] worn. Seam

rolls should turn freely but without up and down movement or wobble. If undue wear is evident, replace with new screws and/or seam rolls.

- D. Seaming rolls do not return to neutral position.
 1. Seaming roll levers [12] binding.
 2. Seaming roll lever spring [11] weak or broken.
 3. Machine not properly timed.
- E. Machine seems to "labor" or freeze tight.
 1. Needs oil and/or grease.
 2. Too much base plate pressure.
 3. Seaming rolls too tight.
 4. Misalignment of moving parts.

DOUBLE SEAM DEFECTS & COMMON CAUSES

- A. Cut over. Unusually sharp edge at top inside edge of seam.
 1. 1st or 2nd operation seam roll set too tight.
 2. Worn seam rolls or worn chuck.
- B. Cut or fractured seam.
 1. Seam rolls set too tight.
- C. Droop or lap in double seam at or near can body side seam.
 1. Too much base pressure.
 2. 1st operation seam roll set too loose.
 3. Worn 1st operation seam roll.
- D. Excessive countersink depth.
 1. Too much base pressure.
 2. 1st operation seam roll set too loose.
 3. Chuck not properly seated in can top.
 4. Chuck groove worn.
- E. False seam. Body hook and cover hook do not overlap.
 1. Can top not properly seated on can.
 2. Damaged can flange or can top curl.
- F. Long body hook.
 1. Too much base pressure.
- G. Long cover hook.
 1. 1st operation seam roll set too tight.
- H. Short body hook.
 1. Insufficient base pressure.
 2. 1st operation seam roll set too tight.
 3. 2nd operation seam roll set too loose.
- I. Short cover hook.
 1. Too much base pressure.
 2. 1st operation seam roll set too loose.
 3. Worn 1st operation seam roll.
 4. Excessive countersink depth.
- J. Cover hook or body hook not uniform.
 1. Base plate or plunger worn.
 2. Chuck or seam rolls out of alignment.
- K. Droops, vees, wrinkles.
 1. Excessive base pressure.
 2. 1st operation seam roll too loose or worn.
 3. 2nd operation seam roll too tight.
 4. Defects in can body or top.
 5. Incorrect seam roll profiles.

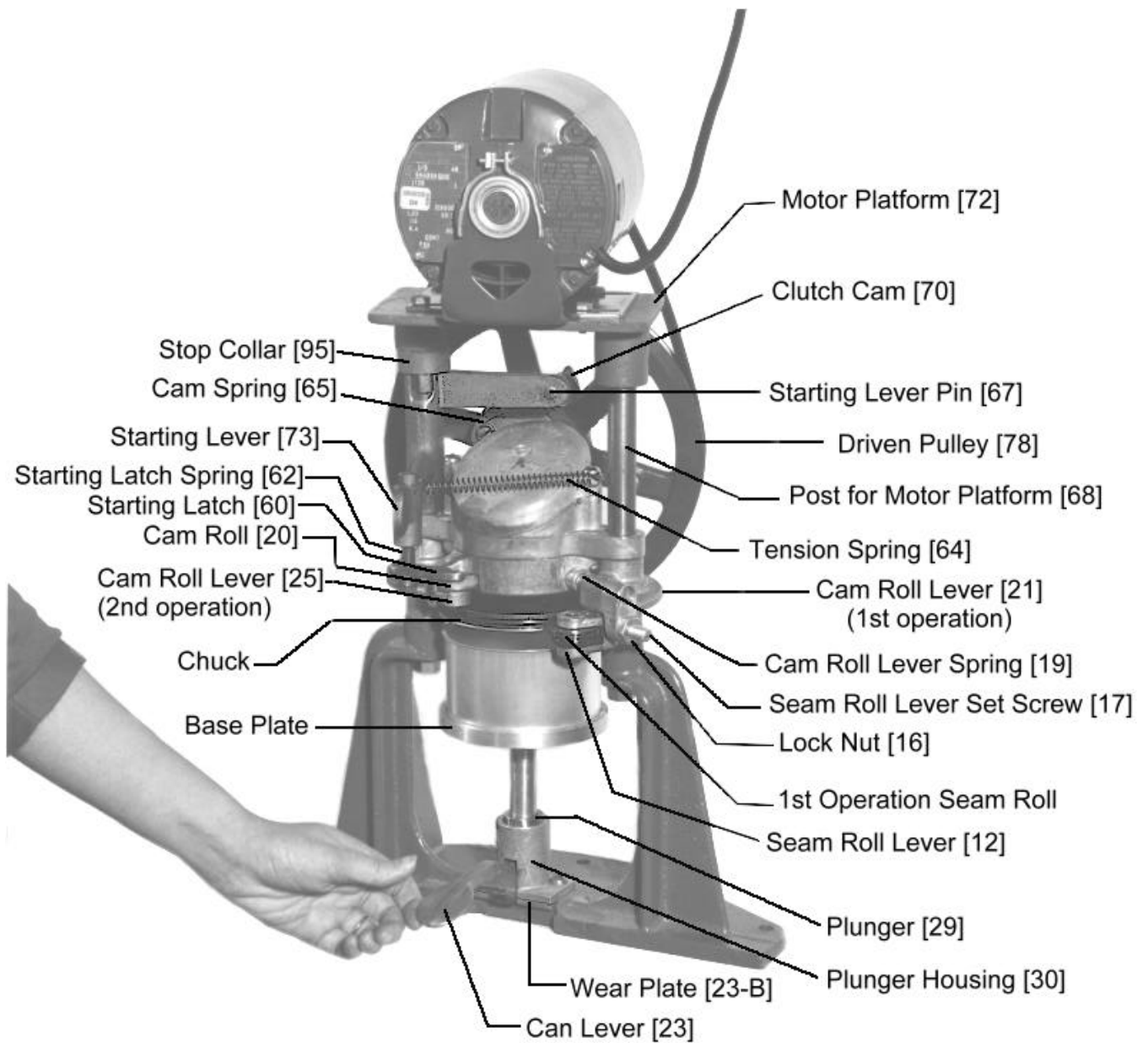

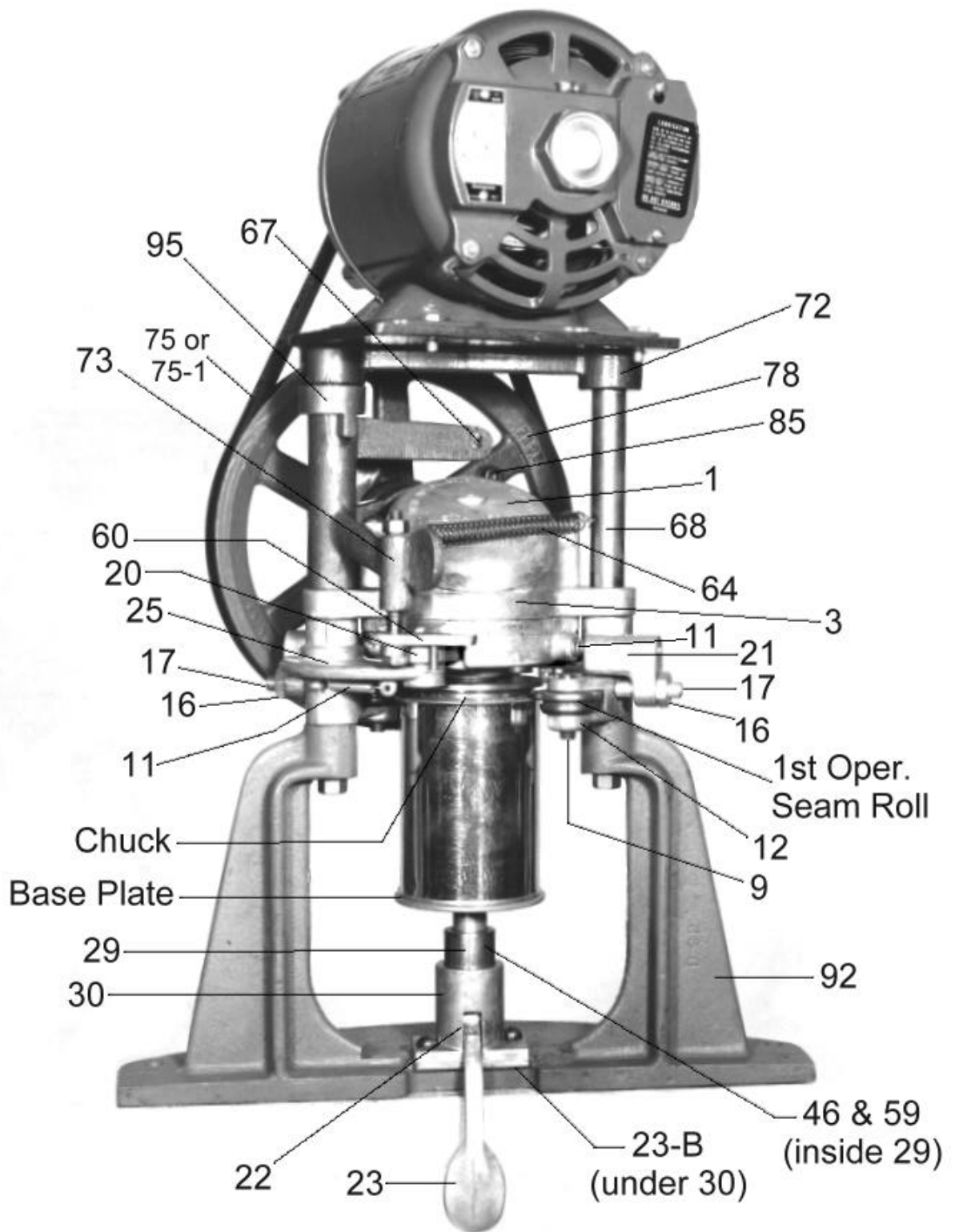

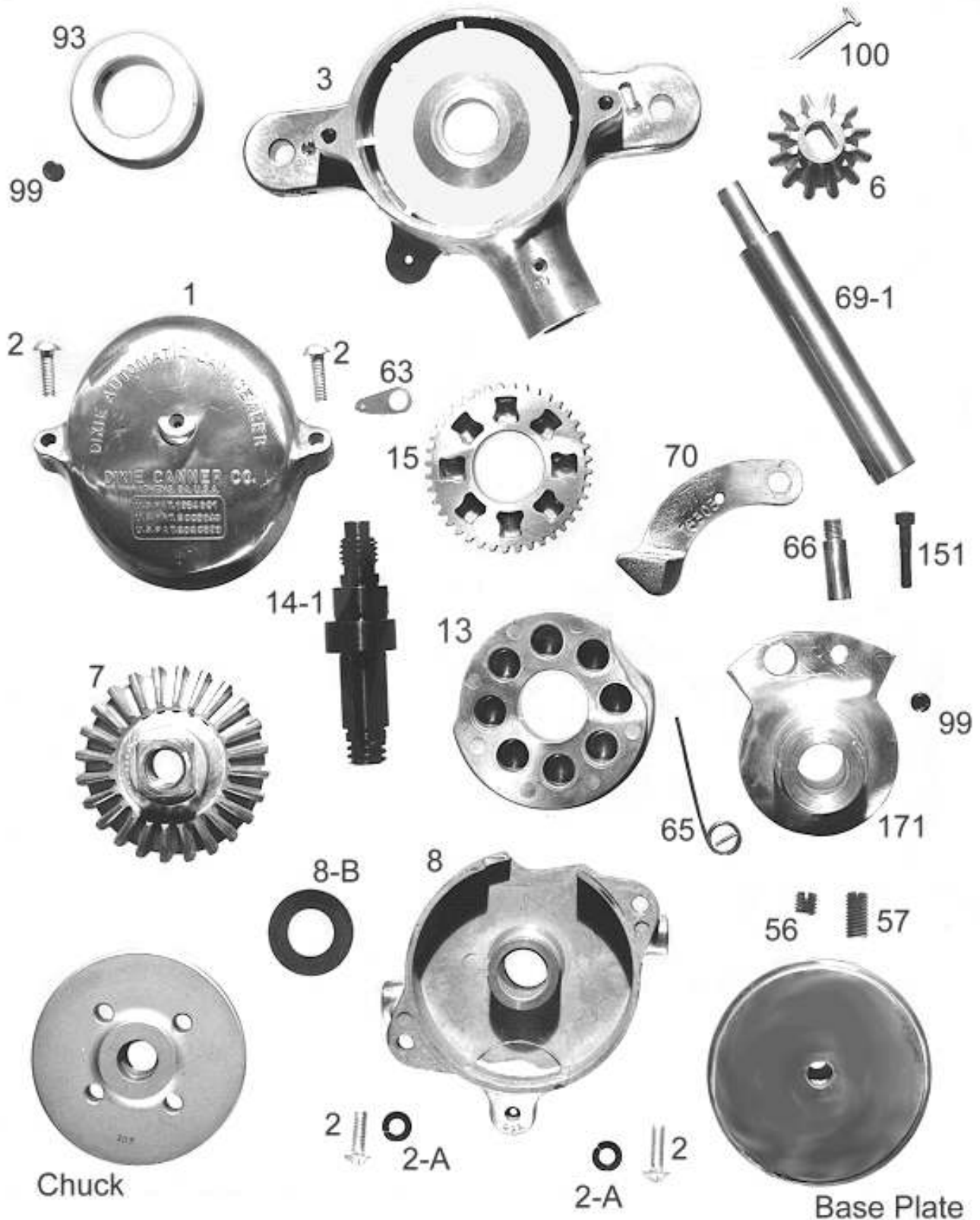

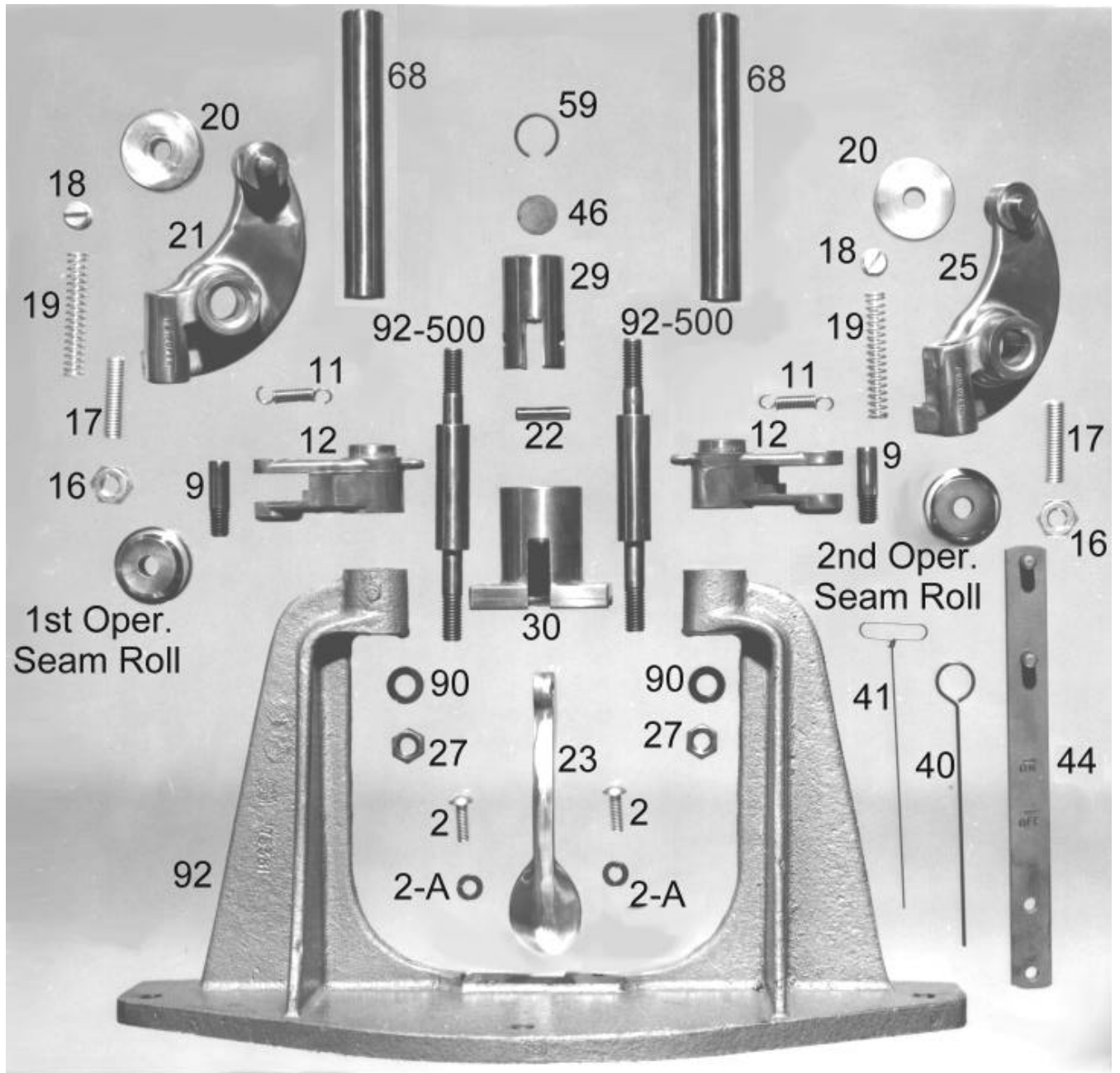

When ordering for Model 24 seamer, specify parts shown in inset below instead of parts 69-1, 6 and 7.

