

# The 3600RW RFID Label Printer Applicator



*SATO and ZEBRA  
Print Engines Available*



*Innovations in Labeling*  
[www.ctmlabelingsystems.com](http://www.ctmlabelingsystems.com)

**Packaging - Processing**  
**Bid on Equipment**  
1-847-683-7720  
[www.bid-on-equipment.com](http://www.bid-on-equipment.com)

# The 3600RW RFID Label Printer Applicator

## Features:

The 3600RW RFID Printer Applicator is a rugged and versatile, high speed, thermal transfer labeler used to encode, print and apply pressure sensitive RFID labels to various products. A Sato or Zebra print engine is integrated into an applicator to form a self-contained unit to print variable data.

These units use the latest developments in print engine RFID technology with upgrade capability.

The antenna is positioned immediately forward of the print head in both the Sato and Zebra units for reading/writing the next label out. The unique reject label accumulator shuttle advances under the applicator to receive reject labels. Rejected labels are print marked for visual identification.

In the event the shuttle accumulates too many rejects, a stop circuit is provided with an optional alarm. The shuttle mounting allows for easy removal of the rejected labels.

Assembled with Sato and Zebra printer modules, the unit can be mounted in various positions to apply labels to the tops, sides or bottoms of a multitude of products with its proven tamp-blow application. Small and large labels can be accommodated with its built-in bar codes and alpha-numeric fonts.

The plc control with user-friendly display interface offers quick access to set-up selection for application operating parameters.

Various onboard I/O signals are pre-wired to an external connector; optional features may be added in the field with minimum investment.

**NOTE: Label sizes dependent upon print engine model, also contact CTM Integration for custom sizes or shapes.**

Print capabilities include fonts of various sizes and styles with independent height and width expansion; includes OCR A/B.

Bar Codes include EAN 8/13, Code 39, Code93, UPC A/E (with extensions), Code 128, I 2 of 5, Maxicode, DataMatrix, PDF417, MicroPDF, CODABAR, MSI, and POSTNET.

The Graphics feature supports user defined fonts and graphics including custom logos.

Labeling Speed is dependent upon label size, print speed and application type.

Standard Machine Features include Heavy Duty Construction, Tamp Blow Applicator, External Valves and Controls, Operator Keypad & Display, 12" O.D. Label Roll, I/O Connection and Communication Port Connections, Reject label accumulation with labeler stop.

Optional features include Low Label/Low Ribbon, Out Of Label/Out of Ribbon, End of Web, Red, Amber and Green "Ready" Stack Lights.

## Dimensions

31.5" L x 27.5" W x 23.5" H

## Weight

Approx. 150 lbs.

## Electrical

108-132 Volts AC, 5 Amps, 50/60 Hertz, Single Phase

## Pneumatic

90 psi., 3-5 cfm

## Communications

RS 232, Parallel  
Others available

## Environmental

Operating: 41 F to 104 F  
(5 C to 40 C)

Storage: -4 F to 104 F  
(-20 C to 40 C)

## Printing Methods

Thermal Transfer With or Without RFID Active

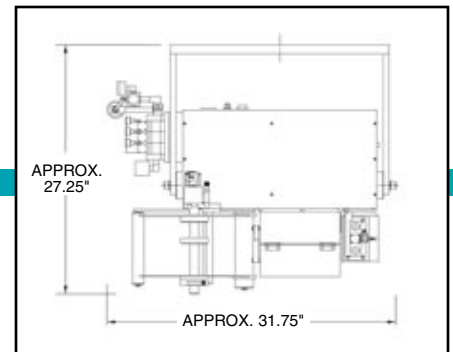
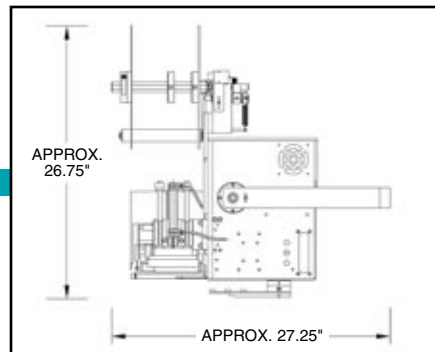
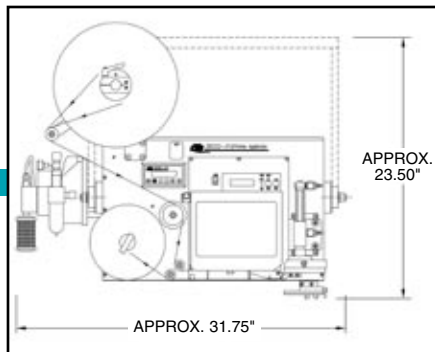
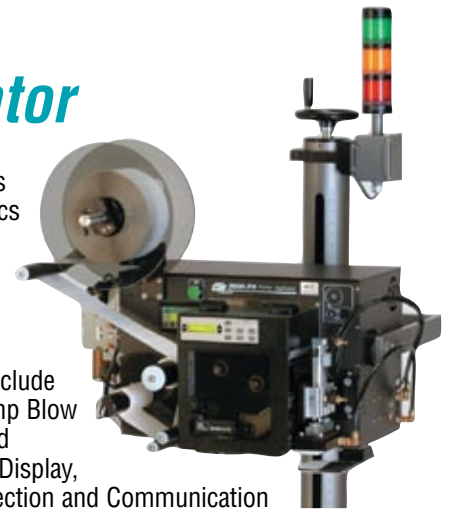

**Distributed By:**



1318 Quaker Circle  
P.O. Box 589  
Salem, Ohio 44460  
(330) 332-1800

[www.ctmlabelingsystems.com](http://www.ctmlabelingsystems.com)

**Packaging - Processing**

**Bid on Equipment**

**1-847-683-7720**

**[www.bid-on-equipment.com](http://www.bid-on-equipment.com)**

