

**RAP UP
SERIES 90
WRAP AROUND CASE SEALING**
By **COMPACKER, Inc.**



Packaging – Processing

Bid on Equipment

1-847-683-7720

www.bid-on-equipment.com

COMPACKER RAP UP SERIES 90

The RAP UP SERIES 90 is a custom engineered wrap-around case sealer. The machine's efficient design is tailored to your particular requirements and allows the

capabilities of automatic or semi-automatic case positioning, accumulation, loading and sealing. Through the use of production tested designs backed by a quarter century of COMPACKER

experience and proven performance, the RAP UP SERIES 90 provides optimum productivity and cost efficiently.

FEATURES

- * Automatic or semi-automatic
- * Handles low cost case blanks
- * Hot melt or cold glue
- * The Automatic accumulates and loads product in a variety of pack patterns
- * Speeds up to 15 cases per minute - dependent on line speed and product size
- * Easy change-over - most adjustments by hand cranks, no special tools required
- * Simple, easy maintenance
- * Electrical (P.C. Logic) or Pneumatic controls
- * Ruggedly constructed for years of reliable service
- * Many extra options available according to customer need

Here's how simply your RAP UP SERIES 90 will operate:

90-1 Semi-Automatic

(Packer Positioned Case and Product)

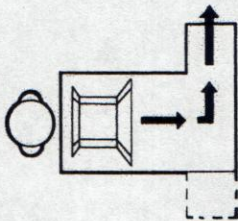

*May be left or right hand.

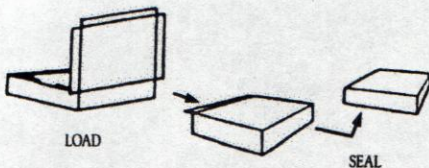

90-2 Semi-Automatic

(Automatic Case Positioning/Packer Load)

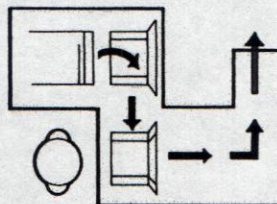

*May be left or right hand.

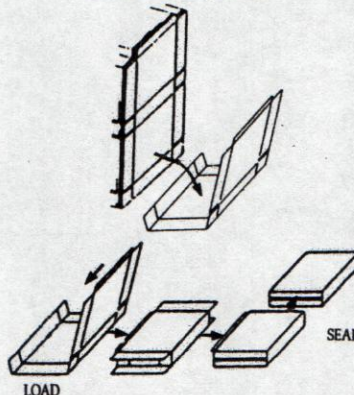

90-3 Fully Automatic

(Automatic Case Positioning, Accumulation and Load)

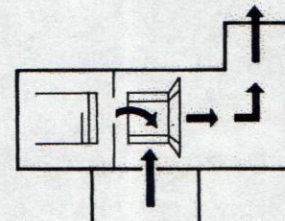

*May be left or right hand.

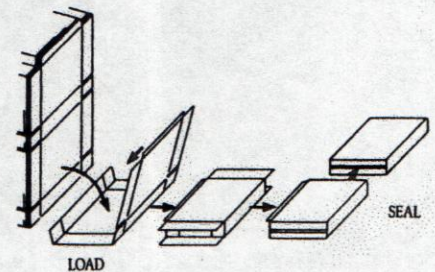

Another Efficient Packing System by



"THE SEAL OF APPROVAL"

9104 N. Zenith • P.O. Box 2026 • Davenport, Iowa 52809 • (319) 391-2751

Packaging - Processing
Bid on Equipment

1-847-683-7720

www.bid-on-equipment.com