

Case Sealing Equipment Designed to Fit Your Needs.

Compacker builds equipment that's designed to meet your job requirements. There are Compacker machines for erecting, loading and sealing corrugated cases, trays and wrap-arounds. All of them are backed by over 20 years of case packaging machinery experi-

ence. Our machines are built to stay on line day-after-day, year-after-year. In fact, some of our first machines are still in daily use. That's one reason why Compacker machines are now packaging some of the best known brands in the world. Let us design the packaging system best suited for your requirements.



Endpacker II

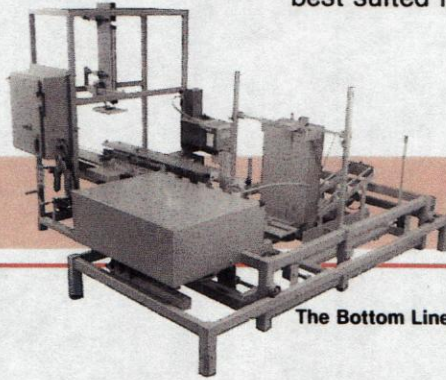

The Bottom Line

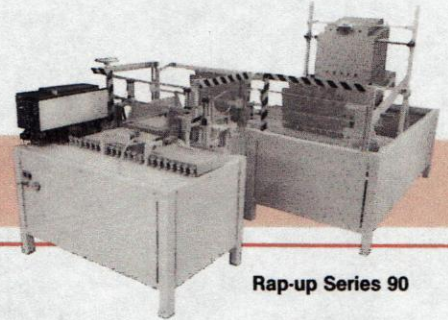

Rap-up Series 90

Case Packing Systems

- Systems to pack side or end load cases.
- Automatic or semi-automatic.
- Hot melt, cold glue sealing or pressure sensitive tape.
- Accumulators/loaders available to meet almost any need.
- Easily adjusts to a wide range of package sizes.

Case Erector/ Bottom Sealer

- Automatic or on-demand controls.
- Hot melt, cold glue or pressure sensitive tape.
- All adjustments made by hand—no special tools required.
- Handles a wide range of package sizes.
- Special options available.

Wrap-Around Case Sealer

- Handles low cost blanks.
- Automatic or semi-automatic.
- Hot melt or cold glue sealing.
- Accumulators/loaders available to meet almost any need.
- Easily adjusts to a wide range of package sizes.

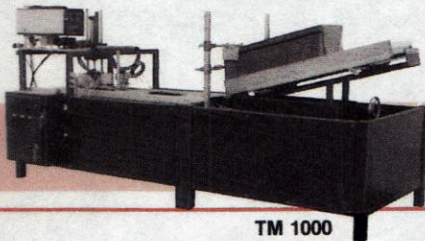

TM 1000

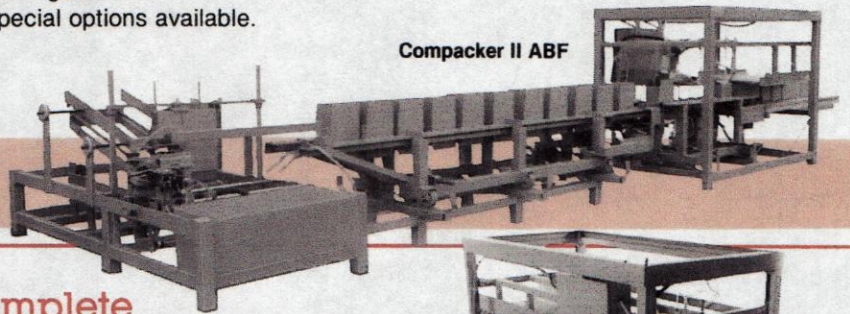

Compacker II ABF

Traymaker

- Traymaker or traymaker with loader.
- Automatic or semi-automatic.
- Hot melt sealing.
- Easily adjusts to a wide range of tray sizes.

Complete Packaging Systems

- Erects, positions for loading and seals the package; both top and bottom.
- Automatic bottom or top loading or manual loading.
- Automatic or on-demand controls.
- Hot melt, cold glue or pressure sensitive tape.
- Adjusts to a wide range of package sizes.

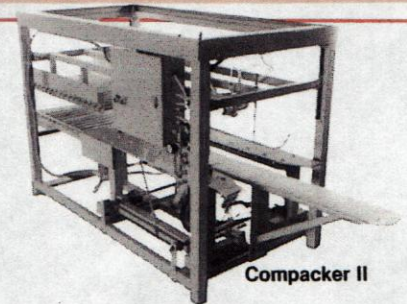

Compacker II

Top and Bottom Case Sealer

- Top only or top and bottom sealing.
- Automatic or semi-automatic.
- Compact size.
- Hot melt, cold glue or pressure sensitive tape.
- Quickly adjusts to a wide range of package sizes.
- Designs to fit most applications.



**For more information,
call Compacker: (319) 391-2751**

Davenport, Iowa 52809

**Packaging - Processing
Bid on Equipment**

1-847-683-7720

www.bid-on-equipment.com

COMPACKER Inc. for EFFICIENT PACKAGING SYSTEMS

Case Packer

- BOTTOM SIDE OR END LOAD STYLE CASES
- AUTOMATIC OR SEMI-AUTOMATIC MODELS AVAILABLE
- EASILY ADJUSTS TO A RANGE OF SIZES
- COLD GLUE OR HOT MELT

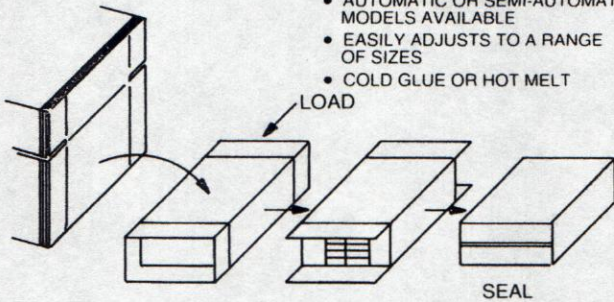

Case Erector/Bottom Sealer

- P.S. TAPE HOT MELT COLD GLUE
- WIDE SIZE RANGE
- AUTOMATIC OR ON DEMAND CONTROLS
- HAND ADJUSTMENTS-NO SPECIAL TOOLS

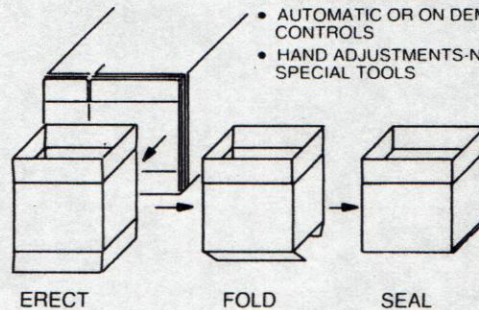

Wrap-Around Case Sealer

- AUTOMATIC OR SEMI-AUTOMATIC
- HANDLES LOW COST CASE BLANKS
- HOT MELT OR COLD GLUE
- EASILY ADJUSTS TO A WIDE RANGE OF SIZES

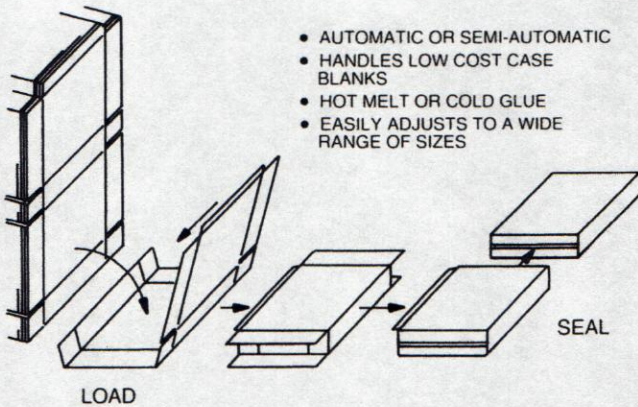

Traymaker/Loader

- AUTOMATIC OR SEMI-AUTOMATIC
- TRAYMAKER ONLY OR TRAYMAKER WITH CASE LOADER
- HOT MELT
- EASILY ADJUSTS TO A WIDE SIZE RANGE

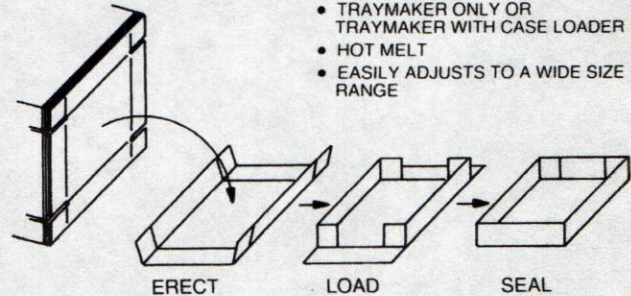

The Complete Packaging Line

- TOTALLY INTERGRATED PACKAGING LINE
- ERECTS, POSITIONS FOR LOADING, AND SEALS TOP AND BOTTOM
- VARIABLE OR SET SPEED CONTROLS
- HOT MELT, COLD GLUE, OR TAPE

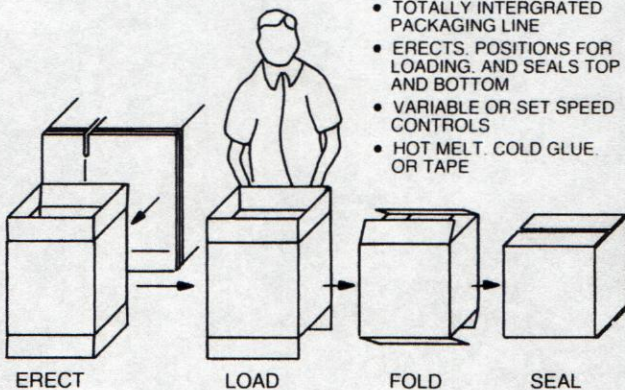

Case Sealer

- TOP ONLY, TOP AND BOTTOM
- P.S. TAPE, HOT MELT AND COLD GLUE
- QUICKLY ADJUSTS TO A WIDE SIZE RANGE
- COMPACT SIZE

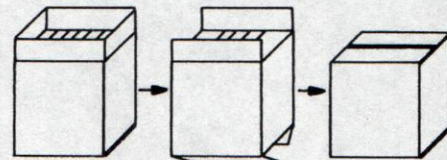

Packaging - Processing
Bid on Equipment

1-847-683-7720

www.bid-on-equipment.com

COMPACKER Inc.

9104 Zenith • Davenport, Iowa 52809
P.O. Box 2026 • (319) 391-2751