



CARRUTHERS

Packaging - Processing
Bid on Equipment
1-847-683-7720
www.bid-on-equipment.com

PRODUCT NAME



ADVANTEDGE

AE5000 1D • AE5000 2D

AE5000 3D • AE5000 LOGGER



SLICING, DICING, CUBING AND PORTIONING

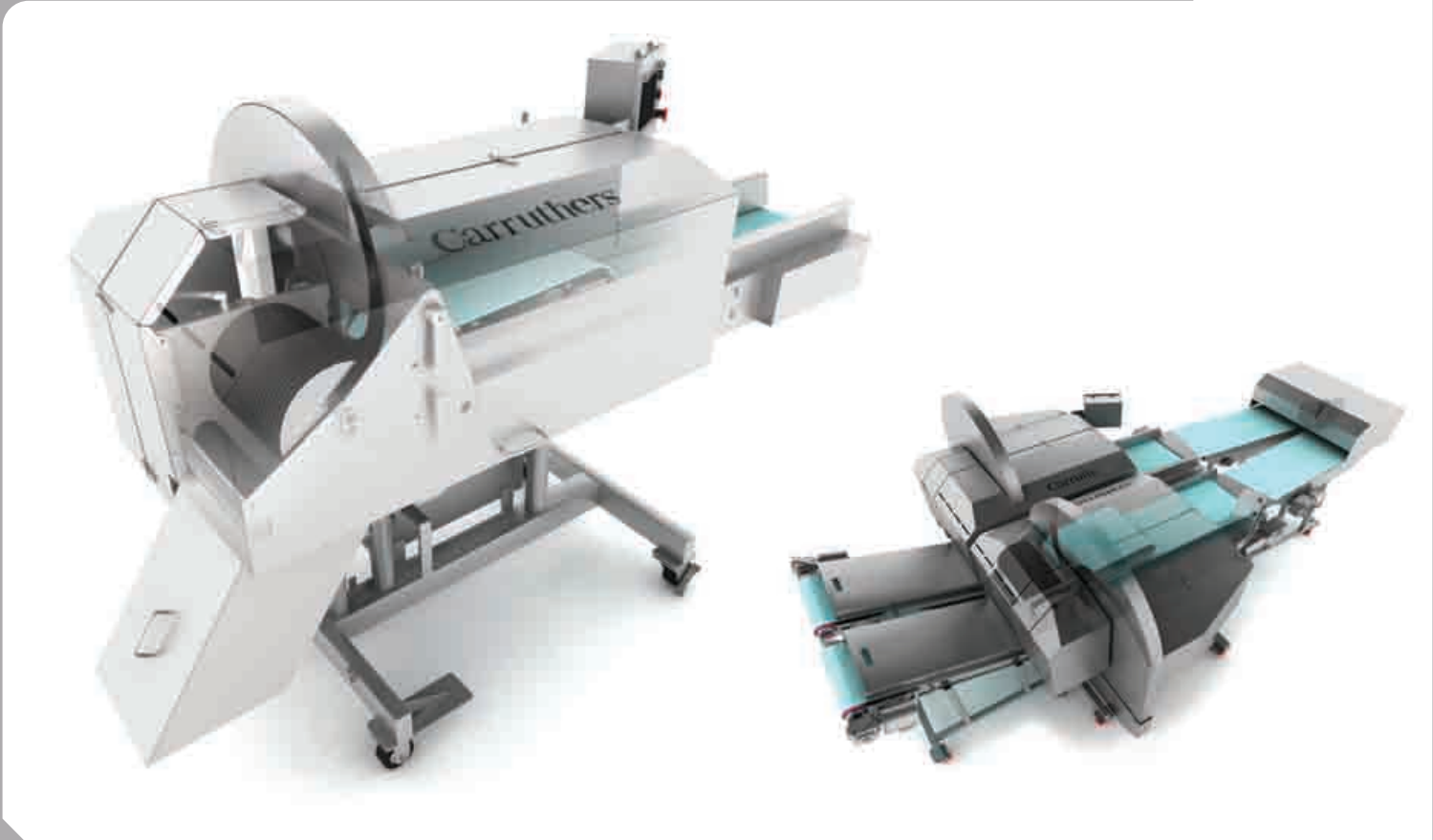

WWW.CARRUTHERS.US

441 30TH STREET, ASTORIA, OR 97103



CARRUTHERS. QUALITY. PERFORMANCE. INNOVATION.

ADVANTEDGE

SLICING • DICING • CUBING • PORTIONING

ADVANTEDGE FEATURES (AE5000 2D SHOWN)

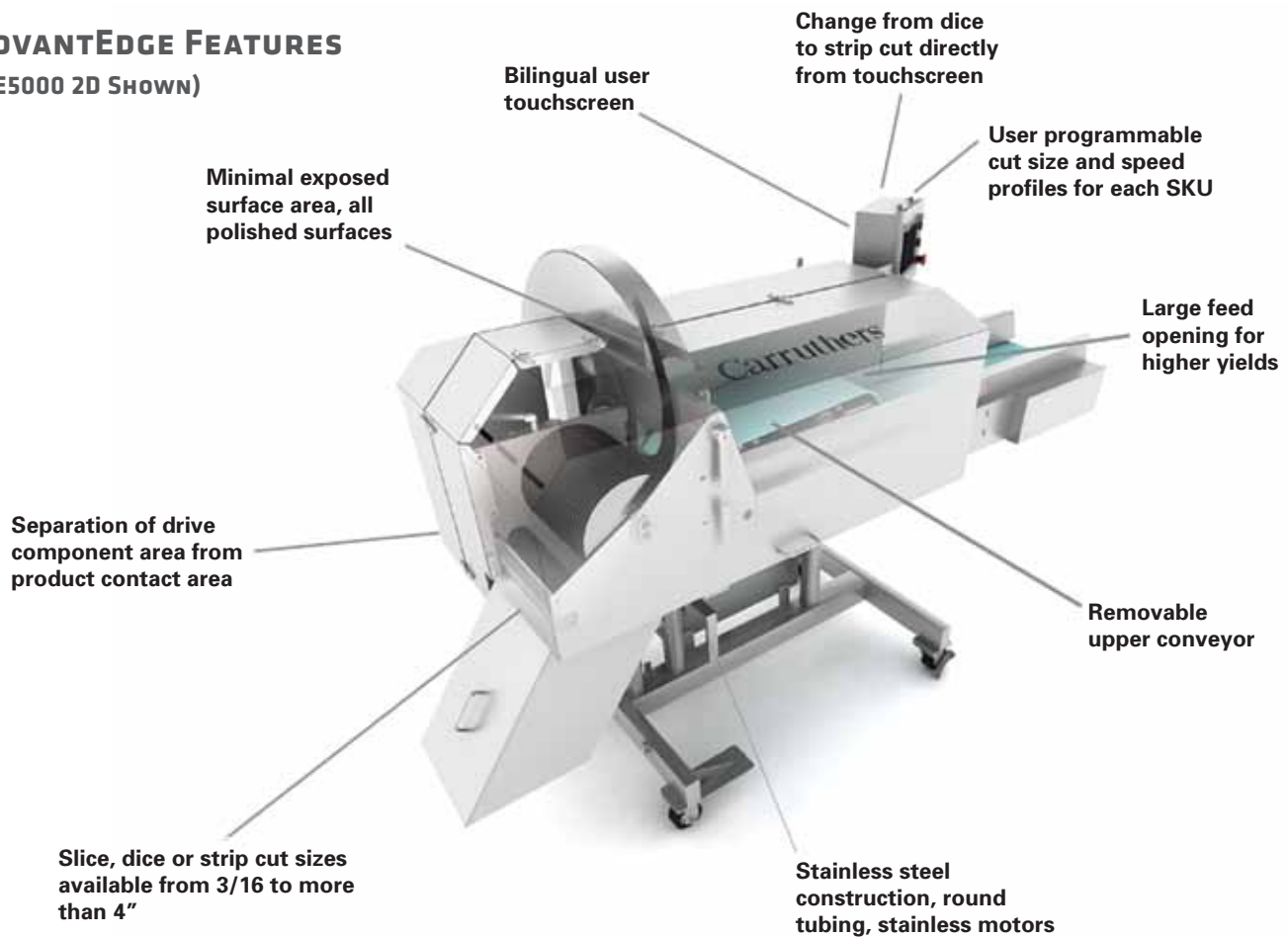

ADVANTEDGE AE5000 3D

Carruthers' patented cutting action uses conveyors to hold and control product. Low rpm, stay-sharp blades produce accurate, consistent sizing without ripping and tearing.

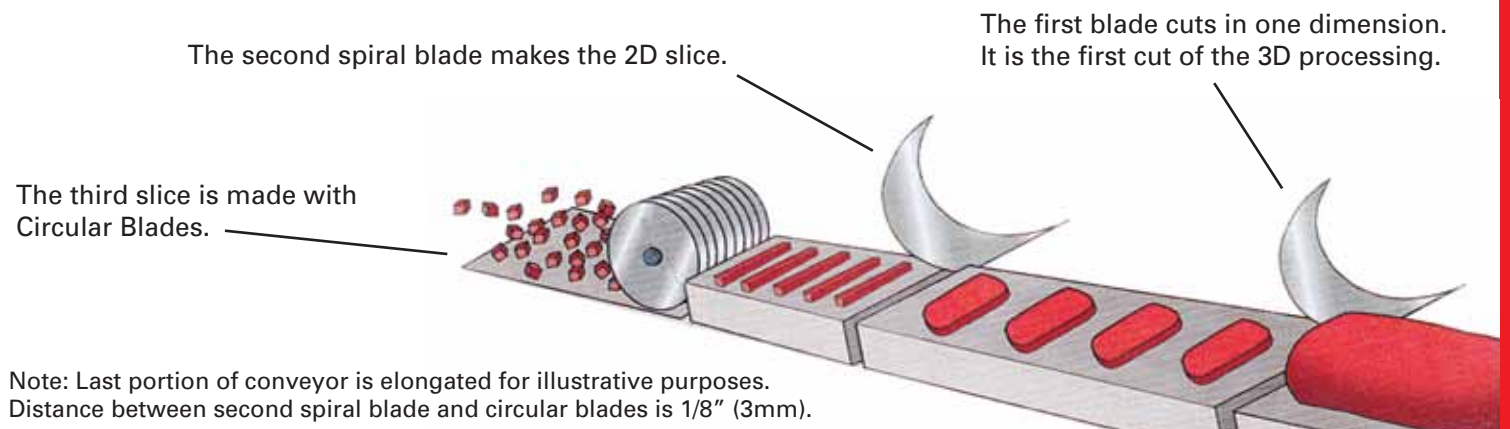

SIZE REDUCTION EQUIPMENT

ADVANTEDGE MODELS

THE CARRUTHERS ADVANTEDGE AE5000 DICER IS DESIGNED TO PROVIDE YOU WITH THE ADVANTAGE YOU NEED TO OPERATE IN TODAY'S FOOD PRODUCTION ENVIRONMENT.

ENGINEERED FOR PRECISE CUTTING • SIMPLISTIC DESIGN/EASE OF OPERATION • OSHA APPROVED

SLICING



ADVANTEDGE MODEL AE5000 - 1D & SHINGLING CONVEYOR

One-dimensional portioner with Butt Free Blade ensures continuous slicing throughout the entire product.



DICING



ADVANTEDGE MODEL AE5000 - 2D

Two-dimensional dicing of products leaves natural height of product as third dimension. Slicing, dicing, and strip cutting capability all on one unit.



CUBING



ADVANTEDGE MODEL AE5000 - 3D

A combination of the 1D and 2D models provides complete versatility for cubing.



PORTIONING



ADVANTEDGE MODEL AE5000 - LOGGER

A one-dimensional portioner for deli log meats and snack sticks. Specify lengths or numbers of lengths for portion control accuracy of + or - 1/16" and automatically remove ends and clips.



ADVANTEDGE

SLICING • DICING • CUBING • PORTIONING

MAXIMIZE YIELDS

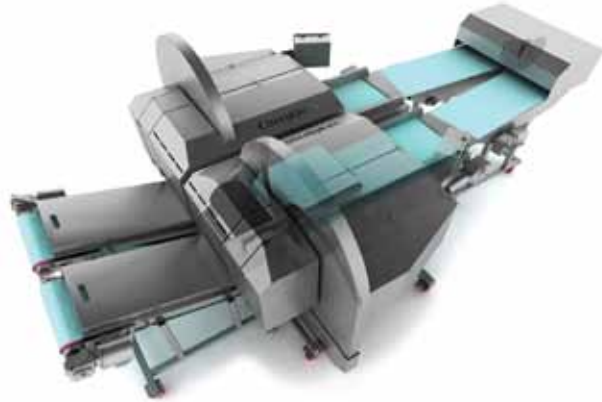

AE 5000 SIZE REDUCTION SYSTEM FOR 40" WIDE BELT PROCESSING

- Keeps "sheet" product intact to minimize fines
- Uses minimal floor space, gets product from oven to chiller quicker
- High throughput, over 15,000 pounds/hour, delivers greater production capacity
- Designed to be separated for cleaning and maintenance

SPECIFICATIONS

PRODUCT TYPE

Handle tough, fatty products and those having sinew or gristle such as beef brisket, beef silverside, flats, top round, chicken and turkey breast or leg meats, pork skins, tripe. Gently handle fragile products such as whole leaf lettuce, melon, and injected cooked chicken. Finished product is clean cut with no connective pieces, no loss of structure, and no moisture loss.

SIZE OF PRODUCT

Product sizes up to 12" wide x 5" tall can be processed.

TEMPERATURE

Dice fresh product at any temperature, or fully cooked hot right from the oven. No need to chill or temper the meat in order to dice effectively.

FLEXIBILITY

Slice, dice, strip, and maintain grain orientation. Provides full range of slicing/dicing from 1/8" to over 3" on the same machine.

CONTINUOUS FLOW

Processes a continuous flow of product, does not require an operator as batch mode machines do.

THROUGHPUT

Capacity of a 2D dicer on beef brisket (about 1-1/2" tall meat) on a 1" x 1" dice (i.e. stew meat) will be over 5000 lbs/hour. Lesser throughput will be experienced on smaller dice sizes; higher throughput may be achieved on larger cuts. Maximum belt speed of 40 ft/min.



CARRUTHERS. QUALITY. PERFORMANCE. INNOVATION.

SIZE REDUCTION EQUIPMENT

ADVANTEDGE

SLICING • DICING • CUBING • PORTIONING

AE5000 LOGGER • DIMENSIONS

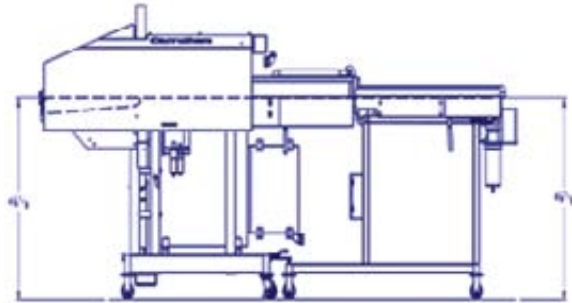
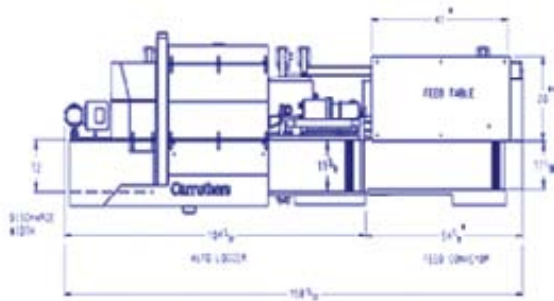

AE5000 2D • DIMENSIONS

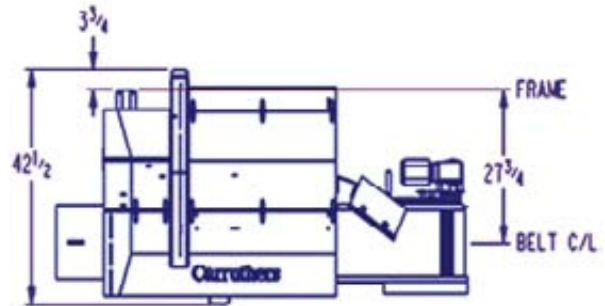
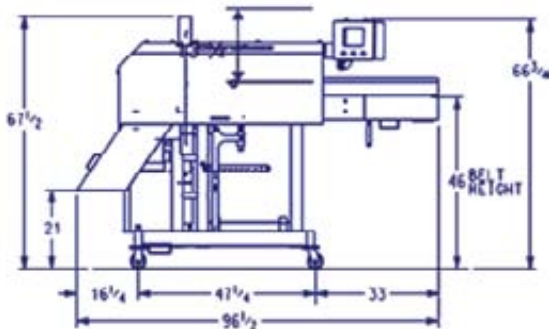

AE5000 3D • DIMENSIONS

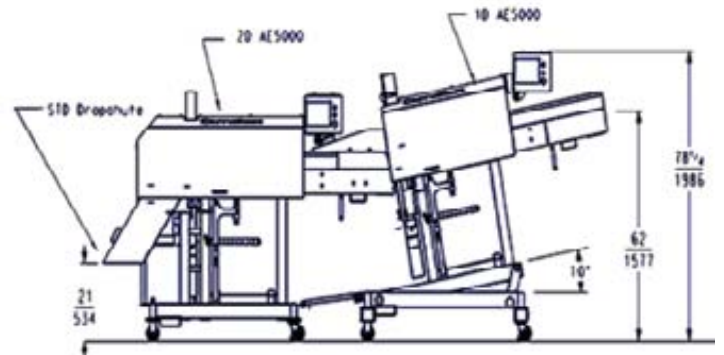
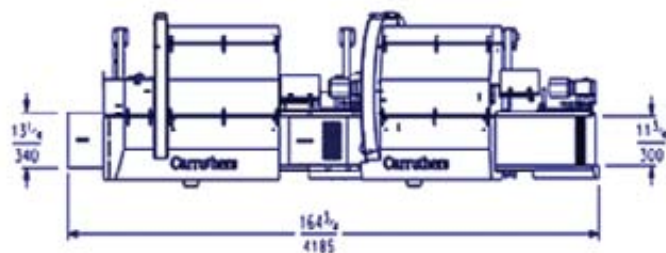

SIZE REDUCTION EQUIPMENT

ADVANTEDGE

SLICING • DICING • CUBING • PORTIONING

ACCESSORIES



GANG KNIFE SHARPENING SYSTEM



CLEANING CART (FULL SIZE)



TAKE AWAY CONVEYOR



SPIRAL KNIFE SHARPENING SYSTEM



CLEANING CART (HALF SIZE)

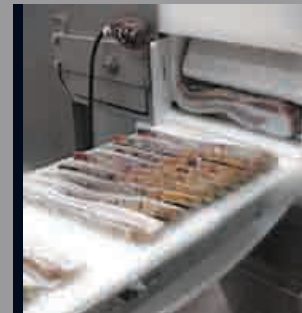

SHINGLING CONVEYOR

OPTIONS



GANG KNIFE

- Sizes from 4mm to 6" spacing
- Full cartridges or change parts
- Strip cut only cartridge
- Slicing only cartridge

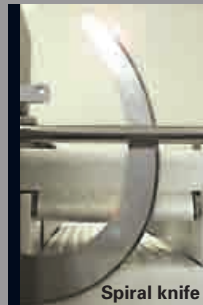

Spiral knife



Butt-free blade

SPIRAL KNIFE

- 1, 2, or 3 blades can be used
- .062 or .100 thickness
- Teflon coating for sticky products



SMART SLICE

- Servo drive motors
- Product leading edge sensor



SS MESH BELTS



CARRUTHERS

MARLEN INTERNATIONAL

441 30th Street • Astoria, Oregon 97103

Telephone: 503-468-0441 • Fax: 503-296-5800 • www.carruthers.us