

Packaging - Processing
Bid on Equipment

1-847-683-7720

www.bid-on-equipment.com

BD Bottling Development

'S' BOX

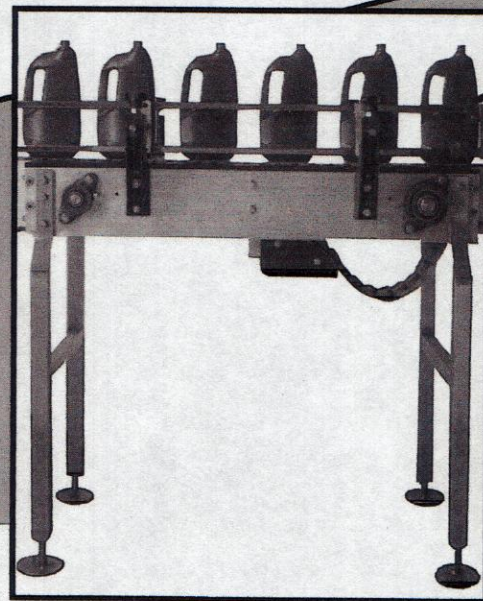
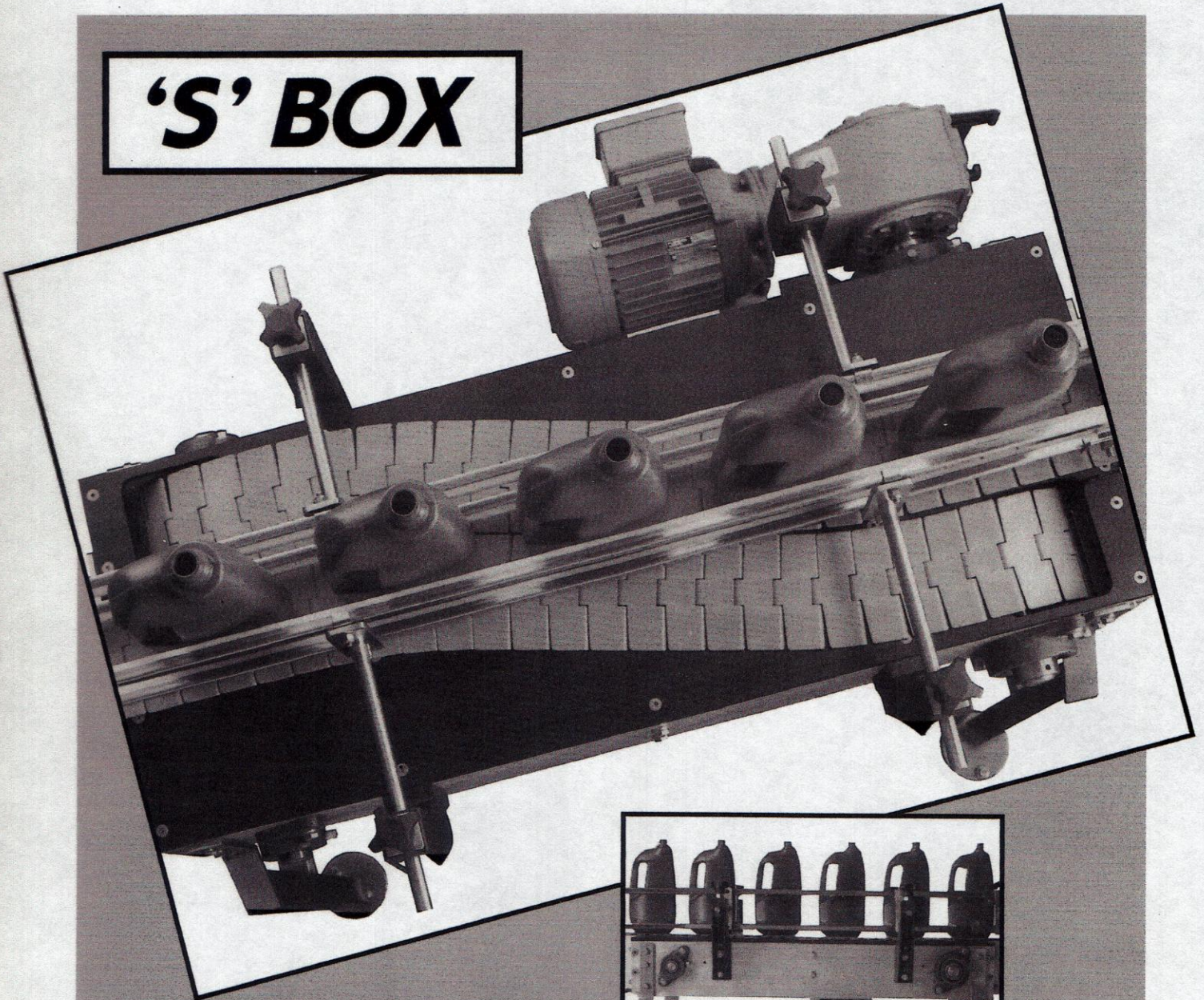

Straight line cross-transfer box

— for transfers and changeovers which are **speedy, smooth & simple!**

'S' BOX

TOP VIEW

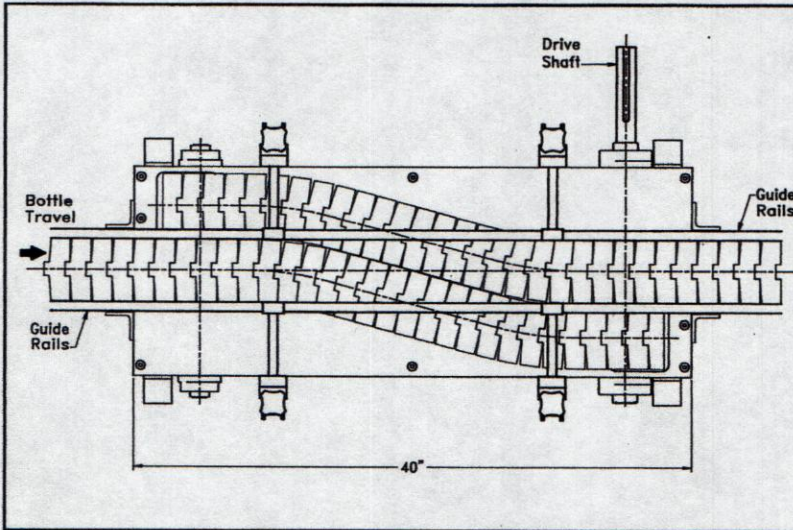

SIDE VIEW

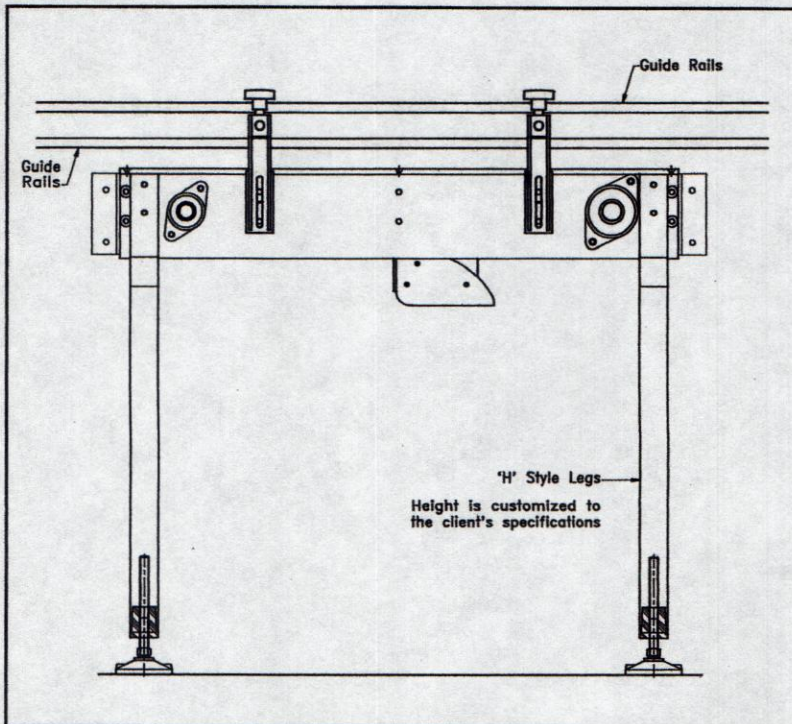

SAVES MONEY

- eliminates scuffed labels and broken bottles by guiding the bottles gently in a straight line from one conveyor to another
- less expensive than conventional installations

SAVES TIME

- eliminates time lost due to bottles jamming or tipping during transfer between conveyors
- changeovers are very quick because the distance between the guide rails is the only adjustment
- no need to bend guide rails

VERSATILE

- adjusts quickly to accommodate almost any size of container.
- flex chain design of the conveyor means that even very small bottles cannot fall between the cracks

EASY TO INSTALL

- comes with its own adjustable legs to fit readily into your line design

For more information contact:

Joseph E. Seagram & Sons, Limited

Bottling Development
592 Colby Drive • Waterloo
Ontario • Canada • N2V 1A2
Telephone (519) 886-9090
US only 1 (800) 225-2242
Fax (519) 886-9306

Sales Agent:

Packaging – Processing
Bid on Equipment

1-847-683-7720

www.bid-on-equipment.com