

Continuous Bag Form, Fill and Seal Machine

SVE 3800 AB



BOSCH

Invented for life

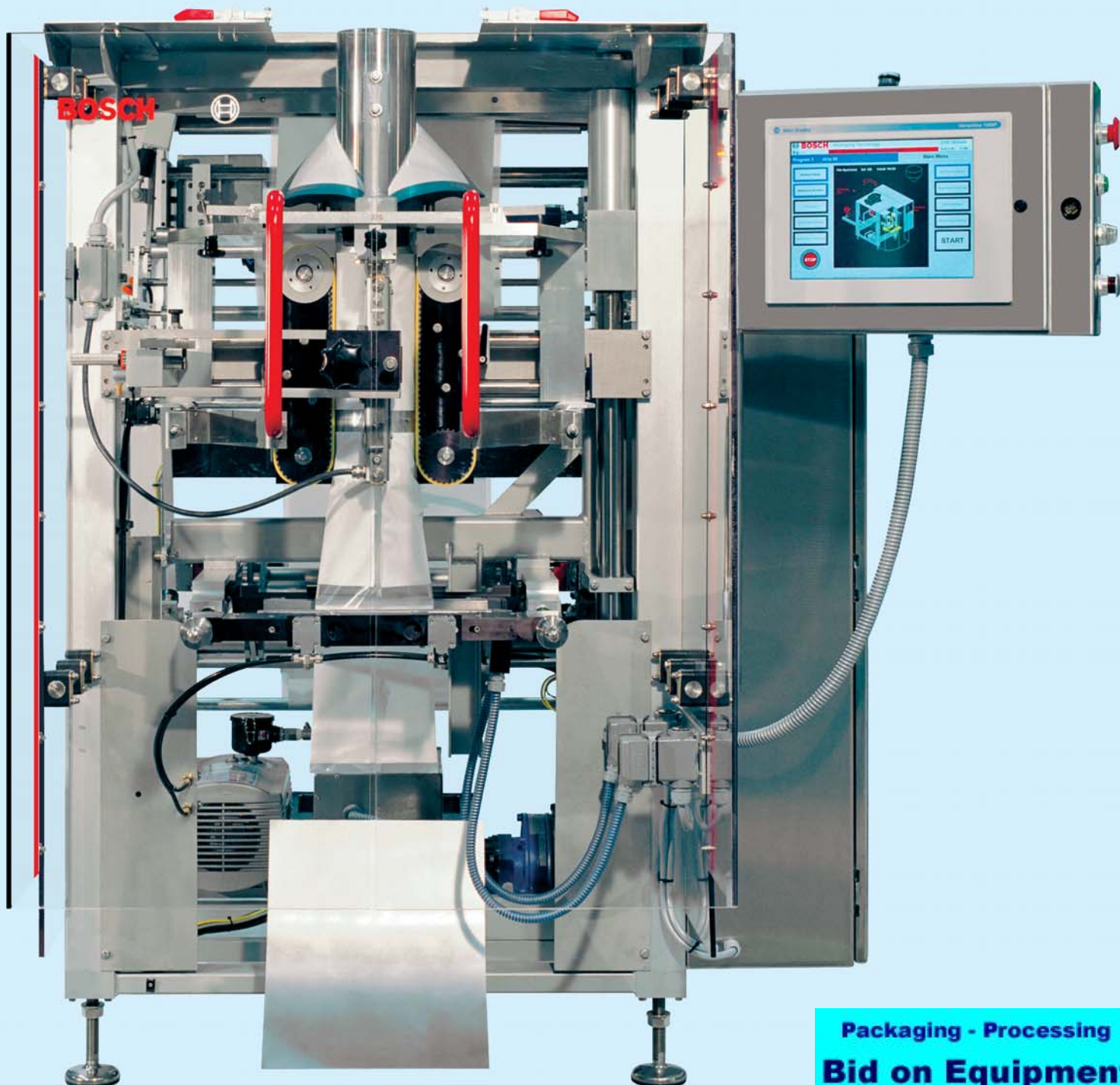

Packaging - Processing
Bid on Equipment
1-847-683-7720
www.bid-on-equipment.com



Snacks



Cereal



Fresh Produce

High Performance Packaging for any Product

The Bosch SVE 3800 AB is a high performance, wide range, large format bag form fill and seal machine. This machine is capable of speeds up to 120 packages per minute running bag widths ranging from 2 inches to over 15 inches wide and bag lengths of 3 inches to 24 inches long. The SVE 3800 combines the best features of Bosch's continuous motion, servo technology with a Rockwell/Allen-Bradley based machine control system. The cost effective SVE maintains the proven Bosch film handling and sealing system featuring servo motion control for both film handling and independent jaw movement. The SVE 3800 AB is designed around a Rockwell/Allen-Bradley integrated control system for motion, I/O, and communications. Operator interface is through an industrial PC based full color touchscreen. The touchscreen also provides operator/maintenance access to a full suite of online machine documentation which includes schematic diagrams, machine assembly drawings and complete parts list. This results in real time support and enhanced diagnostics capabilities including remote access and flexible, seamless integration for Ethernet networks and Data Acquisition Systems.

The packaging material is drawn-off continuously and precisely by the vacuum supported servo belt indexing system, without any friction between the belts and forming tubes. At the same time, a strong longitudinal seam with minimal overlap is formed. Synchronously with the packaging film advance, the cross seal jaw makes the top and bottom seals and the finished bag is separated and discharged.

Servo drives also electronically control the vertical and horizontal motions of the cross seal jaws. One servomotor is dedicated to the vertical movement of the cross jaw assembly. The second servomotor drives the opening and closing of the cross seal jaws. These features facilitate many different movement profiles to enhance sealing capabilities including product stripping.

The SVE 3800 AB is designed to process a wide variety of packaging films. These include heat sealable and polyethylene materials. The SVE 3800 AB readily interfaces to many different filling systems such as weighers, augers, volumetric fillers, counters and other custom designed infeed systems. Also, it is easily synchronized to downstream equipment such as conveyors, cartoners and case packers.

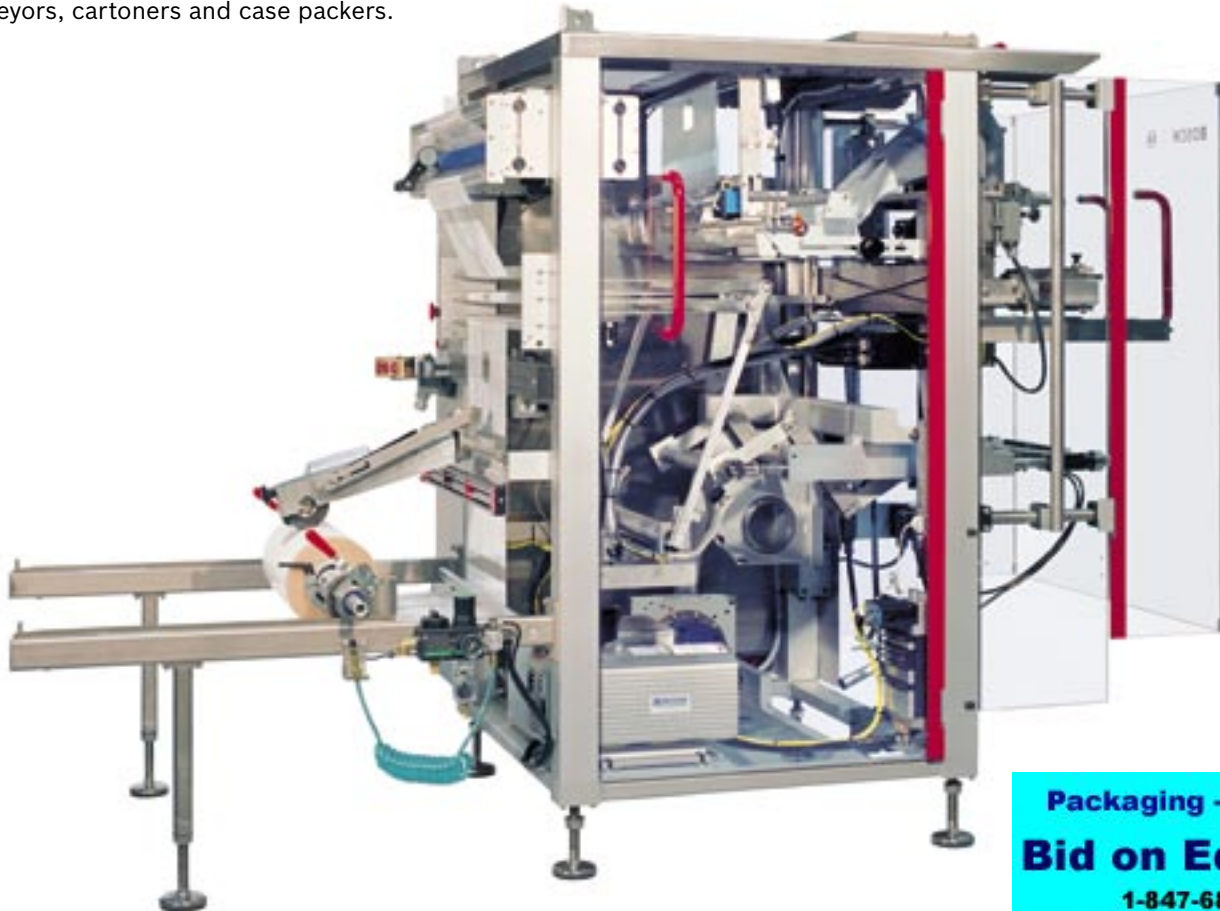

Packaging - Processing
Bid on Equipment
1-847-683-7720
www.bid-on-equipment.com



Coffee



Frozen Vegetables



Poultry

You Benefit from Bosch Innovation

Material handling

- Continuous material advance at relatively low speed for maximum reliability
- Gentle material handling enables use of thinner, lower-cost packaging materials
- Improved tracking minimizes required film reel width
- Consistent, longitudinal seam quality means fewer rejects

Flexibility

- Packages free flowing, particulate and powder food products, such as confectionery, baked products, cereals, snacks, luxury consumables, dried fruit, and IQF frozen food and vegetables

Lower operating costs

- Off the shelf Allen-Bradley control components
- No lubrication in standard configuration
- Low maintenance and service
- High efficiency in all applications
- Modular engineering for easy component replacement

Operator-friendly design

- Low overall height
- Wide-opening double doors
- Easily accessible interior
- Process monitoring and data-input validity checking
- Fast, easy one-part size change
- Quick change jaws and knife available

Easy programming

- Servo technology permits program change with the touch of a button
- 100 program memory
- Bag types: pillow/side-gusseted/block-bottom

Other standard features

- Open frame design for excellent accessibility
- Extensive use of stainless steel and other non corrosive materials for use in a wide variety of plant environments
- State of the art servo technology for material transport and cross seal jaw motions
- Vacuum material transport system
- Vacuum supported splicing table
- Photo-Eye for print-registered film

Options

- Quick change knife and jaw sets
- Automatic web tracking
- Reel support for 2 packaging material reels
- Gusseting device
- Integration of a wide variety of code daters and printers
- Variety of hole punch options (full, partial, "Euro")
- Tear notch for easy bag opening
- Gas flush options for MAP with auto shut off
- Variety of bag discharge chutes and flipping devices
- Optical sensor for automatic control of web tracking
- Harsh environment configuration including NEMA 4X electrical design
- Filling tube dust extraction
- Forming set with integral shut off for product staging or clean product cut off
- PHS (poly-heat seal) system for weldable materials (i.e., LPDE)
- Heated film splice bar



Pillow Bag



Gusseted Bag



Flat/Block Bottom

Closure Option is Available in Zipper



State of the art, Allen-Bradley intuitive machine interface



Complete operator's manual on machine interface with errors hot-linked to troubleshooting



Parts manual on machine interface including detailed assembly drawings for parts identification

Continuous Bag Form, Fill and Seal Machine

SVE 3800 AB Technical Data

Specifications

Flat Bag	Width	(60mm - 380mm) 2-1/3 - 15 inches
Stand Up Bag	Width	(50mm - 330mm) 2 - 13 inches
	Depth	(30mm - 140mm) 1 - 5-1/2 inches
	Width + Depth	(380mm maximum) 15 inches
Bag Length		(75mm - 600mm) 3 - 24 inches
Machine Speed*		Up to 120 bpm *Speeds are product and film dependent
Packaging Material	Width	(800mm maximum) 32 inches
	Diameter	(650mm maximum) 26 inches
	Core ID	(75mm) 3 inches
Power Consumption		3 phase 208-575 V 1 phase 208-240 V optional 10 KVA max (varies with film type and speed)
Air Consumption (will vary based on options)		3.8 CFM @ 75 PSI for PE .38 CFM @ 75 PSI for HS 3/4 inch infeed minimum
Machine Control		Allen-Bradley RS Logix 5000™ series
Drives		Allen-Bradley Ultra 3000, SERCOS
Servo Motors		Allen-Bradley MPL™ Series
HMI		Windows XP™ based 15" touchscreen Screens developed in Wonderware™ Allen-Bradley RSview™ optional
Pneumatics		Operated via field bus
Proximity Switches		Connected on field bus

Illustrations and specifications contained in this brochure are for general information only. All dimensions and specifications are subject to change without notice.

Robert Bosch Packaging Technology, Inc.
9890 Red Arrow Highway, P. O. Box 579
Bridgman, MI 49106-0579

Telephone 269-466-4000
Facsimile 269-466-4040
Website www.boschpackaging.com

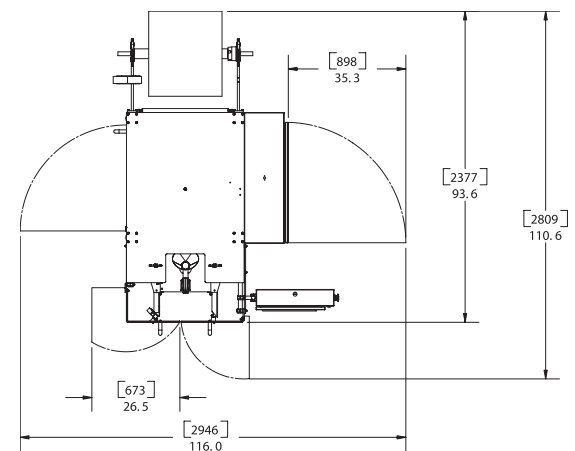
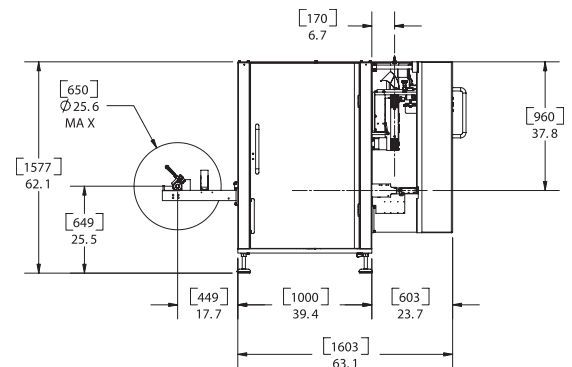
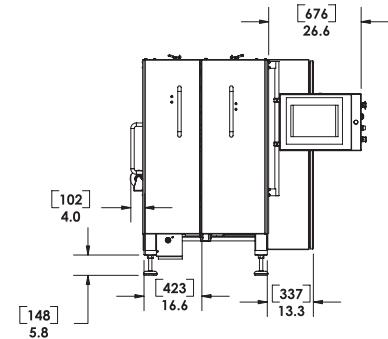

BOSCH

Invented for life

Packaging - Processing
Bid on Equipment
1-847-683-7720
www.bid-on-equipment.com