

## **FILABELMATIC**

**Fill and label simultaneously** is exactly what **FILABELMATIC** means.

There is an endless number of products that can be easily filled or labeled. Biner-Ellison realized the need for such a machine. Since 1936 B-E has built more than 1000 **FILABELMATICS**.

The engineers of B-E have constantly kept the Filabelmatic ahead of time. Consider the many modern features:

Fills and labels plastic container, glass and tin. Fills all free-flowing non-carbonated liquids. Applies spot, body and neck, three panel and wrap-around labels to glass, tin or plastic.

The **FILABELMATIC** has all methods of filling available—vacuum, vacuum-pressure, pressure, gravity and gravity-vacuum.

There are twelve models and sizes available. The **FILABELMATIC** offers strip glue, also sliding picker plates for over-all glue. Why buy two machines or setup two machines when one **FILABELMATIC** will do the job?

*This fine machine warrants your most careful consideration.*

*Packaging – Processing*

**Bid on Equipment**

1-847-683-7720

[www.bid-on-equipment.com](http://www.bid-on-equipment.com)

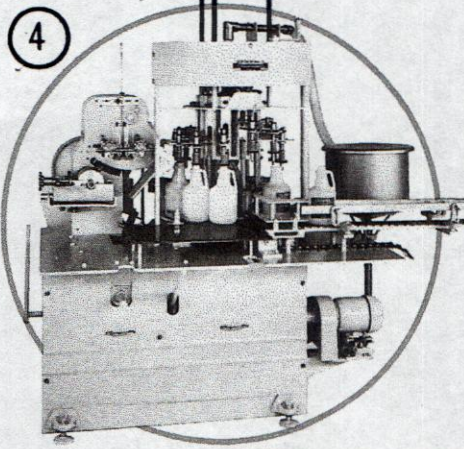

**SEMI-FILABELMATIC,  
 MODEL SFLA-26**

Containers are fed by hand but the simultaneous filling and labeling is automatic. 12 stations on quarts with speeds to 40 per minute. Six stations on gallons, speeds to 10 per minute. Automatic discharge optional.

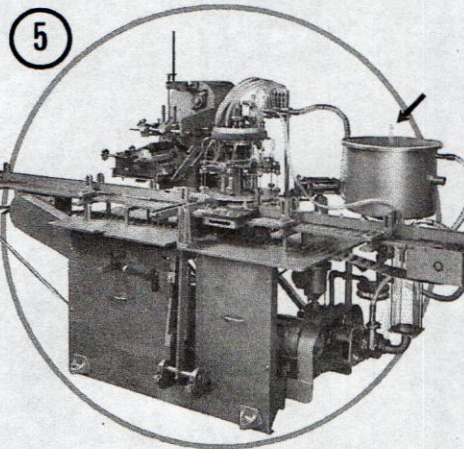
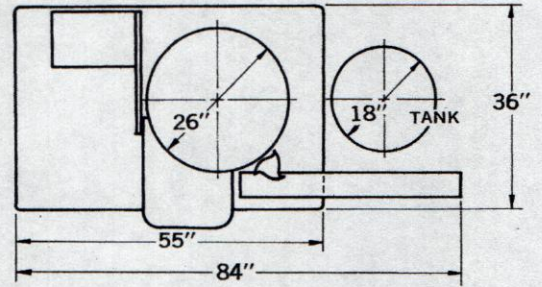

**MINIATURE FILABELMATIC,  
 MODEL FLE-16**

Automatic vacuum filling and labeling of small containers from fractional ounce to 8 ounces. Single model speeds to 60 per minute. Duplex model speeds to 100 per minute.

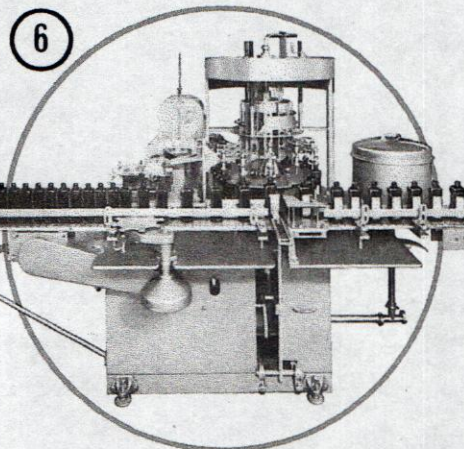
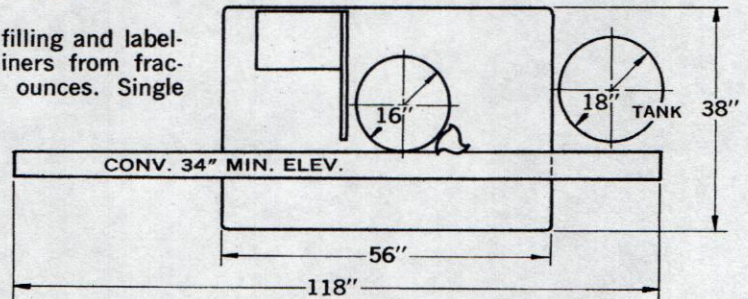

**FILABELMATIC, MODEL FLA-26**

This is the standard model of the FILABELMATIC LINE and the most versatile. Filling systems are available for all free-flowing, non-carbonated liquids. Labels most any size or shape container, glass, plastic or metal. Speeds to 60 per minute on standard 12-station model with gallons on 6 stations at 15 per minute. DUPLEX 24-station model speeds to 100.

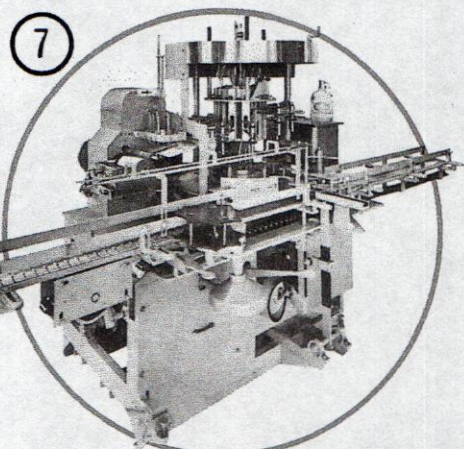
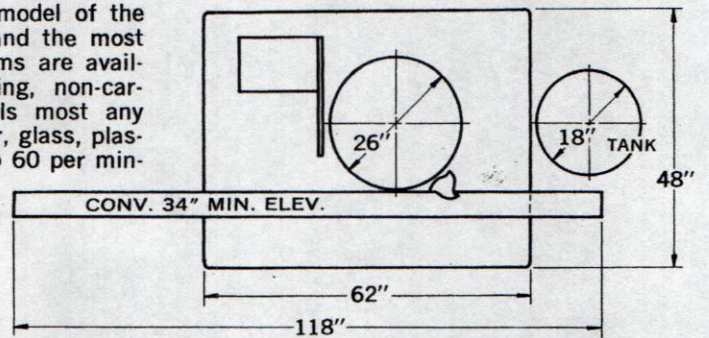

**FILABELMATIC, MODEL FLA-32**

The most popular "Jugging" machine available; can fill and label glass, plastic or metal gallon containers at 30 per minute, operating on 12 stations. Quarts can run DUPLEX up to 100 per minute.

