

BEMISTAPER

1018-B

Uniform Box Sealer
Bottom-Belt Design

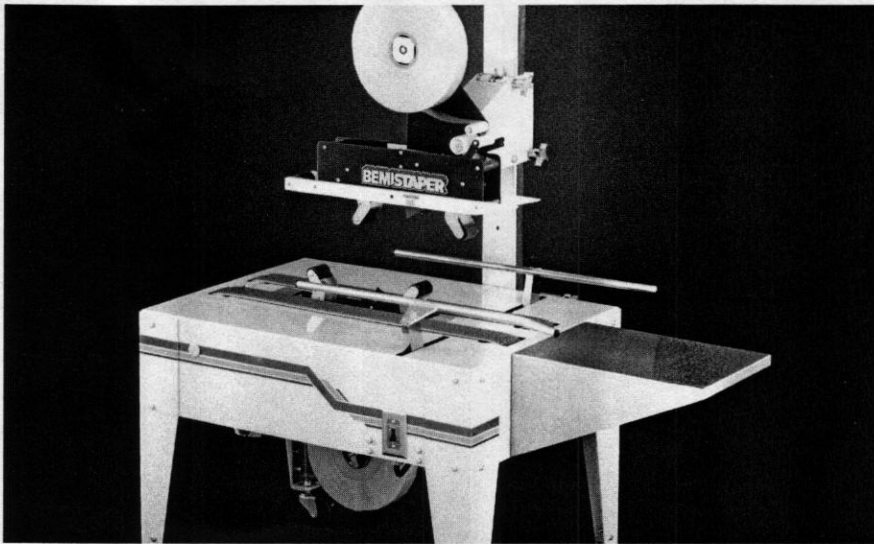

The BEMISTAPER 1018-B Uniform Taper is a bottom-belt machine that automatically applies

pressure-sensitive tape to both top and bottom of previously closed cases.

Now Available With
QUICK-opener™
and **Tension-Master™**
Taping Heads

Operation

The container is filled and closed. It is then manually fed onto the bottom belt feed, under the top guide rails, and between the box guides.

The belt-feed transports the container to the taping heads (or head) which apply the tape to the leading panel approximately 2" (51 mm) from the top and the

bottom. The tape is then applied to the top and bottom of the container and 2" (51 mm) along the trailing panel, both top and bottom. As the tape is applied, a series of 3 rollers on top and 2 on the bottom "buff" the tape to ensure its adhesion to the container.

Once the proper length has been dispensed, a spring-loaded serrated blade is released, cutting the tape. The cut end remains securely in place and is applied to the leading panel of the following container. As the container leaves the taping section, the rear pressure roller follows the trailing end of the container, applying the final compression to the tape.

Design Features

- Tension-Master™ tension control system. The Tension-Master taping head incorporates a constant tension roller and a pivoting knife arm — both to ensure consistent case sealing time after time.
- Uses polypropylene and other plastic film tape from 1½" to 2" (38 mm to 51 mm) wide.
- Completely electrical; plugs into any 115 volt outlet.
- Rugged, heavy steel construction for long life.
- Interchangeable tape applicators.
- Bottom applicator can be removed without tools; simply lift out to reload.
- Unique applicator positively holds "tail" of tape in position.
- Long life knives with effectively designed guards.
- Overload protection for electrical system.
- Cantilevered head mount for easy access to functional areas.
- Modular construction facilitates fast replacement of all worn components.
- Bottom-belt design provides maximum stability and positive transfer.
- Long lasting "grip top" belts provide positive traction for the container as it travels through the sealing process.
- Polyurethane rollers and belts.
- All moving parts have been sound dampened for quiet operation.
- Tape is compressed on the box 3 times to ensure a positive close.
- Adjustable tape tension for various gauge tapes.
- Can change sizes in seconds; no tools required.
- Made in the U.S.A. by Bemis and their Packaging Machinery Division, which has been designing and building innovative packaging machinery since 1930.
- Automatic adjustment for length of case.
- Three-year warranty on tape head and one-year warranty on entire machine.

BEMISTAPER 1018-B Uniform Box Sealer Bottom-Belt Design

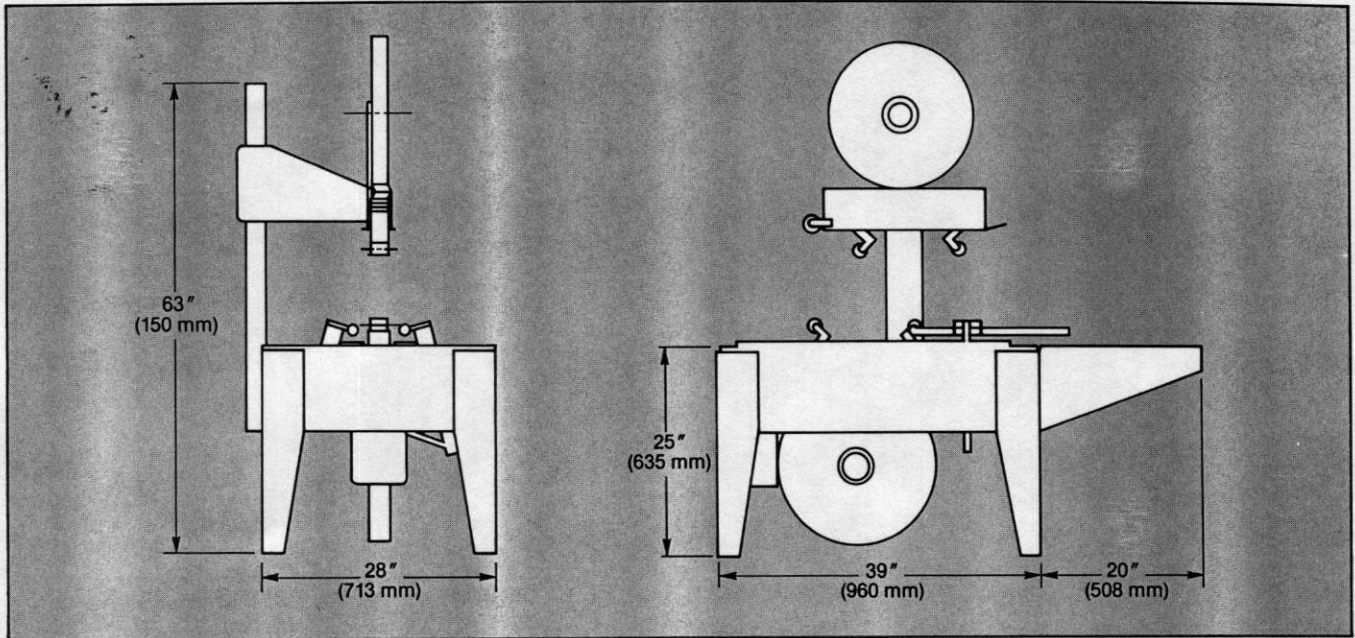

Specifications

OVERALL DIMENSIONS

Width: 32" (813 mm)
 Length w/o Frame Deck Extension: 46" (1168 mm)
 Length w/Frame Deck Extension: 59" (1500 mm)
 Height w/o Leg Extensions or Casters: 63¾" (1607 mm)
 Height w/Leg Extensions: 63¾" to 71¼" (1607 mm to 1810 mm)
 Height w/Casters: 66¾" to 74¾" (1695 mm to 1900 mm)

INFEED ELEVATION

W/o Casters and Leg Extensions: 25" (635 mm)
 W/Leg Extension: 25" to 33" (635 mm to 838 mm)
 W/Casters: 28½" to 36½" (724 mm to 927 mm)

POWER REQUIREMENTS

¼ HP General Purpose Motor,
 115 Volts, 1 Phase, 60 Hertz
 5.8 Amp Maximum Current Draw
 (input cord and plug provided)

CASE SIZE RANGE (STANDARD)

	MINIMUM	MAXIMUM
Length:	4½" (114 mm)	(No Limit)
Width:	4½" (114 mm)	20" (508 mm)
Depth:	4½" (114 mm)	20" (508 mm)

RECOMMENDED TAPE ROLL SIZE

Maximum Roll Dia.: 19" (483 mm)
 Roll Core Inside Dia.: 3" (76 mm)
 Maximum Tape Width: 2" (51 mm)
 Minimum Tape Width: 1½" (38 mm)

PRODUCTION SPEED

Totally dependent on container size and operator proficiency. Machine is set to operate at 60 lineal feet (18.3 m) per minute. Seals up to 26 12" cases per minute.

SHIPPING WEIGHT

W/o Options: 340 lbs. (150 kg)

Optional Parts

■ QUICK-opener™ pull-tab system applies a QUICK-opener pull tab to the leading panel of the box.

- Extended height capability.
- Pack assist tables — holds empty boxes in place.
- Stainless steel machine.
- Deck extension for infeed side of taper — 14" wide x 20" long (356 mm x 508 mm).
- Leg extensions — from 2" to 8" (51 mm to 203 mm).

- Locking type casters (include leg extensions for mounting).
- Side pressure rollers — control gap between top major flaps.

Machine photograph shows optional equipment. All illustrations and specifications are subject to change without notice and any drawing dimensions are not to scale and are approximate. Machines shown without guards are for illustrative purposes only. Guards are supplied and must be in place before operation. All sales are subject to our prevailing terms and conditions of sale.

The Packaging Specialists



The Bemis Company
 Distributor Products Division
 P.O. Box 2968, Oshkosh, WI 54903-2968
 800-328-4550

Packaging - Processing
Bid on Equipment

1-847-683-7720

www.bid-on-equipment.com