



The worldwide leader in donut production equipment

+1.206.322.5474 • info@belshaw.com • www.belshaw.com



FROZEN DONUT PROCESSING WITH THERMOGLAZE

Models: Thermoglaze 25 / Thermoglaze 50

Belshaw's Thermoglaze system provides the method for thawing, heating and glazing pre-fried, frozen donuts and baked goods that bakers have been looking for.

The Thermoglaze system successfully addresses a common complaint with frozen donuts — stale taste and poor shelf-life after thawing. Frozen donuts that are reconstituted using the Thermoglaze system have greater moisture content and longer shelf-life than those thawed in air. In fact, donuts produced on the Thermoglaze system approach, and can surpass, the quality of fresh made donuts.

The Thermoglaze system consists of two components — the Thermolizer, for thawing frozen baked goods, and the Thermoglaze, for heating and glazing. Donuts can be held in the Thermolizer for up to five hours, allowing your bakery to supply hot, fresh-tasting donuts to your customers with little wait — or fuss.

The Thermoglaze system does not require a ventilation hood, does not utilize shortening, and improves glaze yield — reducing both set-up costs and operating costs.



Thermoglaze 25 (rear view, with Thermolizer on right, configuration 'B')



Thermoglaze 50 with Thermolizer TZ-6 (right) and TZ-17 (left)

BELSHAW BROTHERS, INC • 814 44th St NW, Suite 103, Auburn, WA 98001 • USA
Tel +1.206.322.5474 • Fax +1.206.322.5425 • Email info@belshaw.com • www.belshaw.com

©2009 Belshaw Adamatic Bakery Group • Product specifications may be changed without notice.

Packaging - Processing
Bid on Equipment
1-847-683-7720
www.bid-on-equipment.com



Thermoglaze System

Thermoglaze Standard Features

- One-switch operation.
- Unique conveyor design which greatly reduces donut handling.
- No ventilation hood or fire suppression system required.

***PATENTS PENDING**

Thermolizer Standard Features

- Regulated moisture and temperature for maintenance of donut quality.
- TG-25 features an integrated Thermolizer unit
- TZ-6 (6 shelves) rolls under TG-50 to form a compact unit.
- TZ-17 (17 shelves) stands separately and is mobile.

Thermolizer Options

- Auto-water feed (TZ-6 and TZ-17 only)
- Glazing screens for TG-50 system:
 - 17" x 25" (Belshaw #SL200-4)
 - TZ-6 - 36 screens recommended
 - TZ-17 - 72 screens recommended
- Glazing screens for TG-25:
 - 12.5" x 17" (Belshaw #TJ-0001)
 - 36 screens recommended



All Thermoglaze components conform to UL-197, CSA C22.2, and NSF-4.
TG-25 also conforms to NSF-8.

TG-50

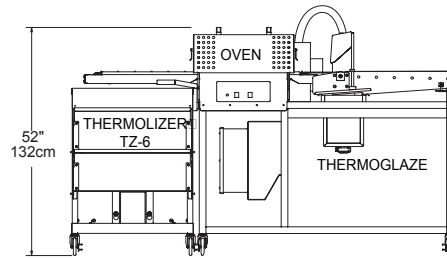
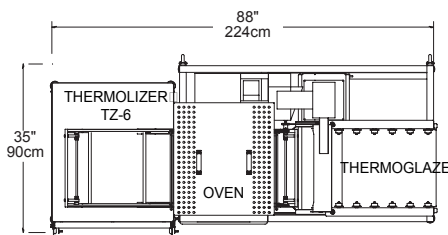

TG-25

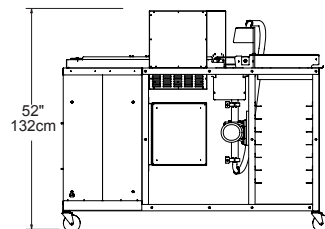
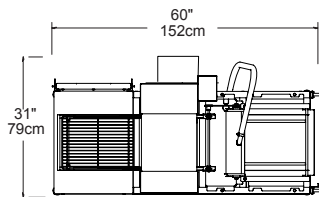

TZ-17

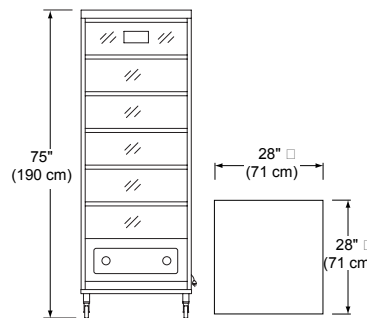

TG-25 Product Flow Diagrams

FLOW = THERMOLIZER → OVEN → GLAZER

The TG-25 can be specified with product flow in either direction. In addition, Thermolizer can be specified to operate either from the FRONT or BACK.

When purchasing specify TG-25 configuration as A, B, C or D as follows:

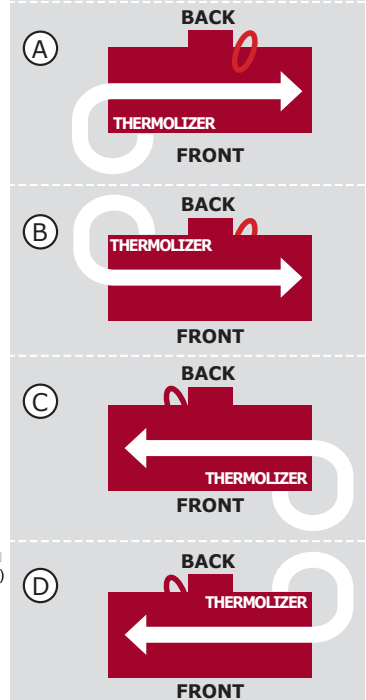

Dimensions And Power

MODEL	CAPACITY	APPROX. DIMENSIONS & WEIGHT				POWER REQUIREMENTS		
		WIDTH	DEPTH	HEIGHT	SHIP WEIGHT	VOLTS	AMPS	KW
THERMOGLAZE (TG-25)	25 doz/hr	60in (152cm)	31in (79cm)	52in (132cm)	475 lbs (216 kg)	208-240V/60/1	28 A ²	6.7 KW
THERMOGLAZE (TG-50)	50 doz/hr	88in (214cm) ¹	35in (87cm)	52in (132cm)	650 lbs (295 kg)	208-240V/60/1	33 A ³	6.7 KW
THERMOLIZER (TZ-6)	50 doz/hr	29 in (74cm)	34 in (87cm)	38 in (97cm)	250 lbs (114 kg)	208-240V/60/1	13 A	3.1 KW
THERMOLIZER (TZ-17)	68 doz/hr	29 in (74cm)	35 in (89cm)	76 in (192cm)	300lbs (136 kg)	208-240V/60/1	20 A	4.6 KW

IMPORTANT: 1 Includes TZ-6 Thermolizer as shown in drawing above. Separate space needed for TZ-17 Thermolizer if used
2 Includes integrated Thermolizer.

3 Does not include Thermolizer. TZ-6 may be plugged into TG-50; for current on TG-50 circuit, TZ-6 must be added to the TG-50.

PLUG TYPES: TG-50 and TG-25: plug type NEMA #6-50P. Cord length: 72in (1.8m).

TZ-6: plug type NEMA #6-20P. Cord length: 72in (1.8m). Plug inserts to TG-50.

TZ-17: plug type NEMA #6-30P. Cord: 72in (1.8m). Does not insert to TG-50.

BELSHAW BROTHERS, INC • 814 44th St NW, Suite 103, Auburn, WA 98001 • USA

Tel +1.206.322.5474 • Fax +1.206.322.5425 • Email info@belshaw.com • www.belshaw.com

©2009 Belshaw Adamatic Bakery Group • Product specifications may be changed without notice.

Packaging - Processing

Bid on Equipment

1-847-683-7720

www.bid-on-equipment.com