



The worldwide leader in donut production equipment

+1.206.322.5474 • info@belshaw.com • www.belshaw.com



HIGH PRODUCTION ICERS

HI-18C (Countertop)

HI-18F (Floor model)

HI-24 (Floor model)

Belshaw's HI-series Icers provide fast, uniform icing of cake and yeast-raised donuts - and any product under 2 inches in height - all without the need for the operator's hands to touch the product or icing.

Full screens or bun pans can be iced in seconds. Special skills are not needed - consistent, uniform icing can be applied by a novice. Easy changeover to different flavors is accomplished by removable, heated icing pans stored under the icing unit.

The **HI-18** icer accommodates 18" x 26" standard screens or bun pans. The **HI-24F** accommodates all sizes up to 24" x 26" screens or pans. Floor models occupy little space and are moveable on casters. The **HI-18C** is designed for countertop use.

Icing is held in a large capacity trough and warmed indirectly by a low wattage, uniform radiant heating system. Belshaw's unique donut handling system delivers the donuts to the icing and retrieves uniform, smudge-free finished products, without immersing the screen or bun pan. The finished product is immediately ready for display.

Heavy-duty construction and sound design facilitate cleaning and provide a durable product that will stand up to years of everyday use.



Belshaw HI-18C Countertop Icer



Belshaw HI-18F Floor Model Icer



Belshaw HI-24F Floor Model Icer

BELSHAW BROTHERS, INC • 814 44th St NW, Suite 103, Auburn, WA 98001 • USA

Tel +1.206.322.5474 • Fax +1.206.322.5425 • Email info@belshaw.com • www.belshaw.com

©2009 Belshaw Adamatic Bakery Group • Product specifications may be changed without notice.

Packaging - Processing
Bid on Equipment
1-847-683-7720
www.bid-on-equipment.com



HI-18C (Countertop)

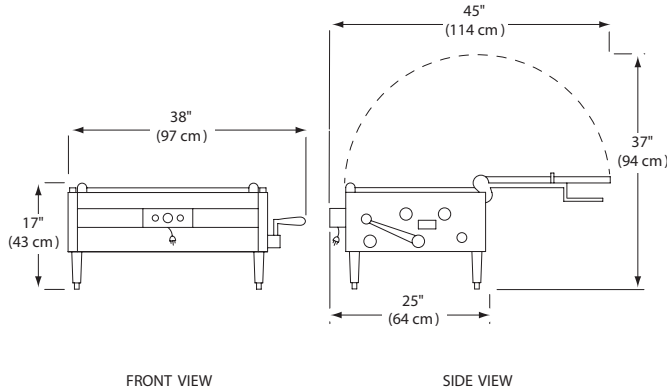

Standard Features

- NSF listed
- Heavy duty construction of stainless steel, aluminum alloys, and plated steel.
- Easily removable icing pan for quick changeover to other flavor icings.
- Storage space within floor models for 4 additional icing pans
- Infinite range thermostat control.
- 4 casters, 2 lockable (floor models only).
- Removable components for easy cleaning.
- Cleanable in rack washer, after removing heating unit.
- HI-18C/HI-18F certified NSF-2
- HI-24F no certification

HI-18F • HI-24F (Floor Models)

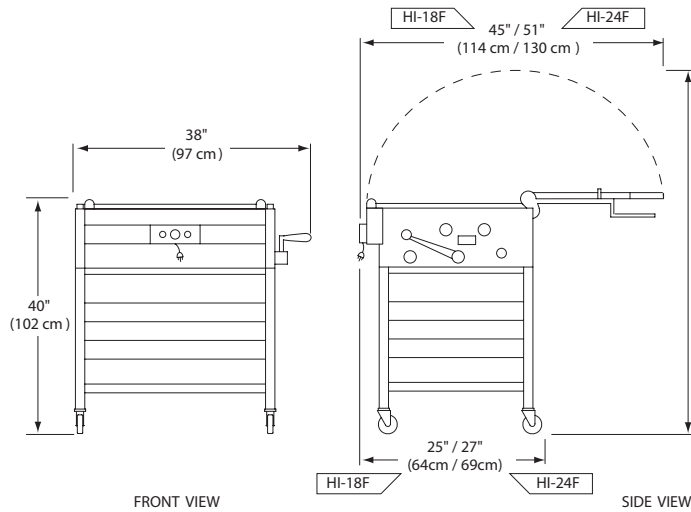

Screen Sizes And Capacity

Model	Max screen / bun pan size		Icing capacity		Number of donuts (typical)
	in	cm	lbs	kg	
HI-18C	18 x 26	46 x 66	50	23	24
HI-18F	18 x 26	46 x 66	50	23	24
HI-24	23 x 23	58 x 58	60	27	36



HI-18C/HI-18F only
NSF Std 2

Dimensions And Power

Model	L x W x H		APPROX. SHIP. WT.		120 V		208/240 V	
	in	cm	lbs	kg	W	A	W	A
HI-18C	38 x 45 x 17	97 x 114 x 43	220	100	900	7.5	780/1000	3.8/4.3
HI-18F	38 x 45 x 40	97 x 114 x 102	325	148	900	7.5	780/1000	3.8/4.3
HI-24F	38 x 51 x 40	97 x 130 x 102	394	179	1200	10	1100/1300	5.0 5.7