

*Belshaw*

# **DOMIX 45**

**Water Doser Mixer**

**Operator's Manual**

**CODE 2600124 – 10.09.2001**

Belshaw Bros., Inc.  
1750 22<sup>nd</sup> Ave S.  
Seattle, WA 98144  
Phone: 206-322-5474  
Fax: 206-322-5425  
Toll Free: 1-800-578-2547  
E-mail: [service@belshaw.com](mailto:service@belshaw.com)  
<http://www.belshaw.com>

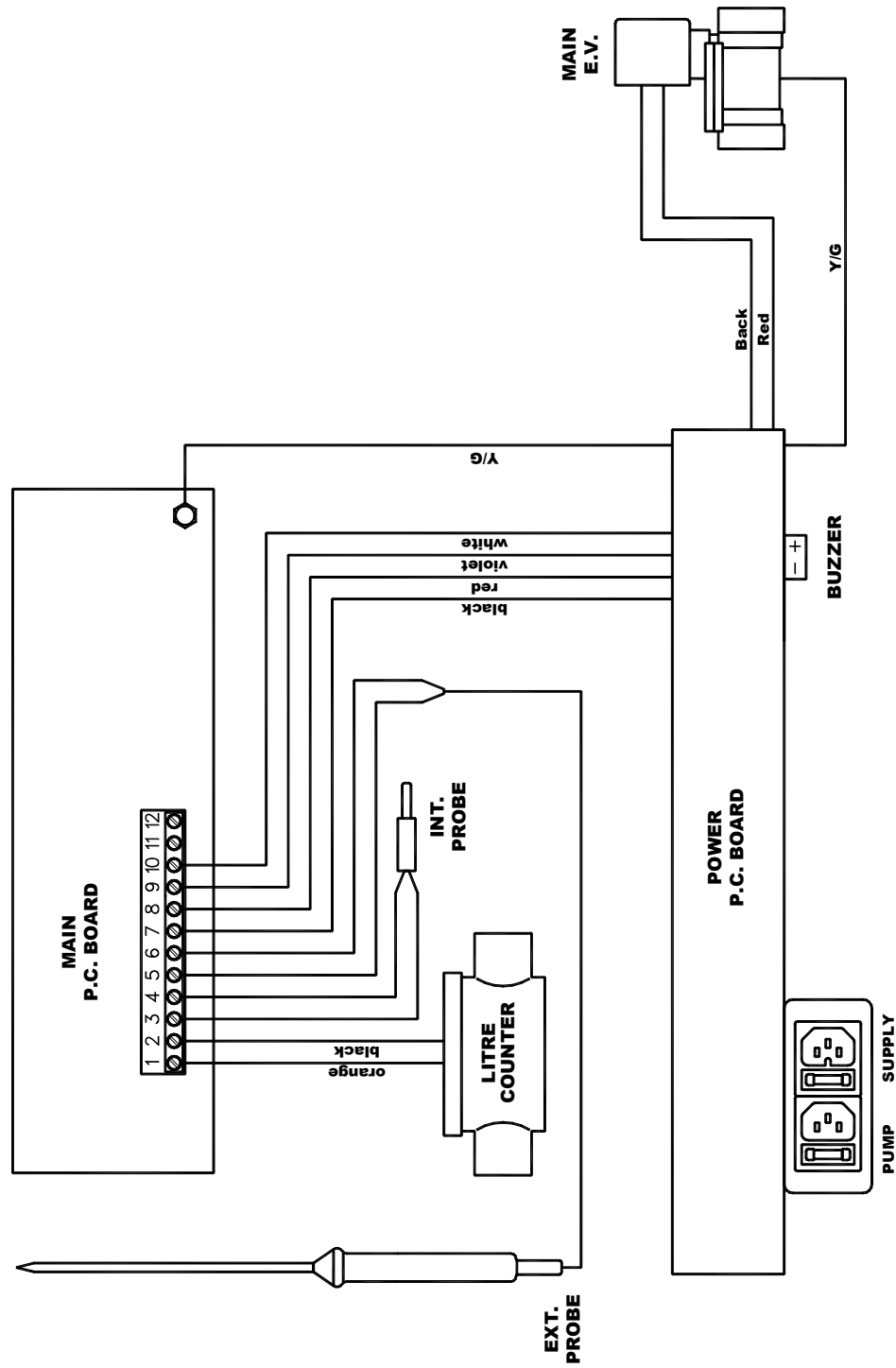

Figure – 1: Wiring diagram

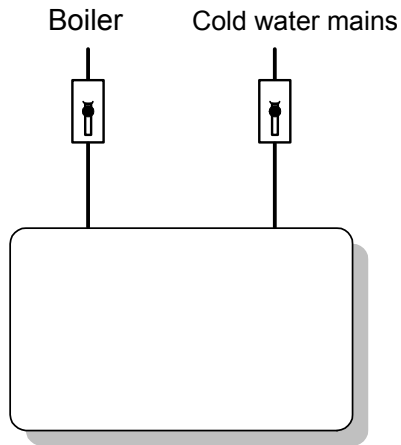

Figure 2

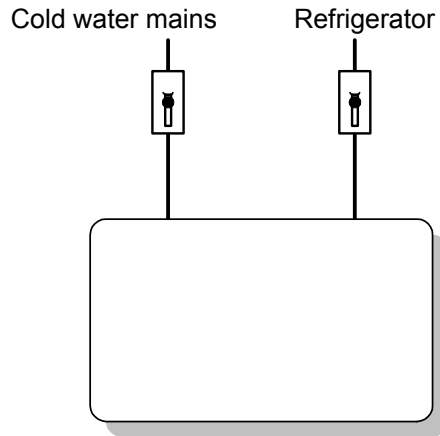

Figure 3

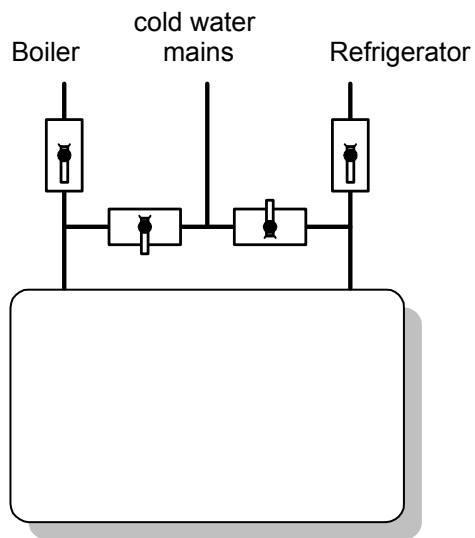

Figure 4

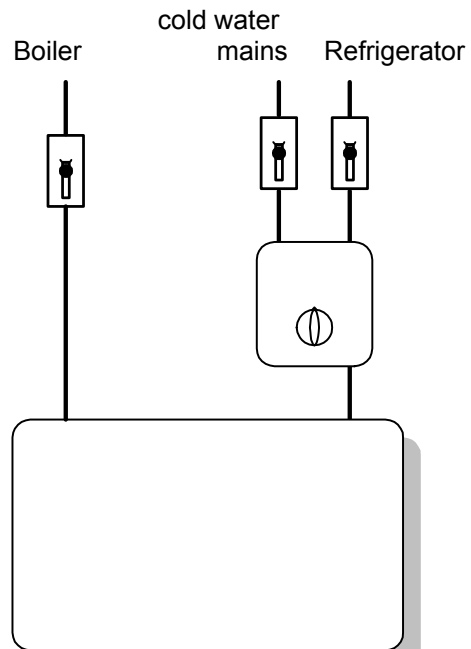

Figure 5

Figure 1 and 2: standard machine – Figure 3: with manual feeding kit  
 Figure 4: with automatic feeding kit

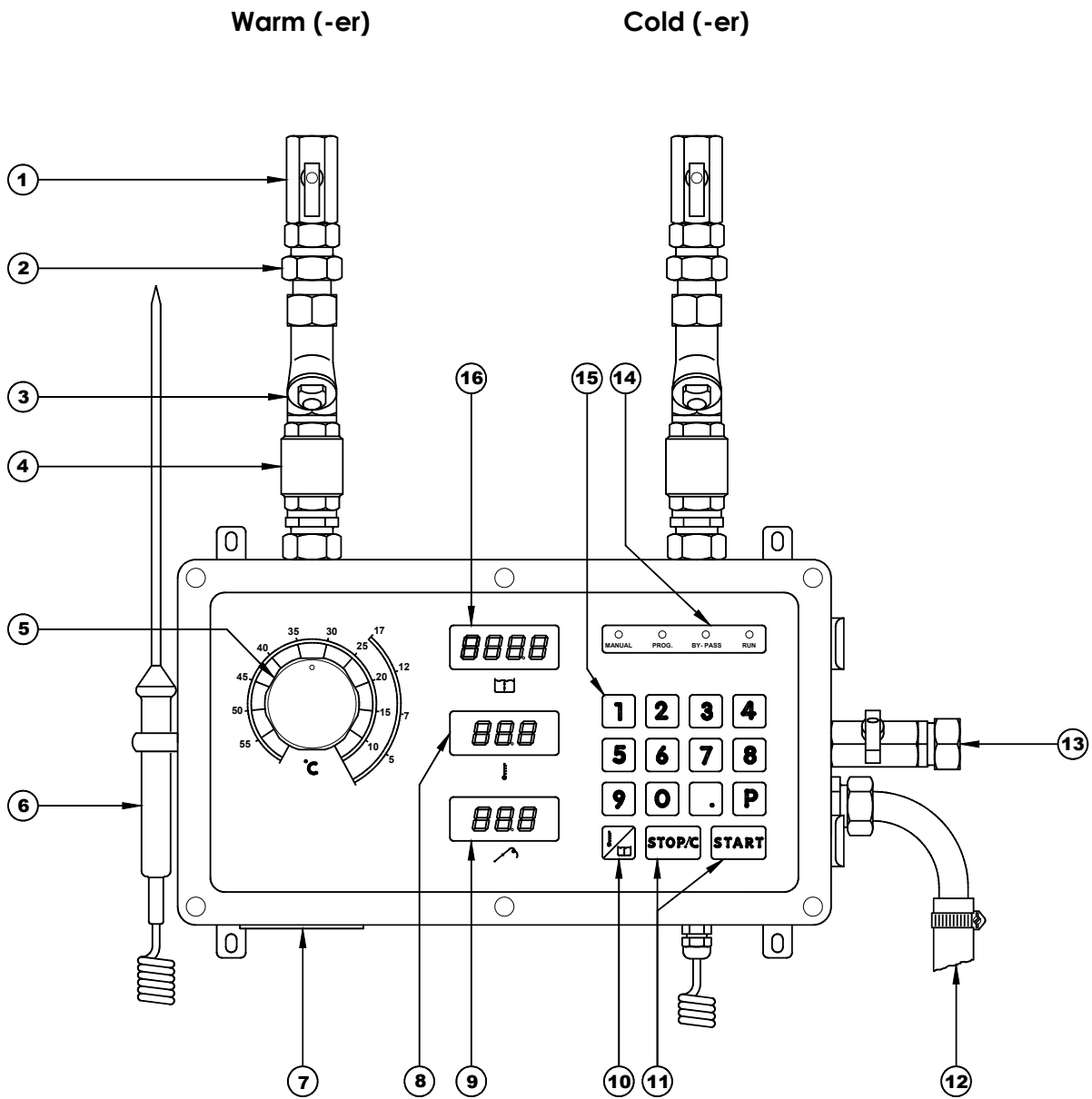

Figure – 6: machine overview

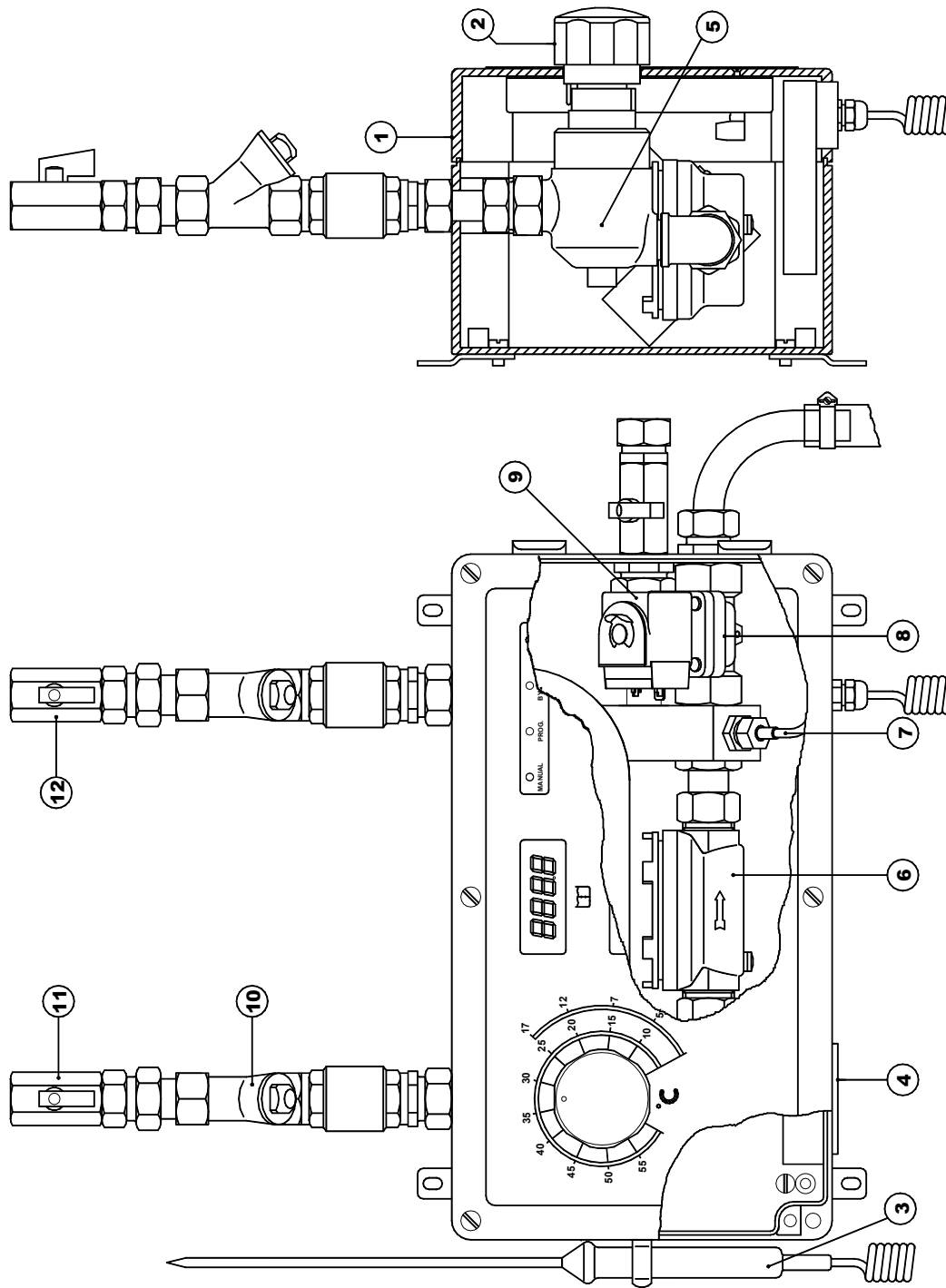



Figure – 7: Spare Parts

## 1. DESCRIPTION

(see figure no. 6 page 3)

1. Ball gate valves
2. Unions for alternate installation
3. Double stainless-steel mesh water filters
4. Check valves
5. Temperature dial
6. External temperature probe
7. Electrical supply plug / remote control plug
8. Electronic thermometer display
9. Electronic thermometer display for external probe
10.  key toggles between temperature and volume displays
11. **STOP/C** (manual stop/clear memory) and **START** (starts water delivery) keys
12. 8'-0" delivery hose with stainless steel terminals
13. By-pass connection
14. Function control lights
15. Data entry keyboard
16. Digital display for water volume selected, or already delivered (after pressing **STOP**).

### 1.1 TECHNICAL FEATURES

SOFTWARE Version: DOMIX45.02I

The Domix 45 features are listed in the Table 1.

Supply tension (see equipment rating plate)	230Volt A.C. or 110Volt A.C. $\pm$ 10%
Frequency	50/60Hz
Power	25VA
Hydraulic connections	1/2"
By-pass water outlet	16mm
Max. inlet water temperature	150°F
Inlet water pressures	max.: 75 psi min.: 15 psi Max. pressure ratio between the 2 inlets: 1:5
Temperature control	Setting range 40 – 120°F Measure precision: $\pm$ 0.5°F Mixing precision: $\pm$ 1.5°F
Dosing control	Max. dosage quantity: 99 lb 15 oz. Min. dosage quantity: 1 oz Precision: $\pm$ 1% (over 1 lb)
Water delivery	at 15 psi and 70°F: 40 lbs/min at 75 psi and 70°F: 90 lbs/min
Supply fuse	5x20 mm, F 315 mA L 250 V for 230VAC 5x20 mm, T 630 mA L250 V for 110VAC
Pump remote control fuse	5x20 mm, F 6.3 A L 250V for 230VAC 5x20 mm, F 10 A L250V for 110VAC

Table 1

## 2. INSTALLATION

- In case of hard water (with high lime scale content = hardness in French degrees higher than 25 – 30, or 250 – 300 ppm) it is necessary to employ an ion exchange water softener. This unit must be calibrated so as to maintain a residual hardness ranging between 5 and 10 French degrees (50 – 100 ppm). The use of electronic water softeners is not advised, since their efficacy has not yet been proved.
- Fix the doser-mixer on the wall at a height from the floor of 4'4" – 5'1", using the four wall plugs supplied. The 90° wall plug hook is supplied to provide support for the water delivery outlet elbow.

### **Do not place other machines directly below the DOSER – MIXER.**

- Arrange the water inlet tubing as shown in the lay-out diagrams, figures 2 – 3 – 4 – 5, mounting the ball gate valves (1) at the end of the pipes (black lever = cold on the right and red lever = warm on the left).
- With reference to the figure 4, it is advisable to use the pre-assembled group: Three way connection kit, code 3801205.
- With reference to the fig 5, the use of Automatic kit is foreseen, code 3801231 (230V).
- Connect ball gate valves to the doser-mixer by means of the "O" ring gasket type unions (2).

- Insert the delivery hose (12) into its housing.
- Connect the by-pass (13) to a drain by means of a copper pipe with ½" internal diameter.
- Connect to the proper power supply (see equipment rating plate near the plug 7), single phase 50 or 60Hz, using the supplied socket, fitted with a three core cable min. section 3x1mm. An external switch is helpful.
- For the eventual pump remote control, use the supplied socket to connect the remote control switch of the pump(s). The use of such a pump is necessary when one of the two inlet pressures is less than 1 bar, for example when using unpressurized water heaters or refrigerators.

The plug on the device has the following wiring diagram (clean contact):

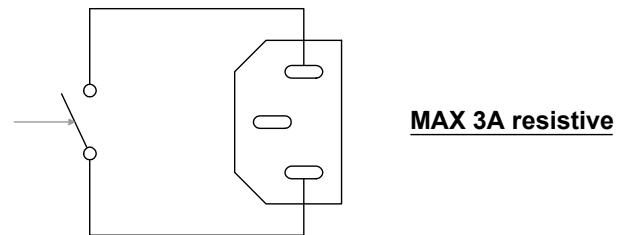



Figure – 8

### 3. OPERATING INSTRUCTIONS

Switch on the doser-mixer using the external switch (or by plugging in the socket).

The first displays appearing after switching on refer to the self-test. The displays show the numbers from 0 to 9, the microprocessor software version, then the data regarding the last discharge.

#### 3.1 MANUAL OPERATION

- Press **P00** on the keyboard (the yellow Manual led lights up and the decimal point of the liters flashes), then select the required water quantity. If only the quantity has to be stored, press **START**. If the operator also needs to store the temperature, press the  key: the flashing moves to the decimal point of the temperature, which can be set.

In case of error, in the liters or in the temperature, press the **STOP/C** key and reselect.

- Press the **START** key: the display (8) shows the actual discharge temperature and the display (16) indicates the decreasing liters.
- To manually stop water delivery at any time press the **STOP/C** key. In the display (16) the quantity of delivered water flashes; to resume the dosage, press again the **START** key; otherwise pressing again the **STOP/C** key the memory is cancelled and a different quantity can be set.
- Adjust the water temperature using the knob (5), checking it on the electronic thermometer (8). In case of correction, wait a few seconds before intervening, so as to allow the temperature to stabilize.
- To obtain the same water dosage in successive operations, simply press the **START** key, as the doser-mixer is provided with a memory. In the case of power failure during dosing the data is not lost; when power is restored simply repress the **START**

key to complete the dosing operation (see page 20 par. 3.5.3).

- To modify quantity and/or temperature in memory, press directly the  key and proceed as for the first data entry.
- To ensure optimum operation the warm water temperature must be at least 10°C higher than the required delivery water temperature and the cold water should be at least 3°C lower. Low temperatures (under 10° - 15°C) may be obtained only using a refrigerator.
- The doser-mixer is equipped with a valve for manual delivery of pre-mixed water (by-pass). This valve can be used both for discharging possible backwater in the pipes, when the doser is switched on for the first time every day, and for water delivery during power failure or in the event of dosing solenoid valve failure.

#### NOTES:

- 1) The by-pass function light never switches on in this machine version, and the RUN function light is on during the whole discharge.
- 2) The stored temperature appears only when a recipe is recalled, or when the key for the quick modification is pressed, and remains for 6"; then the  display shows the actual internal probe temperature.

#### 3.2 OPERATION WITH 80 PROGRAMS

##### 3.2.1 Initial recipes setting

Set the program number (ex. **P01**, **P02** etc.) appearing on the lower display (9) (**PROGR.** lights up) and then the desired water quantity, appearing on the upper display (16).

To store the temperature also, press the  key and proceed as for manual operation.

It is possible to exit from a recipe setting dosing the recipe itself (press **START**), setting a new

recipe (press **P...**), or automatically after 10 seconds: in all these cases the recipe is stored.

**Warning:** recipe numbers from 1 to 9 must always be set using the format: 01, 02, etc..

### 3.2.2 With recipes already programmed:

To recall a recipe, enter the desired number (for example **P28**), which is shown for 3 seconds on the lower display (9), while the upper displays show the relevant quantity and temperature.

Press **START** to carry out the dosing.

If modifications are required, set the new quantity and/or temperature as explained above.

To stop water delivery manually at any time press the **STOP/C** key. After that on the display (16) the delivered water quantity flashes; to resume dosing press again the **START** key, otherwise, pressing the **STOP/C** key, the quantity is cleared and it is possible to set a new quantity.

### 3.3 USE OF EXTERNAL PROBE

The equipment is fitted with an auxiliary precision electronic thermometer with a mobile probe (6), usable at distances up to 5 metres.

Temperature readout on the display is continuous (9), except when the program number appears.

### 3.4 SPECIAL FUNCTIONS

- Press the **P** key twice, and the device shows the succession of the recipes stored in memory.
- Holding the  key for 10 seconds, the total amount of m<sup>3</sup> delivered by the machine (with a decimal number) is indicated: see example in Figure 9.

2 4 5. 7

t o t

M E M

Figure -9

By pressing the **STOP/C** key, a number will appear. This is the number of times divided into 10, that the electrovalve has been opened (see fig. 10).

E L. U

2 0 3

Figure -10

Pressing again the **STOP/C** key, the normal visualization is restored.

**NOTE:** The totalizers will automatically go to zero when they reach 999.9m<sup>3</sup> and 9990 times respectively (visualized: 999).

- To prevent modification of the recipes, it is possible to protect the setting and modification operations, press the **P** key for 5"; the display indicates the wording as in Figure 11, in which the code 147 has to be entered.

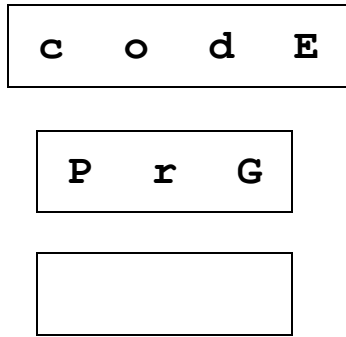

Figure -11

Then, press the **P** key and the display indicates the wording as in Figure 12:

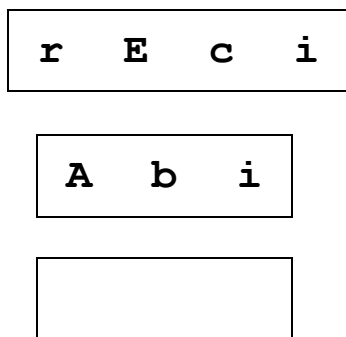

Figure -12

Press the **1** key, and the wording **diS** appears, indicating that the recipe programming is disabled; press the **2** key, and the wording **Abi** appears, indicating that the recipe programming is enabled.

Press **P**, and the normal visualization is restored.

- Free delivery: it is possible to exclude the liter-counter counting (for example in case of malfunction of the part) by means of the special program **P99**:

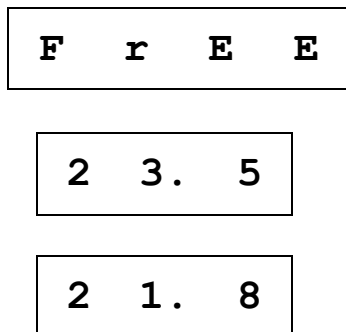

Figure -13

With the **START** and **STOP** keys the electrovalve opens and closes.

### 3.5 ERROR MESSAGES AND CORRECTIVE ACTIONS

All error messages are accompanied by flashing words and an intermittent acoustic signal. The latter can be stopped with the **STOP** key. Using the **START** key, the error message is cancelled and the delivery starts again. However, pressing the **STOP** command twice cancels the delivery. The possible error messages and relevant wordings are listed below.

#### 3.5.1 Quantity counting error

After pressing **START**, this wording appears after 12 seconds:

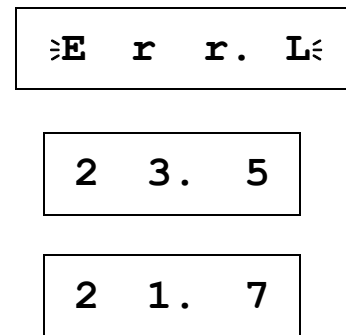

Figure -14

#### Possible causes:

- If no water comes out of the device:
  - The cocks on the inlets of warm water and/or cold water are not open. Check that both are open and that the connection to the pipes is correct.
  - The inlet filters are obstructed. Clean them.
  - The electrovalve does not open. Contact the Service.
- If water comes out normally and this message appears, it indicates a malfunction of the liter-counter. Contact the Service.

#### 3.5.2 Probe error

The **PrE** wording appears on the display referred to the damaged or wrongly connected probe.

Contact the Service for the replacement. In the meantime, if the internal probe is broken, use the external probe to check that the temperature is correct.

### 3.5.3 Tension fall

If there is a tension fall during a water delivery, the device stores the delivered quantity and interrupts the delivery. When tension is restored, the following wording appears:

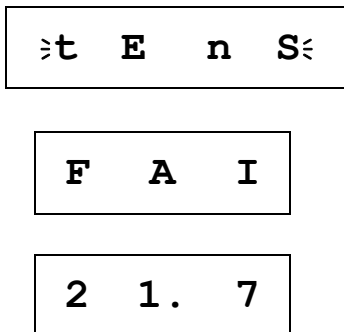

Figure -15

Press **START** to complete the dosage.

### 3.5.4 Parameter error

If, after switching the machine on, the following message appears on the display:

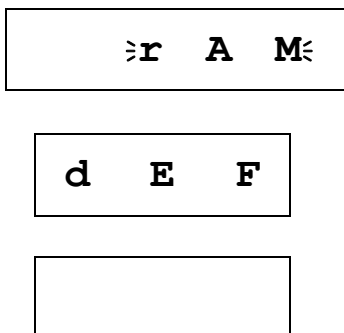

Figure -16

some incongruous values have been found in the machine parameters.

For further information contact the Service.

However, it is possible to restart the machine with the standard settings:

- Press simultaneously the keys 2 and 6 for 5 seconds: the device restores the default values and restarts automatically. While holding the keys, the display shows the menu of figure 17 and indicates that the standard values are being setting (manual by-pass).

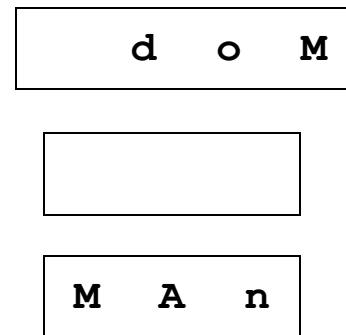

Figure -17

### 3.6 OPERATION INTERRUPTION

If, with tension available, all displays remain off, it means that electrical supply does not reach the main board, or the main board is damaged.

#### Possible causes:

- Over-tension and/or supply fuse failure. Open the fuse housing next to the supply plug, take out the spare fuse and replace the damaged one.
- Damage to the actuators board or the main board. Contact the Service.

## 4. MAINTENANCE INSTRUCTIONS

To assure a long working life of the internal parts of the device, the following periodic checks are necessary:

1. Clean the filters (3) regularly, particularly if the water contains a high quantity of lime-scale.
2. When switching off the doser-mixer, always set the temperature regulation knob (5) to its mid position, to allow a minimum number of moves in the mixer valve, particularly when

deliveries at the same temperature are carried out.

3. To clean the external surface of the doser-mixer, use a soft sponge and water or a neutral detergent; for more resistant grime, use alcohol or turpentine.

### 4.1 SPARE PARTS

Figure-7 on page 4 shows the machine overview indicating the various components of the device and, Table 2 (below) lists their description with relevant spare parts code numbers.

POS.	DESCRIPTION	CODE - 230V	VARIANTS - 110V
1	Cover with keyboard and electronics	3811046	---
2	Regulation knob	3801208	---
3	External temperature probe	3812511	---
4	Actuators and supply board	3811549	3811537
5	Thermostatic element	4400351	---
6	2 wire liter-counter	3801007	---
7	Internal temperature probe	3812522	---
8	Electrovalve assembly with coil	3801127	3801129
9	Coil for electrovalve	4400405	4400406
10	Filter – no return valve assembly	3801230	---
11	Hot water ball gate valve (red, left)	3801216	---
12	Cold water ball gate valve (black, right)	3801217	---
---	Internal electrovalve group	4400451	---
---	Supply flying socket	4400606	---
---	Pump remote control flying socket	4400608	---
---	Delivery Hose Ø 16mm	3801209	---

Table 2