



The worldwide leader in donut production equipment

+1.206.322.5474 • info@belshaw.com • www.belshaw.com



## ELECTRIC FRYERS (Floor Model)

Models: 618L • 624 • 634  
(Floor Model, Electric)

Belshaw's 600-series electric heated open kettle fryers are designed to produce high quality donuts with low operating costs.

The heavy duty elements used by the 600 series are robust enough to withstand daily use for the entire life of the fryer. Space under the elements is reserved as a cool zone to avoid further heating of frying debris. The elements themselves tilt up to vertical to allow quicker cleaning after each shift. The kettle can be quickly removed for periodic cleaning outside the fryer.

Easy-to-use submerger screens can be added to further improve production efficiency. And Belshaw's 600-series open kettle fryers also accommodate the EZ Melt under-kettle shortening melter/filter. The EZ Melt can melt a block of shortening, and pump new shortening directly to the fryer at the touch of a foot pedal.

600 series fryers are fully compatible with Belshaw Type 'B' and Type 'F' donut depositors. Belshaw provides a full line of complementary equipment that saves labor cost and improves quality consistency:

- EP18-24 Proofing Cabinet
- Type 'B' and Type 'F' cake donut depositors
- EZ Melt Shortening Melter-Filter
- SF Shortening Filter
- HI24 Production Icers
- H&I 2-4 Icing Tables
- HG, HGEZ Hand Glazers

### Products made commercially using floor model electric fryers:

- Donuts
- Hushpuppies
- Funnel cakes
- Elephant ears
- Fried pies
- Loukoumathes, philafels
- Paczkis, porogis
- Beignets
- Fritters, fried dough
- Crab cakes, clam strips
- Fried corn
- Fried vegetables
- + More fried goods of all kinds



Belshaw 624 Electric Fryer (with Type 'B' donut depositor and submerger)



618L electric fryer (18" x 26")



624 electric fryer (24" x 24")



634 electric fryer (34" x 24")



Frying screen (identical to proofing screen, but has bolt-on handles). Screens are reinforced wire mesh, spaced 1/4" (6mm) apart, manufactured from nickel-plated steel.



Screen cradle and proofing screen. The best way to transfer raised donuts from proofer to fryer.



Detachable handles and proofing screen. For cake or raised donuts.



**Standard Features**

- Stainless steel tank, cabinet, and drain tray (specify whether drain tray should be on left or right side when ordering)
- Heavy duty elements, tiltable upwards for easy kettle cleanup
- 2 nickel plated cake donut frying screens with bolt-on heat dissipating handles
- Adjustable, bolt down legs
- Exterior drain valve control

**Options**

- Extra frying/proofing screens (fixed or detachable handles optional)
- Screen cradle - (enables easy screen usage without any need for handles)
- Submerger

**600 Series Fryers - Capacity Chart**

(Dozen donuts/hour @ 90-second frying time. Production will vary depending on product size, shortening temperature and composition of donut)

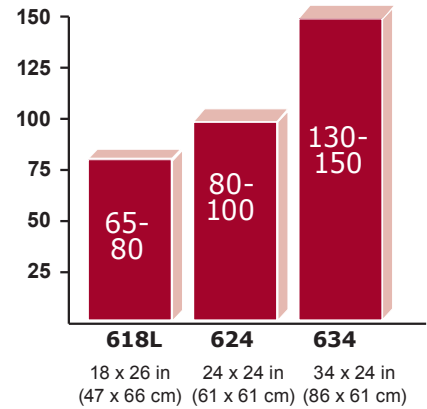

**618L/624/634 Fryers**

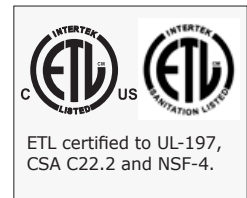
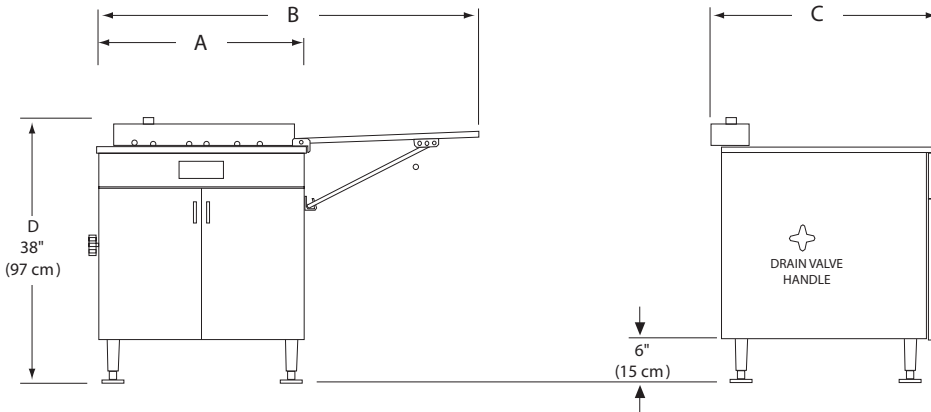

**Dimensions**

| MODEL | A            | B           | C          | D          | FRYING AREA             | SHORTENING CAPACITY | APPROX. SHIPPING WEIGHT |
|-------|--------------|-------------|------------|------------|-------------------------|---------------------|-------------------------|
|       | Width closed | Width open  | Depth      | Height     | Width x Depth           |                     |                         |
| 618L  | 28" (71cm)   | 48" (122cm) | 37" (94cm) | 38" (97cm) | 18" x 26" (46cm x 66cm) | 83lbs (38kg)        | 240 lbs (110 kg)        |
| 624   | 34" (86cm)   | 59" (150cm) | 35" (89cm) | 38" (97cm) | 24" x 24" (61cm x 61cm) | 97lbs (44kg)        | 260 lbs (118 kg)        |
| 634   | 44" (112cm)  | 77" (196cm) | 35" (89cm) | 38" (97cm) | 34" x 24" (86cm x 61cm) | 138lbs (63kg)       | 385 lbs (175 kg)        |

**Energy Requirements**

| MODEL | 208/240V 1ph |        | 208/240V 3ph |       | 380/415V 3ph |       |
|-------|--------------|--------|--------------|-------|--------------|-------|
|       | kW           | A      | kW           | A     | kW           | A     |
| 618L  | 9.3/12.4     | 45/52  | 9.3/12.4     | 31/36 | 7.8/9.3      | 12/13 |
| 624   | 13.9/18.6    | 67/77  | 13.9/18.6    | 39/45 | 11.6/13.9    | 18/19 |
| 634   | 18.2/24.3    | 88/101 | 18.2/24.3    | 51/59 | 15.2/18.1    | 23/25 |

**Screen Size And Weight**

| MODEL | SCREEN SIZE            | APPROX. SHIPPING WEIGHT (Box of 12) |
|-------|------------------------|-------------------------------------|
| 618L  | 17" x 25" (43 x 63 cm) | 45 lbs (21 kg)                      |
| 624   | 23" x 23" (58 x 58 cm) | 55 lbs (25 kg)                      |
| 634   | 23" x 33" (43 x 63 cm) | 75 lbs (34 kg)                      |