



# HCO100E

## Hybrid Convection Oven – Electric

### STANDARD FEATURES

- 4-pan capacity end load interior with 4" spacing
  - Utilizes standard 18 x 26" pans
- Patented self-contained spherical cast steam system
- Programmable digital control
  - Four stage baking
  - Auto off control
  - Auto vent
  - 99 programmable menus
- Energy saving idle mode
- Patent pending airflow system provides consistent, quality results effortlessly.
  - Never turn a pan mid-bake again.
- Wide hearth-style viewing window
- Stainless steel construction
- Removable slides for easy cleaning
- Shipped assembled

### OPTIONS & ACCESSORIES

- 3-pan capacity end load interior with 5.3" spacing
- Oven stacking kit
- Slide bridge kit – allows oven to accommodate pans smaller than 18" x 26"
- STAND-HCOSGL: 34"H stand base for use with one oven
- STAND-HCODBL: 20"H stand base for use with 2 stacked ovens



2 ovens on stand base shown



Area Reserved For Consultant & Contractor Approvals



19220 State Route 162 East  
Orting, WA 98360  
[www.baxterbakery.com](http://www.baxterbakery.com)

**Factory**  
(360) 893-5554

**Customer Care**  
(800) 777-2828  
or  
(800) 462-2778

**Customer Care Fax**  
(937) 332-2852



# HCO100E

## Hybrid Convection Oven – Electric

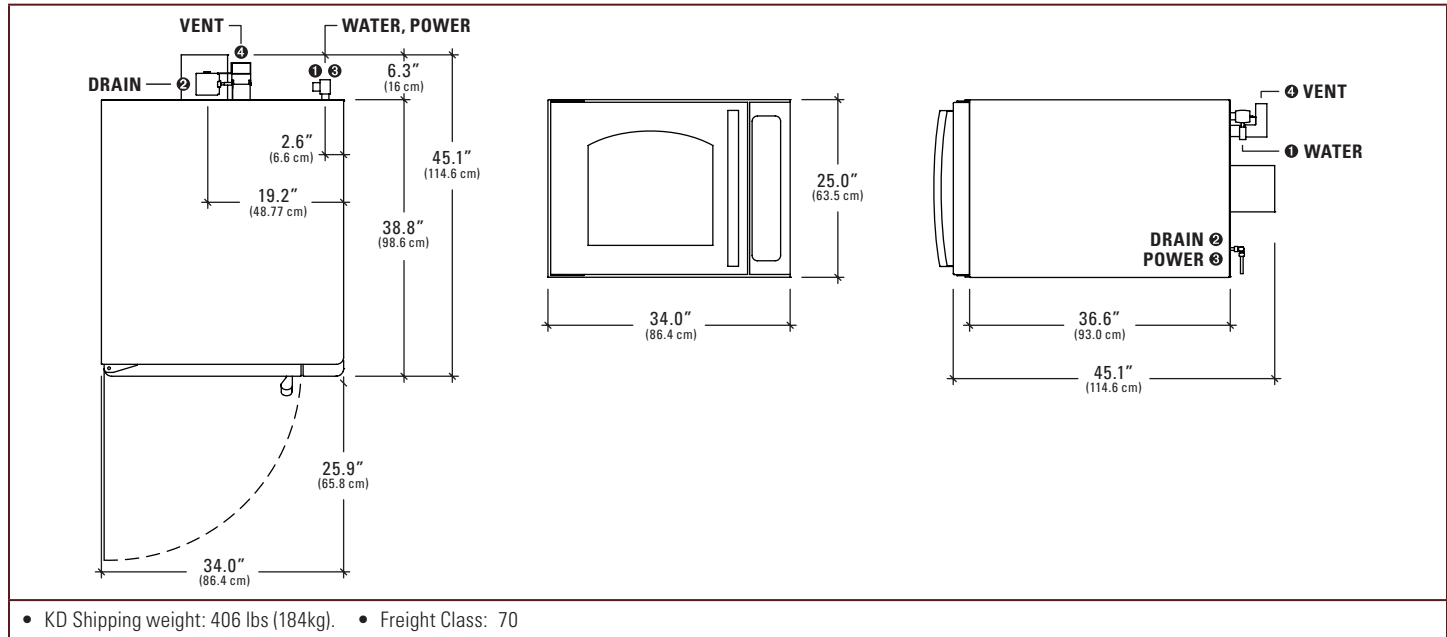

### UTILITIES & NOTES

- 1 Water:**  $\frac{3}{8}$ " NPT connection. Cold water @ 20-85 psi @ 0.5 GPM max flow rate.  
**Note:** Water supply must have the proper hardness, pH & chloride concentration. Consult your local water company and/or water conditioner dealer before installation.
  - **Recommended water hardness range:** 2-4 grains per gallon.
  - **Recommended pH range:** 7.0 to 8.0.
  - **Acceptable range for chloride concentration:** 0-30 ppm.
- 2 Drain:**  $\frac{3}{8}$ " tubing. Route to air-gap drain.
- 3 Power:** 208-240V/60/3 24.7-27.0 amps 7.8-10.3kW  
**Note:** Includes 6' cord, plug is not supplied.
- 4 Steam Vent:** Oven(s) may need to be installed under a Type I or Type II exhaust hood. An oven stacking kit allows the steam vents for two ovens to be tied together. Consult local code.

### INSTALLATION

The hybrid convection oven is shipped assembled, but requires qualified personnel to install and make utility connections. Caution – To reduce the risk of fire, the appliance is to be mounted on optional stand base or non-combustible surface.

#### Minimum clearances to combustible construction:

- 0 inches from sides
- 1" from rear
- Oven must be installed on a non-combustible surface.
- Access to right side needed (24"min) for service access.

### SHORT SPECIFICATION

The oven shall be of stainless steel construction, manufactured in the United States by Baxter Mfg. The footprint shall be no larger than 34.0"W x 45.1"D x 25.0"H and shall have an optional stand base provided to ensure proper installation upon a non-combustible surface. The oven shall be manufactured to allow a second oven stacked above. A stacking kit shall be used to ensure the ovens are stable when stacked two high on a stand base.

The oven's heating system shall be designed for power input of 208-240V 3Ph and shall utilize a bank of 3 tubular Incoloy<sup>®</sup>-sheathed elements. Elements shall be sized to maximize life, with a maximum watt density of 48W/in<sup>2</sup> and shall be individually removable for ease of service. The oven shall also include a patented self-contained spherical cast steam system which shall convert 16 oz. of water into steam within 15 seconds at a temperature of 400°F or better. The oven door shall utilize two panes of glass in the large viewing window. The interior glass panel shall open to allow cleanable access to both sides of both window panes.

The oven will bear the following agency approvals: UL for safety and sanitation for the U.S. & Canada, Manufacturer reserves the right to make changes in sizes and specifications.

Manufacturer reserves the right to make changes in sizes and specifications.



19220 State Route 162 East  
Orting, WA 98360  
www.baxterbakery.com

**Factory**  
(360) 893-5554

**Customer Care**  
(800) 777-2828  
or  
(800) 462-2778

**Customer Care Fax**  
(937) 332-2852