

Conveyors Tray Trac™ Conveyor Systems model TTM

Description:

The AVTEC Tray Trac™ is a unique tray assembly system, designed for tray preparation for hospitals, nursing homes, prisons and anywhere an assembly line to prepare trays is required. The system utilizes a series of tray carriers mounted to a drive chain, rotating around a series of sprockets. The system utilizes the “work facing approach to tray assembly and thus eliminates the extraneous motion of twisting and turning associated with straight-line tray systems. The system utilizes consistent spacing, easy recognition of tasks, limited range of motion, and consistent delivery to increase tray production. The Model TTM, modular-base unit, utilizes AVTEC manufactured hot and or cold portable units to standardize the tray line, allow flexibility, and eliminate the need for many ancillary pieces.

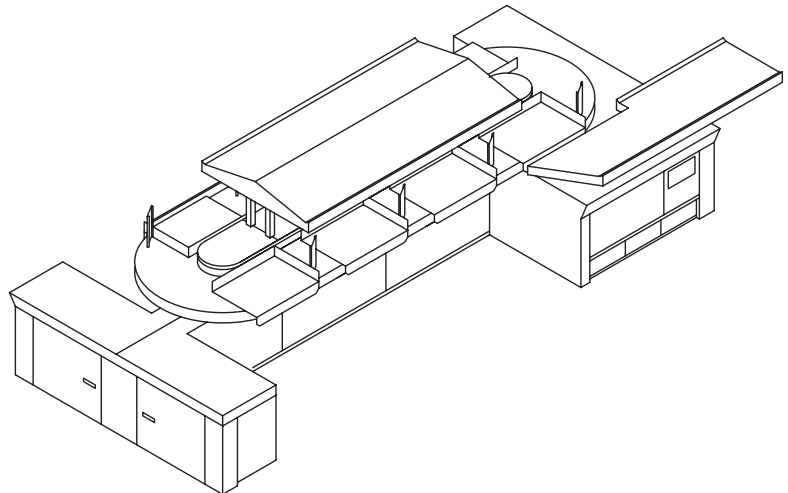

Specifications:

Provide AVTEC UL listed, NSF approved, Tray Trac Assembly System, Model TTM, with table base, _____ long x _____ wide, with food holding surface 30 ½” to 34 ½” above finished floor. Conveyor track length to be _____ long. Modular System shall contain non-refrigerated surfaces, mobile refrigerated units, mobile hot food well units, and other items as specified and shown on drawings.

System shall consist of a series of rotating removable tray carriers with UHMW polyethylene wear strips riding on a stainless steel track, cantilevered above the finished floor and 12” above the food holding surfaces. Removable tray carriers shall attach to a closed-path steel sprocket and chain located in a stainless steel housing. Top of drive housing shall be removable for access to all drive chain components.

Unit shall be constructed of stainless steel channel framing with exterior of 300 series, #4 finish stainless steel. Table top shall be 14 gauge, with all side panels access doors and mullions 16 gauge stainless steel. Access doors to be hinged and provided with recessed handles. Unit to be provided with adjustable leg assemblies with 4” adjustment. Unit to be complete with neoprene bumper guards on all sides and stainless steel splash guards over work surfaces.

Power for drive to be provided by a (¾) (1) HP 120VDC motor with silicone controlled rectifier, solid state controls and automatic bearing lubrication. Speed control and hour meter to be located inside access doors. Start /stop controls to be located at starter (and/or) checker station of tray line. Unit to include main disconnect for drive mechanism and individual modular energy distribution systems.

Unit to be provided with UL listed, AVTEC Modular Energy Distribution System running on each side of base and as part of the individual mobile sections, with main electrical disconnects. Modular system to house connection link plates consisting of point-of-use circuit breaker, and matching electrical outlet or connection. Link plates on 12” centers and shall provide power for all ancillary equipment as shown on drawing. Connection plates shall be interchangeable, with blank plates available for future connections.

KEC to determine size of crates that can be received at site and moved through building. If unit is to be shipped in sections, standard spline joints will be supplied at field joints. Field welding, if required, is the responsibility of the KEC. Mandatory supervision of assembly and start-up by factory authorized technician is required. Two weeks written notice of installation time required.

_____ Amps, 120/208/3F, _____ KW, 4-wire

_____ Amps, 120/208/3F, _____ KW, 4-wire

½” Hot and ½” cold water (Electrical) (Plumbing) services to terminate in (ceiling) (floor) by trades. Final connection by trades.

Standard Features:

- Chain link drive with removable tray carriers – no conveyor belt service problems
- Cantilevered tray carrier design saves floor space
- Tray carriers easily removable for cleaning
- Operator is facing tray line during operation – no turning or extraneous motions
- Tray interval remains constant
- Checker unload station allows continuous operation-no stoppage on the line for checking
- Uniform work surface containing hot and cold units
- Menu cards easily readable at 45% angle towards operator
- AVTEC Modular EDS allows for powering ancillary equipment w/one electrical service for entire system
- Allows for easy relocation or adding of electrical connection

Optional Accessories:

- Integral Starter Station: Side mounted 2 tier, 6 bin with: 3 extra bins in table top and top shelf
- End mounted over trac, 2-tier, 10 bin w/top shelf
- Mounted under trac, 5-bin
- ____" x ____" cutout for tray dispenser (to be verified)
- Tray Unload Station, 5 ft. (5 ft. std.)
- ____ (Qty) Portable 6-well (Cold)(Hot) Food Units
- ____ (Qty) Portable 5 well (Cold)(Hot) Food Units
- ____ (Qty) Portable 4 well (Cold)(Hot) Food Units
- ____ (Qty) Portable Cold Top Units- 3 Bun Pan size
- ____ (Qty) Foot Operated Momentary Stop Switch(es)
- ____ (Qty) Angle Double Side Over shelf, 38" d x ____ ft. lg.
- S/S Fluorescent Work Light Fixtures (over table base)
- S/S Fluorescent Work Light Fixtures (over tray carrier)
- Checker Audio Call System w/ microphone & 2 speakers
- Timer/Programmer, 7-Day, single channel
- Door Locks (2)
- Heavy duty casters, in lieu of legs

Top View

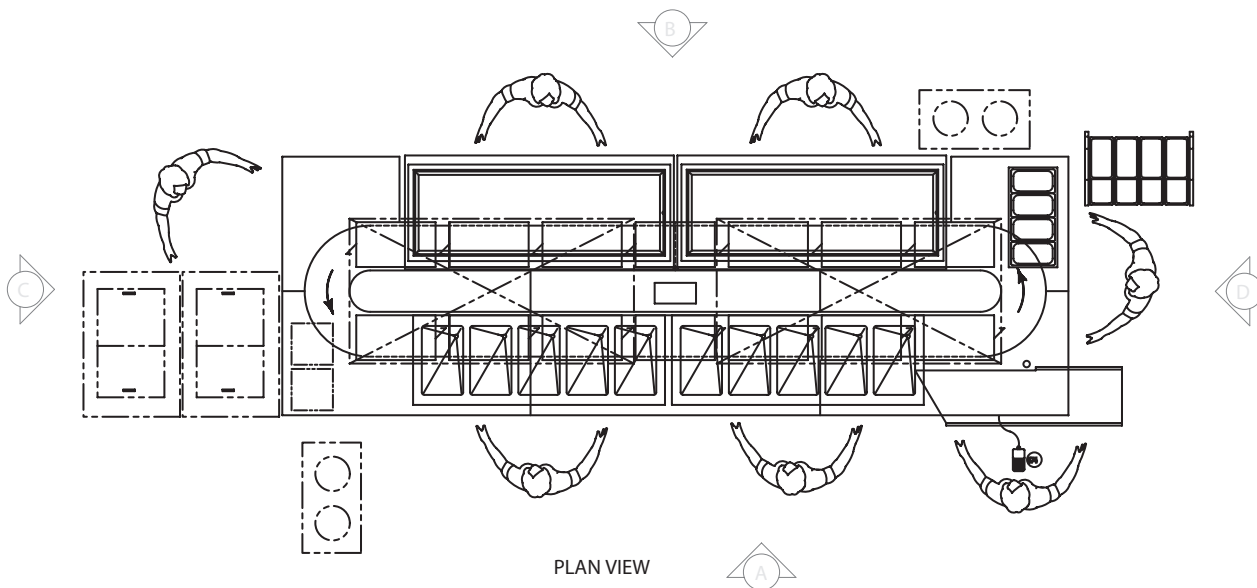

Front & Side Views

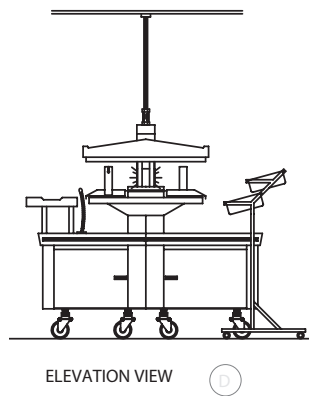
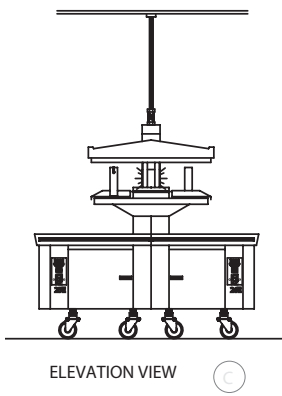
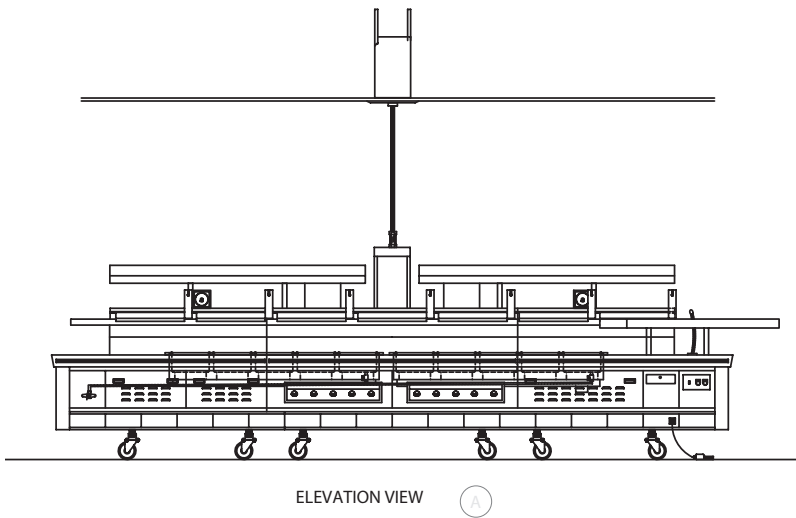
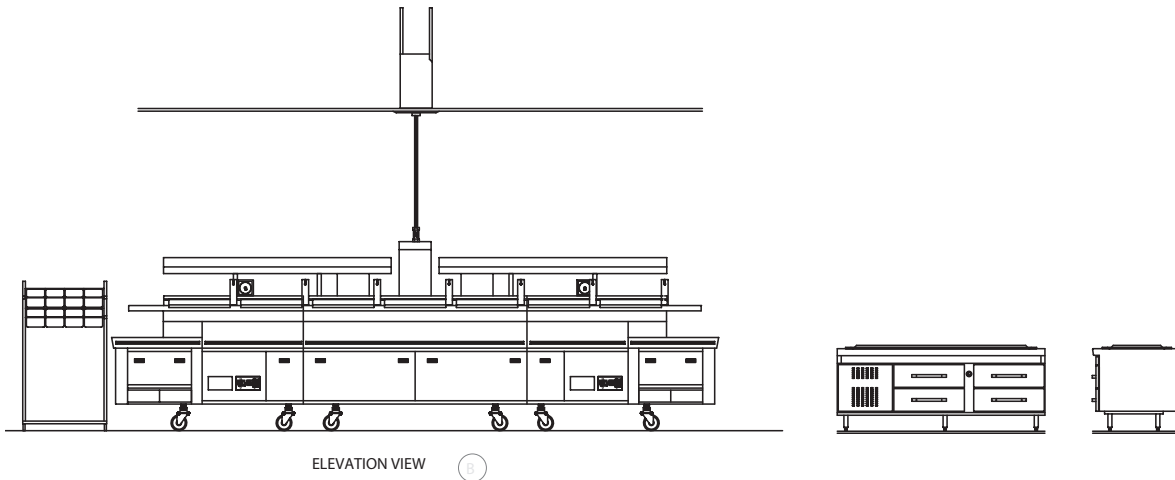

Tray Trac Application Data

*Maximum No. of Hot Food Wells

OA Length	Trac Length	Overshelf Length	Single	Double
12'	11' 2"	9'	6	8
15'	13' 5"	11' 3"	8	10
17'	15' 8"	13' 6"	9	12
19'	17' 11"	15' 9"	10	14
21'	20' 2"	18'	13	16
24'	22' 5"	20' 3"	15	18
26'	24' 8"	22' 6"	17	22
28'	26' 11"	24' 9"	19	24
30'	29' 2"	27'	21	26
33'	31' 5"	29' 3"	23	28

*If used with integral unload station. Add 3" in width if "double" hot food wells are used.

