

OPERATORS MANUAL

This manual provides
Installation & Operating instructions for



NOTIFY CARRIER OF DAMAGE AT ONCE.

It is the responsibility of the consignee to inspect the container upon receipt of same and to determine the possibility of any damage, including concealed damage. Avtec suggests that if you are suspicious of damage to make a notation on the delivery receipt. It will be the responsibility of the consignee to file a claim with the carrier. We recommend that you do so at once.

Information contained in this document is known to be current and accurate at the time of printing/creation. Unified Brands recommends referencing our product line websites, unifiedbrands.net, for the most updated product information and specifications.

AVTEC.



1055 Mendell Davis Drive
Jackson, MS 39272
888-994-7636, fax 888-864-7636
avtecind.com

Table of Contents

Types of Systemspage 4
Installation Requirements for Avtec Ventilation Hoods.....page 5
Canopy Hoodspage 5
Exhaust Fans & Ductspage 6
Control Panelspage 7
Fresh Air Supply Fanspage 7
Side Skirtspage 8
Top Enclosure Panelspage 9
Stainless Steel Wall Panelspage 10
Operation Instructions Start-Check-Balancepage 11
Direct Draw Hoodspage 11
Make-Up Air Hoodspage 11
Final Air Balance Make-Up Air Hoodback cover

SAFETY PROCEDURES

- Do not attempt to service this unit yourself as removing covers may cause unnecessary exposure to dangerous voltage.
- Never connect the unit to a power source while standing in water. Wet hands and wet floors should be avoided when connecting any electrical appliance to a power outlet.
- Fans may have multiple power connections. Make sure all fans are isolated from power prior to performing maintenance.

Installation Instructions

TYPES OF SYSTEMS

This manual covers three of the basic types of systems offered by Avtec:

- TAKU-Baffle Filter (AF)
- Modular Grease Extractor (AX)
- Auto Wash Down (AW)

BAFFLE FILTER (AF) SERIES

Model AF ventilators are listed by UL and are built in accordance of NFPA-96 for use with UL listed fire extinguishing systems for duct hood protection. They are available with or without an automatic fire damper. They utilize UL classified removable baffle filters to extract grease and provide a limited fire barrier. The canopy contains a hidden grease trough and removable cup. Surface, plenum and duct collar fire extinguishing systems may be factory supplied.

MODULAR GREASE EXTRACTORS (AX) SERIES

Model AX ventilators are listed by UL and are built in accordance of NFPA-96 for use with UL listed fire extinguishing systems for duct hood protection. They are available with or without an automatic fire damper. These models utilize high velocity removable grease extractors. The canopy contains a hidden grease trough and removable cup. Surface, plenum and duct collar fire extinguishing systems may be factory supplied.

AUTO WASH DOWN (AW) SERIES

Model AW ventilators are listed by UL and are built in accordance of NFPA-96 for use with UL listed fire extinguishing systems for duct hood protection. They are available with or without an automatic fire damper. These systems utilize a high velocity grease extractor and an integral water wash system cleans the inside of the grease extraction chamber either by manual activation of the Wash Start button or by a programmable timer. The duration of the wash is electronically controlled. The wash system is also activated by an electrical thermostat or a manual switch in the event of a fire condition. A surface fire extinguishing system is required and may be factory supplied.

Installation Instructions

INSTALLATION REQUIREMENTS FOR ALL AVTEC TAKU VENTILATION HOODS

Avtec hoods are provided with adjustable hanging brackets designed to receive 1/2" threaded rod with a 1/2" nut and washer. Supporting rods must be connected to all factory installed brackets. Recommended hanging height is 6'-6" above finished floor for canopies. Low side wall ventilators should be installed directly upon a Avtec base or on a rered wall. If wall mounted, the bottom of the vent should be 36" above finished floor.

ALL AVTEC VENTILATION SYSTEMS MUST BE INSTALLED IN ACCORDANCE WITH NFPA-96, REMOVAL OF SMOKE AND GREASE-LADEN VAPORS FROM COMMERCIAL COOKING EQUIPMENT.

CANOPIES

1. Check all local codes prior to installation. Special requirements may be necessary depending upon building material construction.
2. Move crated hood to location of installation and very carefully uncrate hood.
3. Raise hood to proper hanging height.
4. Suspend hood from adequate roof supports using 1/2" threaded rods with nuts and washers (See Fig. 1).
5. Level hood left to right and front to back.
6. Brackets are provided for hoods which are to be installed end to end or back to back. Bolt brackets together using 3/8" bolt through holes provided (See Fig. 2).
7. Install C channel where the ends of the hood meet and install T moldings on front face of hoods where they join. High temperature silicone can be used to install channel and T moldings (See Fig. 3).
8. For make-up air hoods, the supply collar with built-in UL listed fire damper and air volume damper must be installed per instructions on collar.
9. Provide a removable service door in supply duct near fire damper (See Fig. 4).

Figure 1

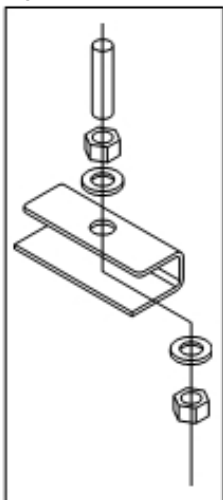

Figure 2

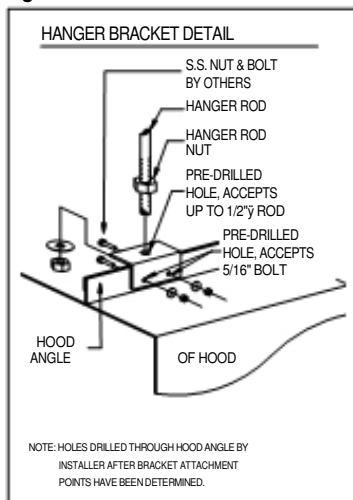

Figure 3

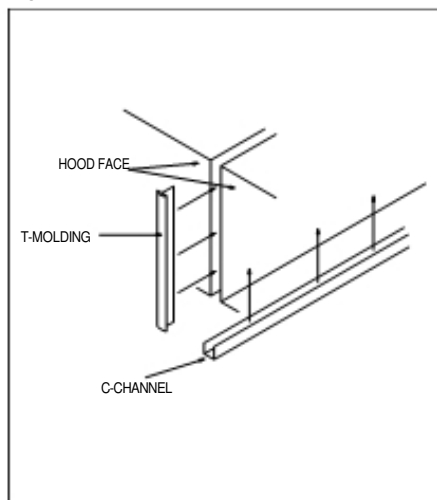
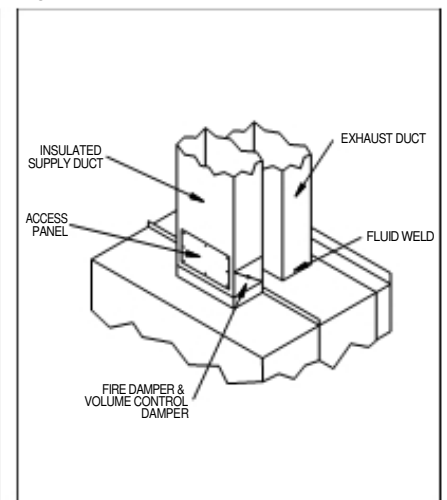

Figure 4



Installation Instructions

EXHAUST FAN & DUCT

1. Check all local codes prior to installation.
2. All exhaust fans are supplied with a hinge kit and grease box.
3. The exhaust fan curb should be installed directly above the hood if possible. Always maintain the shortest duct run possible.
4. Cut hole and seal exhaust fan curb to roof.
5. Duct shall be sized to provide air velocities not exceeding 1200 FPM.
6. Install hinges and airline cable on exhaust fan cap and metal curb. Remember to leave ample room for fan to tilt back. Fan will remain in tilted back position.
7. Install grease collection box on side of fan that has grease tube discharge.
8. The exhaust duct must be constructed of 16 gauge carbon steel or 18 gauge stainless steel. All seams must be fluid welded.
9. A duct transition should be provided below exhaust fan inlet.
10. The exhaust duct must be fluid welded to hood collar.
11. Make all necessary electrical connections and check fan for proper rotation.

NOTE: Fan will exhaust air running in wrong direction.

Installation Instructions

Control Panel (if provided)

WALL ATTACHMENT

Control panels are provided with all auto wash type ventilators (Model AW) and are optional with all baffle filter type (AF) and modular grease extractor type (AX). Control panels with models (AF) and (AX) do not have the auto wash plumbing assembly compartments.

Control panel dimensions and connection detail are shown on the enclosed shop drawing. Panels may be surfaced mounted, partially recessed or fully recessed.

SURFACE MOUNTED

Drill four holes in ventilator plumbing compartment as required. Be careful not to damage any components. Avoid drilling into electrical compartments. Bolt to wall with anchor bolts or other acceptable means. Weight of control panel varies from 90 to 200 lbs.

RECESSED MOUNTED

Cut hole in wall 1/2" greater than overall dimensions of the control box (shown on shop drawing). Spacers or support angles may be necessary to provide proper support. It is recommended that the panel be bolted to wall similar to method used for surface mounted above.

PAWS CONTROL PANEL

The Programmable Automatic Wash Sequence (PAWS) panel is designed to control the operation of the ventilator exhaust and make-up air fans and wash the grease extraction plenum with hot water/detergent solution. The fan operation and wash sequence can be started and stopped manually or programmed for automatic operation.

FRESH AIR SUPPLY FAN (See Fig. 5 on page 8)

1. Check all local codes prior to installation.
2. Supply fan inlet must be located to minimum 10'-0" from the exhaust fan. If 10' is not possible a 3' vertical separation **may*** be acceptable.
3. Cut and seal supply fan curb to roof.
4. Duct shall be constructed of 22 or 24 gauge steel. Insulated duct material should be used to eliminate frost and/or condensation.
5. Duct shall be sized to provide air velocities not exceeding 1200 FPM.
6. A volume control damper, provided in the duct just above the supply collar that contains the UL listed re damper, should be properly set to supply CFM required.
7. If the hood is provided without the supply collar installed, it must be installed per the instructions provided on the collar.
8. Carefully place the supply fan on roof curb. Face supply fan inlet away from prevailing winter wind. Electrical back draft damper is recommended in cold climates.
9. Bolt or screw fan to fan curb.
10. Make all necessary electrical connections and check fan for proper rotation.

NOTE: Fan will supply air running in wrong direction.

***Dependent on local code requirements.**

Installation Instructions

Side Skirts

Figure 5

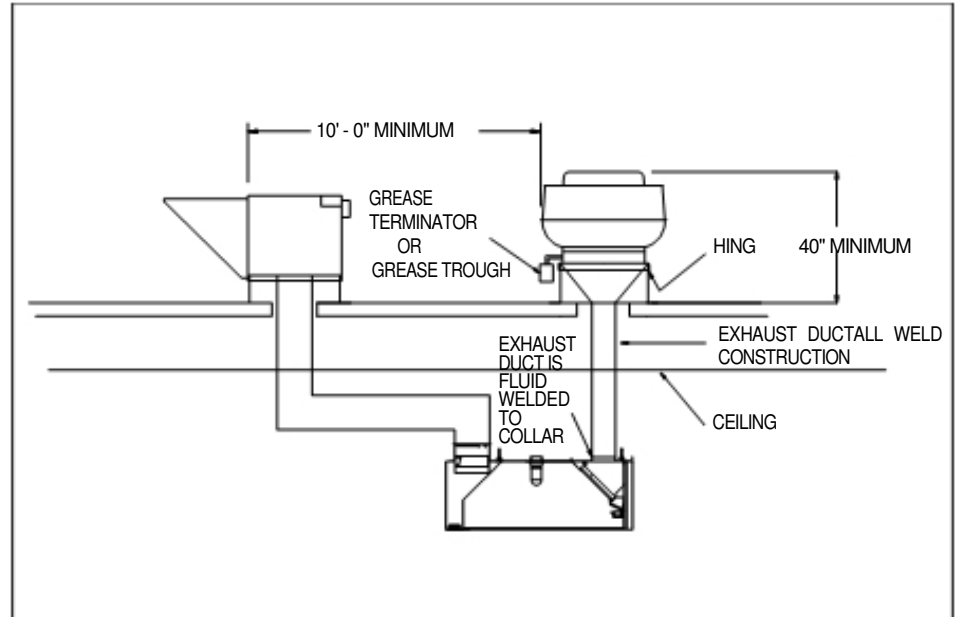

FRESH AIR SUPPLY FAN CONTINUED (See Fig. 6)

PIECES PROVIDED

One or two optional side skirts may be provided.

1. Side skirts are offset at the top and have a 90° bend inward at the rear.
2. Skirts are to overlap the outside of the hood. Bolts and acorn nuts should be attached per the drawing (stainless bolts and acorn nuts supplied).
3. Skirt flange should be screwed to the wall (screws not provided).

Figure 6

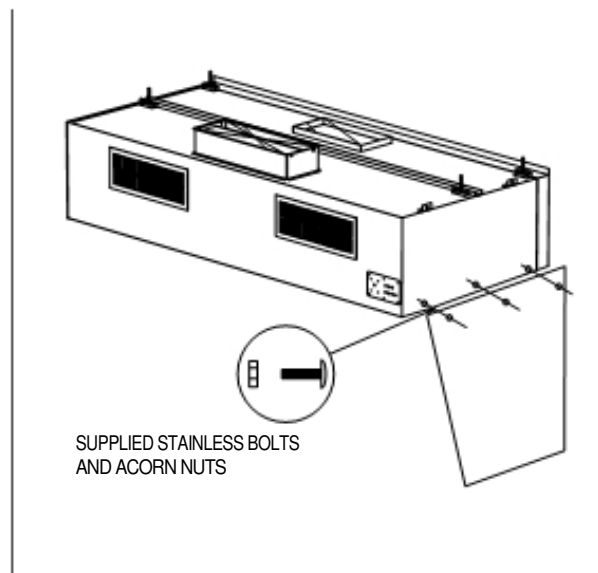

Installation Instructions

Side Skirts

TOP ENCLOSURES INSTALLATION OF ENCLOSURE PANELS (See Fig. 7-9)

PIECES PROVIDED

Enclosure panels are provided for exposed side(s) of hood(s).

1. Hoods ordered with enclosure panels will be shipped with threaded metal studs installed on perimeter of hood top where panels are to be installed. Retaining nuts and washers are installed on the studs prior to shipping.
2. Loosen nuts on studs. Slide enclosure panel under loosened nuts. Holes in panels are open on end so nuts do not have to be removed.
3. If enclosure panels are installed on one or more hoods butted end to end, the butting ends of the front enclosure panels should be bolted together.

Figure 7

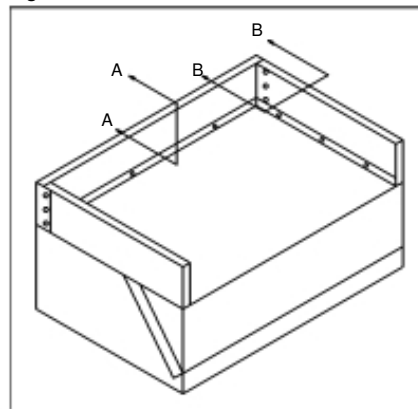

Figure 8

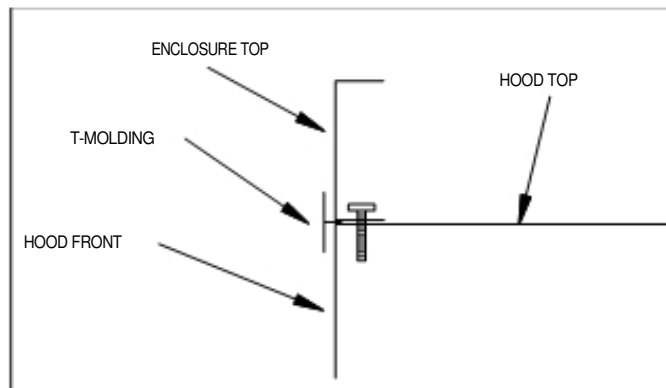
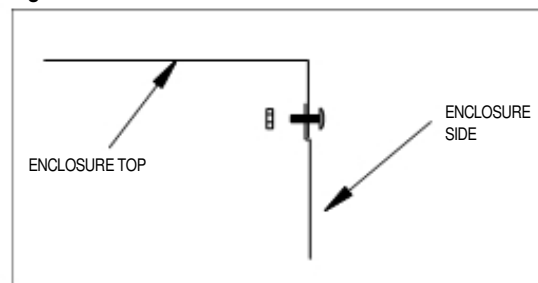

Figure 9



Installation Instructions

Insulated Stainless Steel Wall Panels

PIECES PROVIDED

Insulated wall panel comes in two pieces.

- A. Top panel will have a 1" flange full length top and bottom with interlocking slots located on the bottom.
- B. Bottom panel will have interlocking tabs on top and full length 1" flange on bottom.

INSULATED WALL PANEL (See Fig. 10)

1. Install wall panels prior to hanging hood(s).
2. Install top panel first. Top of panel should be installed 6'-6" A.F.F. and level. Screw panel to wall making sure slotted holes are facing floor.
3. Install lower panel by sliding tabs into slotted holes in upper panel, screw bottom flange to wall.
4. Caulk horizontal seam with NSF approved silicone sealant.
5. When hood is hung it will rest on top panel.

NOTE: Be careful to not damage wall panel face when installing hood.

SINGLE THICKNESS WALL PANEL (See Fig. 11)

1. Install wall panels prior to hanging hood(s).
2. Install seam strips at proper locations and screw to wall.
3. Apply glue to wall between seam strips.
4. Slip one end of wall panel into seam strip, pull out middle of panel and slip other end of panel into other seam strip. Gently apply pressure over entire wall panel to secure to wall. Wall bands for side walls are provide with 1" return bend, which is to be located behind rear wall panels.

Figure 10

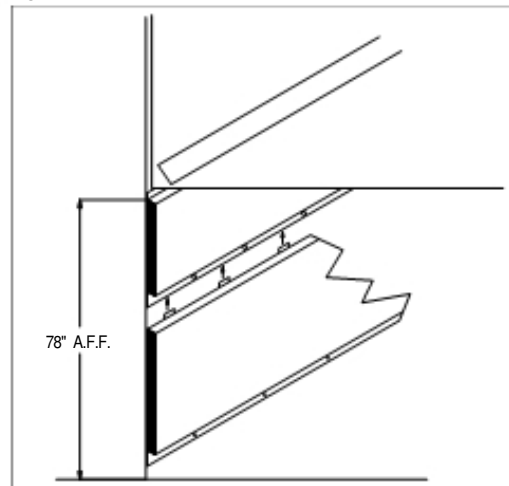
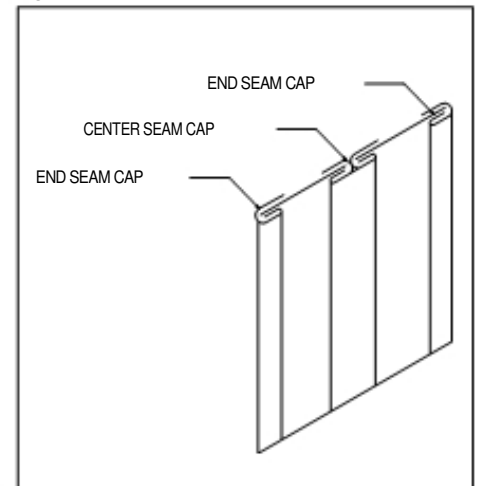

Figure 11



Start / Check / Balance

DIRECT DRAW HOODS

1. Close all doors and windows.
2. Operate all exhaust fans, even fans serving other hoods, make-up air units and building HVAC.
3. Turn on all cooking equipment under the hood to preheat to operating temperature.
4. Produce large quantities of smoke.
5. Observe capture of vapors.
6. If all vapors are not captured, increase exhaust fan RPM.
7. Check air pressure in kitchen. Pressure must be negative relative to dining room pressure.
8. Air velocities entering the kitchen from the dining room should not exceed 100 FPM. No air should be moving toward the dining area.
9. Repeat steps 6 and 7 until all vapors are captured.
10. Same as step 7 with bottom of next page.

NOTE: The exhaust and supply (if any) air flow rates were established under controlled laboratory conditions, and greater exhaust and/or lesser supply air may be required for complete vapor and smoke removal in specific installations.

MAKE-UP AIR HOODS Exhaust Fan(s)

1. Open all doors and/or windows leading to outside.
2. Start the exhaust fan only. Do not run the supply fan or make-up unit.
3. Refer to drawings and/or UL information label on hood for proper CFM requirements.
4. Adjust speed of exhaust fan to obtain proper air velocities and CFM through grease filters.

SUPPLY FAN OR MAKE-UP AIR UNIT

1. Start the supply fan and/or make-up unit only. Do not run the exhaust fan.
2. Refer to drawings or UL information label on hood for proper CFM requirements.

Final Air Balance

MAKE-UP AIR HOODS

1. Close all doors and windows.
2. Operate all exhaust fans even those serving other hoods, supply fans, make-up air unit and building HVAC system.
3. Turn on all cooking equipment under the hood and preheat to operating temperature.
4. Produce large quantities of smoke or steam.
5. Observe capture of vapors.
6. If all vapors are not totally captured, tune the system by adjusting the air volume control damper installed in the supply collar. Slightly reduce the amount of supply air directed under the hood until full capture is obtained.

UNIFIED BRANDS