

OPERATORS MANUAL

This manual provides
Installation & Operating instructions for

MOTORIZED CONVEYOR SYSTEM

For Models:
CB, CI



NOTIFY CARRIER OF DAMAGE AT ONCE.

It is the responsibility of the consignee to inspect the container upon receipt of same and to determine the possibility of any damage, including concealed damage. Avtec suggests that if you are suspicious of damage to make a notation on the delivery receipt. It will be the responsibility of the consignee to file a claim with the carrier. We recommend that you do so at once.

Manufacture Service/Questions 888-994-7636.

Information contained in this document is known to be current and accurate at the time of printing/creation. Unified Brands recommends referencing our product line websites, unifiedbrands.net, for the most updated product information and specifications.



1055 Mendell Davis Drive
Jackson, MS 39272
888-994-7636, fax 888-864-7636
avtecind.com

TABLE OF CONTENTS

I.	PRODUCT DESCRIPTION	1
II.	TYPICAL APPLICATIONS	1
	A. <u>Tray Assembly</u>	1
	B. <u>Plate Assembly</u>	1
	C. <u>Tray Return</u>	1
	D. <u>Dish and Rack Bussing</u>	1
III.	INSTALLATION REQUIREMENTS	1
	A. <u>Mechanical</u>	1
	1. <u>Slider Bed</u>	1
	2. <u>Vertical Height Adjustment</u>	1
	3. <u>Mono-Rail Return</u>	1
	4. <u>Roller Return</u>	1
	5. <u>Belt Assembly - Hinge Type</u>	2
	6. <u>Belt Assembly - Chain Type</u>	2
IV.	ELECTRICAL OPERATION	2
	A. <u>Over Counter Control Panel</u>	2
	1. <u>External Controls</u>	3
	a. <u>Disconnect Switch</u>	3
	b. <u>Speed Control</u>	3
	c. <u>Conveyor Stop Switch</u>	3
	d. <u>Conveyor Start Switch</u>	3
	e. <u>Conveyor Wash Switch</u>	3
	i. <u>Belt Wash Only</u>	3
	ii. <u>Belt Wash and Automatic Flush</u>	3
	2. <u>Visual Indicators</u>	3
	a. <u>Conveyor ON Indicator</u>	3
	b. <u>Belt Wash ON Indicator</u>	4
	c. <u>Detergent Low Indicator</u> (optional)	4
	d. <u>Conveyor Flush ON Indicator</u> (optional)	4
	3. <u>Internal Controls</u>	4
	a. <u>Wash Duration</u>	4
	b. <u>Flush Duration</u>	4
	B. <u>End Conveyor Control Panel</u>	4
	1. <u>Speed Control</u>	5
	2. <u>Conveyor Wash Switch</u>	5
	3. <u>Conveyor Stop Switch</u>	5
	4. <u>Conveyor Start Switch</u>	5
	C. <u>Remote Controls</u>	5
	1. <u>Speed Control</u>	5
	2. <u>Conveyor Stop Switch</u>	5
	3. <u>Conveyor Start Switch</u>	5
	4. <u>Momentary Switch</u>	5

IV. ELECTRICAL OPERATION (continued)	5
D. <u>End Switches</u>	5
1. <u>Limit Switch</u>	5
a. <u>Photocell Beam Type</u>	5
b. <u>Arm Switch Type</u>	5
c. <u>Pressure Type</u>	5
2. <u>Anti-Jam Switch</u>	6
E. <u>Motor Control Adjustments</u>	6
V. MAINTENANCE	6
A. <u>Cleaning</u>	6
1. <u>Drip Pan - for Hinge Type Belt</u>	6
2. <u>Drip Pan - for Chain Type Belt</u>	6
3. <u>External Scrap Basket (Tank)</u>	6
4. <u>External Scrap Basket (Tail)</u>	7
5. <u>Wear Strip</u>	7
B. <u>Detergent Wash and Flush</u>	7
C. <u>Access for Servicing</u>	7
1. <u>Hinged Side Panel</u>	7
2. <u>Removable Side Panel</u>	7
3. <u>Access Plate</u>	7
4. <u>Remote Detergent Housing</u> (optional)	8
5. <u>Drive Housing</u>	8
6. <u>Beam Switch</u>	8
D. <u>Routine Servicing</u>	8
1. <u>Gear Box</u>	8
2. <u>Bearings</u>	8
3. <u>Belt</u>	9
4. <u>Intermediate Drive Chain</u>	9
VI. PARTS LIST	10-12

I. PRODUCT DESCRIPTION

Your AVTEC Conveyor is a custom engineered member of the AVTEC Conveyor Product Group. This manual is intended to describe the product, its applications, installation, operation and maintenance. Since each of our products is engineered and manufactured specifically for you, this manual is written in general terms and may describe options that do not apply to your conveyor. Specific "As Built" shop drawings are included with your conveyor for reference. Except for specials, these units are listed with Underwriters Laboratories Inc. [UL] and the National Sanitation Foundation [NSF].

CAUTION: This equipment is electrically driven by a motor that is of sufficient power to cause personal injury if improperly or recklessly used. There are a number of safety features engineered into the design and construction of this product, but common sense precautions [i.e., avoid wearing loose clothing, jewelry, etc.] and alertness should be practiced at all times.

These conveyors are intended primarily to move trays or racks of dishware and/or utensils. Transportation of individual items such as flatware and food is not recommended.

II. TYPICAL APPLICATIONS

A. Tray Assembly

Empty trays are loaded on one end of the conveyor belt and, as they progress along the length of the conveyor, selected food items and condiments are placed on the trays. Trays are then off-loaded from the conveyor and transported to the serving location.

B. Plate Assembly

Individual plates are placed on the conveyor belt and selected food items are placed on the plates. These plates are then off-loaded at the end of the conveyor and transported to the serving area.

C. Tray Return

Soiled dishes and trays are placed on the conveyor belt and transported from the dining area to the dishwashing area, where they are scrapped and otherwise prepared for the dishwashing machine.

D. Dish and Rack Bussing

These conveyors can be single or double belt width design and transport plates, utensils and racks of soiled hollowware, from the scrapping areas to the dishwashing machine. Dishware can be stacked and transported without racks.

III. INSTALLATION REQUIREMENTS

A. Mechanical

1. Slider Bed

When the conveyor is to be used in a generally dry environment, field joints are usually bolted. To assemble, slide the sections of the conveyor together and align the edges, then clamp sections and bolt together using hardware provided. Remove clamps. [See Fig. 3.1]

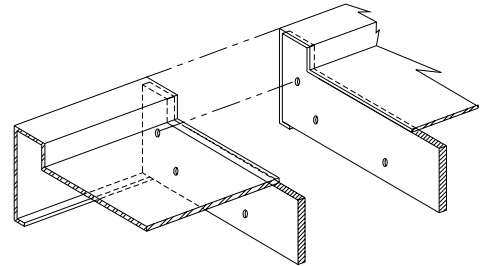

Fig. 3.1

2. Vertical Height Adjustment

Permanently located conveyors should be leveled to within 1/16" from side to side and 1/32" per foot from end to end. [Example: An 8'-0" long conveyor section the maximum deviation between the highest and lowest points should not exceed 1/4".] This adjustment can be made by adjusting the feet up and down as required.

NOTE: When using mobile conveyors, care should be taken to operate the conveyor on a relatively level section of floor.

3. Mono-Rail Return

On conveyors equipped with a mono-rail return system, it is important to align the lower guide at all field joints during installation to insure proper belt operation. [See Fig. 3.2]

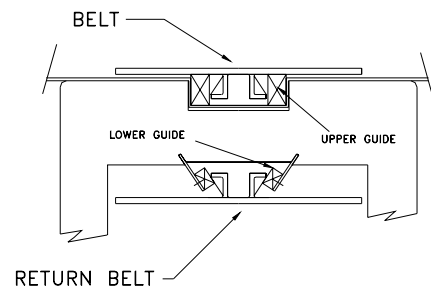

Fig. 3.2

4. Roller Return

On conveyors equipped with a roller return, feed the belt over all rollers. Slight tension on the belt should allow the ends to come together and still leave slack under the slider bed. [See Fig. 3.3].

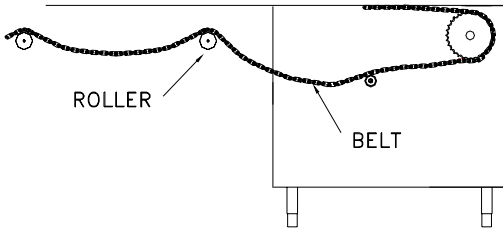
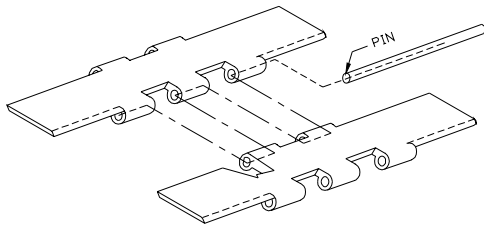

Fig. 3.3

5. Belt Assembly - Hinge Type

With hinge type belts, align the ends of the belt and insert pin. To disassemble, simply remove the pin. [See Fig. 3.4].



HINGE BELT ASSEMBLY

Fig. 3.4

6. Belt Assembly - Chain Type

For belts with integral drive chain and removable individual slats, the links and slat required for assembly are shipped loose. To assemble, draw the inner links together then inserting the outer links, snap in place. Attach the slat by snapping it in place, being careful to note the direction of travel. To disassemble, remove the slat by inserting a screwdriver between the outer link and the inboard edge of the slat and pry outward. Wedge the inner and outer links apart to disassemble the drive chain. [See Fig. 3.5].

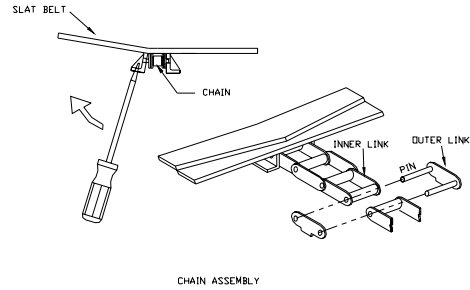

CHAIN ASSEMBLY

Fig. 3.5

IV. ELECTRICAL OPERATION

A control wiring diagram of your specific conveyor is included at the end of this manual. The following is a brief, verbal description of the electrical related features of your unit.

A. Over Counter Control Panel (See Fig. 4.1)

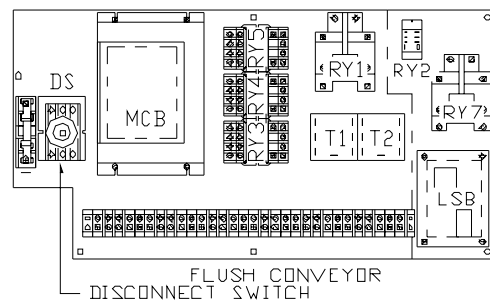
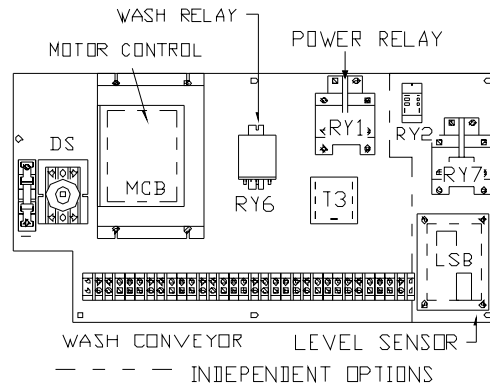
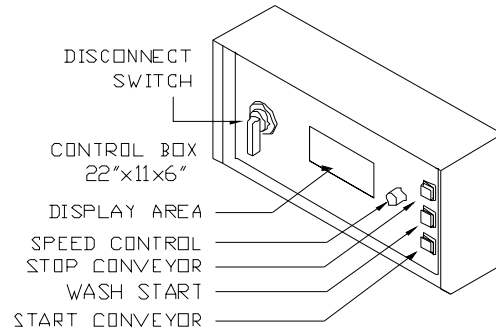

Fig. 4.1

1. External Controls

a. Disconnect Switch

The pistol-grip Disconnect Switch mounted on the left side of the Conveyor Control Panel is used only when servicing the AVTEC conveyor. To remove power from the conveyor and the Conveyor Control Panel, rotate the handle counter-clockwise so that it is in the three o'clock position.

The Disconnect Switch must be in the "Off" position in order to open or close the front plate of the Conveyor Control Panel. When it is in the "Off" position, a lock may be installed in the handle to prevent the switch from being turned back on. Turn the handle clockwise to the six o'clock position in order to restore power to the conveyor and the Conveyor Control Panel.

b. Speed Control

The speed control knob is located just to the right of the center of the panel. Turn the knob clockwise to increase the speed of the conveyor belt. Turn the knob counter-clockwise to reduce the speed of the conveyor belt.

c. Conveyor Stop Switch

The uppermost switch is a red "Stop" switch. Pressing the red "Stop" switch will cause all operations to stop immediately. If the conveyor is running, it will stop. If the conveyor is in a wash cycle, the conveyor will stop and the water solenoid valve and the detergent pump will shut off.

d. Conveyor Start Switch

The lowest of the three (3) switches mounted on the right hand side of the Conveyor Control Panel is a green "Start" switch. Pressing the green "Start" switch will cause the conveyor belt to begin running. The conveyor will continue to run until the red "Stop" switch is pressed or until power is otherwise removed from the Conveyor Control Panel.

e. Conveyor Wash Switch

The center switch mounted on the right-hand side of the Conveyor Control Panel is the blue "Wash" switch. There are two alternative wash formats.

i.) Belt Wash Only

If the blue "Wash" Switch is pressed while the conveyor is running, the water solenoid valve and the detergent pump will be activated. The water and detergent will continue to run for a preset period of time. At the conclusion of that time period, the water wash solenoid and the detergent pump will shut off and the conveyor will continue to run.

ii.) Belt Wash and Automatic Flush

If the blue "Wash" Switch is pressed while the conveyor is running, the flush solenoid will be energized and the detergent pump will be activated. The flush and detergent pump will continue to run for a set period of time. At the conclusion of that time period, the flush solenoid will turn off and the water wash solenoid will be energized. The detergent pump will remain on. When the wash timer runs out, the wash solenoid valve and detergent pump will shut off and the conveyor will continue to run.

2. Visual Indicators

There are four (4) indicators located in the center of the Conveyor Control Panel. These illuminate to indicate that various conditions and/or operations are occurring. Your specific conveyor may not be equipped with all of these features.

a. Conveyor ON Indicator



Fig. 4.2

A light will come on whenever the conveyor is on. The words "CONVEYOR ON" and "TRANSPORTADOR PRENDIDO" will also be illuminated. (See Fig. 4.2)

b. Belt Wash ON Indicator



Fig. 4.3

A light will come on whenever the conveyor belt wash is on. The words "BELT WASH ON" and "LAVADO DE BANDA" will also be illuminated. (See Fig. 4.3)

c. Detergent Low Indicator (optional)

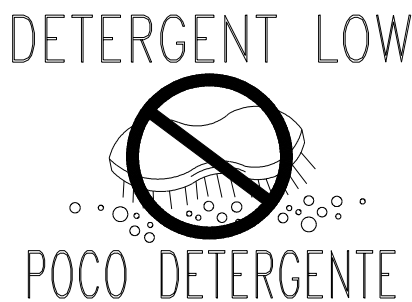

Fig. 4.4

A light will come on whenever the detergent level is low. The words "DETERGENT LOW" and "POCO DETERGENTE" will also be illuminated. The light will automatically be extinguished when the detergent tank is refilled. The detergent pump will be inoperative while the detergent level is low. (See Fig. 4.4)

d. Conveyor Flush ON Indicator (optional)

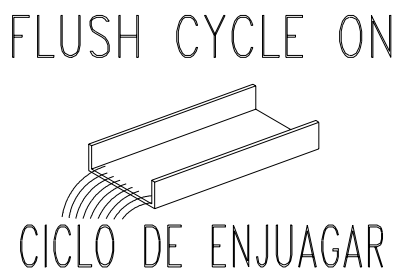

Fig. 4.5

A light will come on during the Conveyor Flush Cycle. The words "FLUSH

CYCLE ON" and "CICLO DE ENJUAGAR" will also be illuminated.

3. Internal Controls

a. Wash Duration

The duration of the wash is controlled by a potentiometer (marked "WASH") located inside the control panel. Turning the knob clockwise increases the duration of the wash cycle. The wash duration should be set after the conveyor has been in use and a comfortable operating speed has been determined. The wash should last long enough for the conveyor belt to make two (2) complete passes through the wash compartment. The wash duration should be readjusted if the belt speed is changed significantly.

b. Flush Duration

The duration of the flush is controlled by a potentiometer (marked "FLUSH") located inside the control panel. Turning the knob clockwise increases the duration of the flush cycle. The flush duration should be set after the conveyor has been in use and a comfortable operating speed has been determined. The flush should last long enough for the conveyor belt to make one (1) complete pass through the wash compartment; some applications may require two complete passes for satisfactory cleaning depending on amount of food soil and frequency of wash/flush use. The flush duration should be readjusted if the belt speed changes significantly.

B. End Conveyor Control Panel

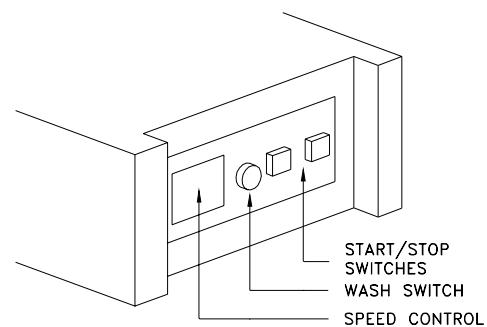

Fig. 4.6

1. Speed Control

There is a knob located on the exterior of the panel that controls the belt speed. Turn the knob clockwise to increase the speed of the conveyor belt. Turn the knob counter-clockwise to reduce the speed of the conveyor belt.

2. Conveyor Wash Switch

This switch is used to operate the wash cycle manually.

3. Conveyor Stop Switch

There are two (2) switches mounted on the outside of the Conveyor Control Panel. The red switch to the left is the "Stop" switch. Pressing the "Stop" switch will cause all operations to stop immediately. If the conveyor is running, it will stop. If the conveyor is in a wash cycle, the conveyor will stop and the water solenoid valve and the detergent pump will shut off.

4. Conveyor Start Switch

The green switch mounted to the right of the Conveyor Control Panel is the "Start switch. Pressing the green "Start" switch will cause the conveyor belt to begin running. The conveyor will continue to run until the red "Stop" switch is pressed or until power is otherwise removed from the Conveyor Control Panel. [Exception: Conveyors equipped with a momentary switch. If you press the momentary switch while the conveyor is already running, the conveyor will continue to run while the switch is depressed. The conveyor will turn off when the switch is released.]

C. Remote Controls (Optional)

1. Speed Control

The conveyor speed control knob may be located remote to the control panel. Sometimes it is located behind a hinged door. There is only one (1) speed control knob per conveyor.

2. Conveyor Stop Switch

The red, conveyor Stop switch may be located remote to the control panel. There may be more than one (1) Stop switch. Pressing any one of the Stop switches will cause the conveyor to stop immediately. Some conveyors are equipped with a large, red, mushroom-shaped Stop switch that is easier for users to operate.

3. Conveyor Start Switch

A conveyor may be equipped with a green Start switch that is located remote to the Conveyor Control Panel. A conveyor may have more than one Start switch. Pressing any Start switch will cause the conveyor belt to go into motion.

4. Momentary Switch

Some conveyors may be equipped with a momentary contact conveyor run switch, remote of the conveyor control panel. If the conveyor is off, pressing the black Momentary Switch will cause the conveyor to run for as long as the switch is held in. If the conveyor is running, it will continue to run for as long as the black, Momentary Switch is depressed, then stop as soon as it is released.

D. End Switches (Optional)

1. Limit Switch

A limit switch may be provided with the conveyor. When activated, the limit switch will momentarily stop the conveyor. The conveyor will continue to run as soon as the obstruction is removed.

a. Photocell Beam Type

The photocell, beam type switch uses a polarized, reflected beam of light to determine when an object has reached the end of the conveyor. When the beam of light is interrupted, the conveyor stops. When the obstruction is removed, the conveyor continues.

b. Arm Switch Type

A flexible, movable arm actuator attached to an electrical switch may be mounted in the back splash of the conveyor bed. When an object moves the arm, the conveyor stops momentarily. When the object is removed, the conveyor continues to run.

c. Pressure Type

A flat plate located at the end of the of the belt is attached to an electrical switch mounted at the end of the conveyor bed on the tank. When an object moves the plate, the conveyor stops momentarily. When the object is removed, the conveyor continues to run.

2. Anti-Jam Switch

The conveyor may be equipped with a flip-up anti-jam cover plate mounted at the drive end. When an object becomes wedged between the belt and the cover plate, the cover plate pivots up and causes the conveyor belt to stop. The conveyor will not restart until the anti-jam cover plate is returned to its normal running position and the Start switch is pressed. A magnet is provided inside the anti-jam cover plate to catch flatware before it falls into the drive compartment.

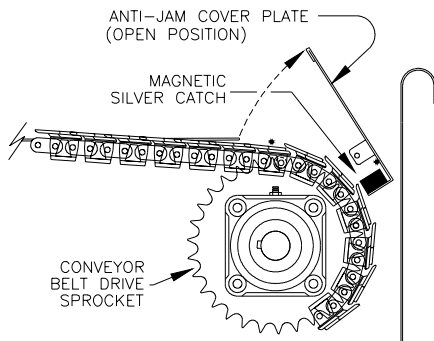

Fig. 4.7

E. Motor Control Adjustments

See Minarik Motor Master MM23000 adjustable speed motor booklet or contact AVTEC IND.

V. MAINTENANCE

A. Cleaning

It is important that the AVTEC conveyor is kept clean in order to avoid unsanitary conditions. It has been designed with ease of cleaning in mind. It is recommended that the electrical power to the conveyor be turned off or disconnected while being cleaned. **NOTE: DO NOT** use steel wool or any other abrasive pad on the conveyor surface.

DO NOT spray the conveyor controls directly with a hose.

1. Drip Pan - for Hinge Type Belt

Standard drip pans are accessible from the side of the conveyor and should be routinely cleaned. **Note: DO NOT operate conveyor when drip pan is in the down position.**

2. Drip Pan for Chain Type Belt

These drain pans are located about 1/4" from the return belt. If provided with the flush feature, they need not be cleaned under normal operating conditions. The drip pan

may be lowered for cleaning or replacing the belt.

To lower the drip pan:

Holding the drip pan with hand to relieve the pressure, release the catch by sliding the lock upwards, as shown, allowing the latching bracket to rotate down.

To return drip pan to upper position:

Holding the drip pan in upper position, rotate the latching bracket to the upper position, latching bracket will self-lock [See fig. 5.1].

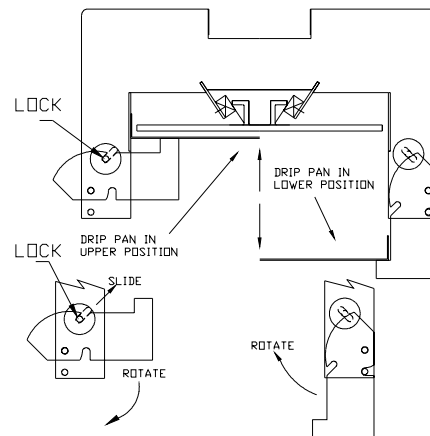

Fig. 5.1

3. External Scrap Basket (Tank)

Conveyors equipped with the optional belt wash/flush have a scrap basket to prevent drain blockage. This scrap basket requires periodic removal to empty its contents. The basket is located externally at the base of the tank. [See fig. 5.2].

To remove:

1. Turn off the conveyor
2. Simply slide the scrap basket out of chute.
3. Reverse steps to install.

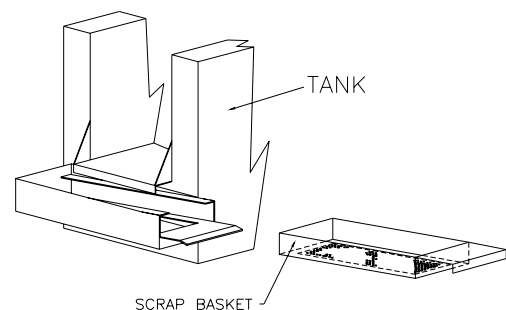

Fig. 5.2

4. External Scrap Basket (Tail)

Conveyors equipped with optional drip pan flush have a scrap basket to prevent drain blockage. This scrap basket requires periodic removal to empty its contents. The basket is located externally at the base of the tail end sprocket support bracket. [See fig. 5.3].

To remove:

1. Turn off conveyor
2. Simply slide scrap basket out of chute.
3. Reverse steps to install.

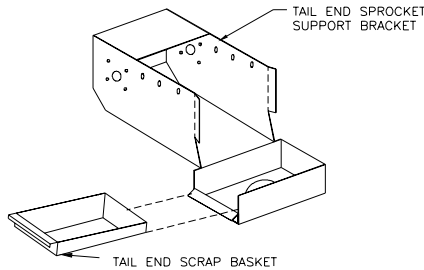

Fig. 5.3

5. Wear Strip

In order to allow thorough cleaning of the slider bed, the upper straight and outer corner sections of wear strips can be lifted. Lift belt out of the bed to access wear strip. To lift belt from corner sections, slide belt upwards and away from the center. Reverse operation to insert. [See fig. 5.4].

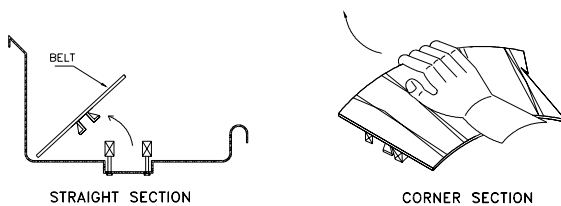

Fig. 5.4

B. Detergent Wash and Flush

AVTEC recommends EVAC Detergent for use in the conveyor system. It generally is effective in water at temperature between 40°F and 140°F (Must be minimum 70°F if sanitization is required. Note: A lubricating type detergent is not required for proper belt operation). Detergent Housing, if supplied (see Fig 5.7); otherwise the pump is mounted in the drive housing and a 5 ft tube with foot valve supplied for insertion into your detergent bottle (tank).

C. Access for Servicing

1. Hinged Side Panel

For most conveyors, access to the lower section requires simply swinging the panels up. The panels remain in the up position until lowered.

[See fig. 5.5A].

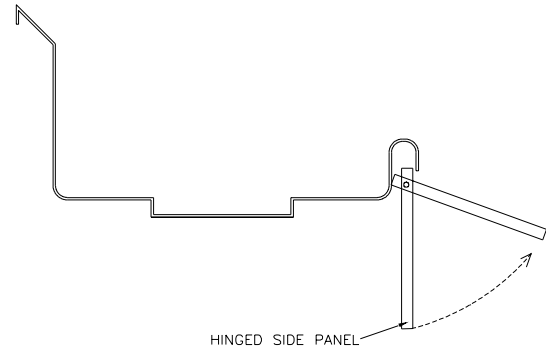

Fig. 5.5A

2. Removable Side Panel (Tray Make-up Only)

Access to the lower section requires removing the side panels. To remove the side panel, lift up the panel past the retaining tab, and slide out in downward and outward direction. [See fig. 5.5B].

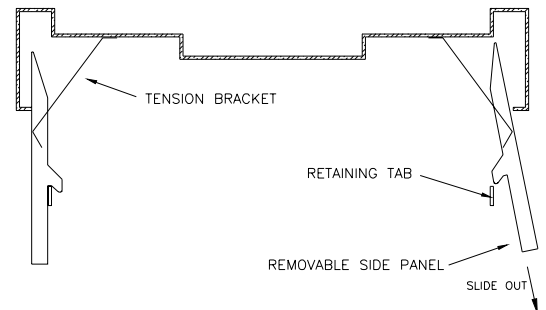

Fig. 5.5B

3. Access Plate

Conveyors equipped with the optional belt wash/rinse feature and an external scrap basket, have a plate that is removable (with tools) on the side of the tank to facilitate access to the bearings, sprocket, shaft and plumbing. Turn off all power to the conveyor before removing the access plate. [See fig. 5.6].

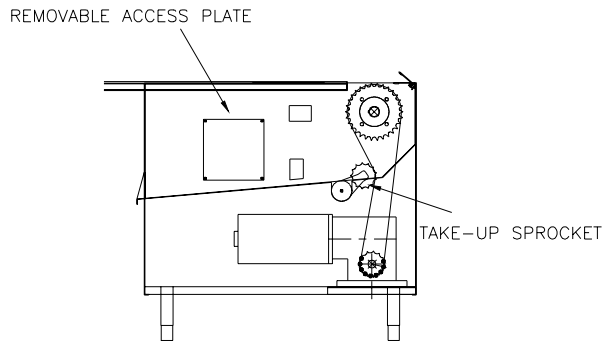

Fig. 5.6

4. Remote Detergent Housing (Optional)

The remote detergent housing is typically located under the trough to facilitate refilling and priming of detergent. To prime pump depress prime pump switch until fluid is seen flowing through pump. If pump does not prime due to air in line, remove upper discharge detergent line and prime pump. Set stroke of pump with adjustment knob located on pump. Use a detergent with a disinfecting agent. (WEAR PROTECTIVE EYE GEAR).

[See fig. 5.7]

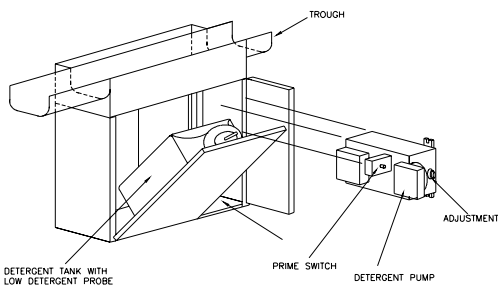

Fig. 5.7

5. Drive Housing

The standard housing is equipped with side panels that are removable (with tools) for access to sprockets, chain, motor and gear box. The conveyor must be turned off before the panels are removed.

Double hinged, double pan doors are available as an option.

An optional interlock switch will prevent the conveyor from running when a panel or door is opened.

[See fig. 5.8].

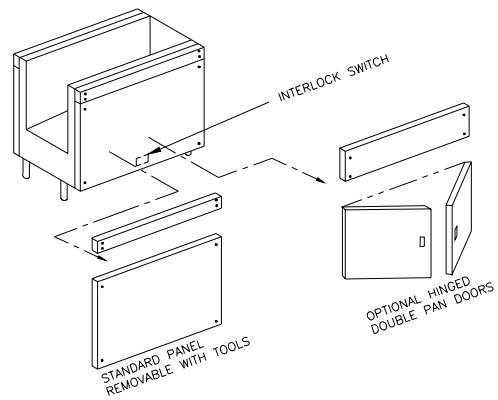

Fig. 5.8

6. Beam Switch

The beam switch is an optional feature designed to stop the conveyor as items reach a certain location or are being stacked up at the end of the conveyor. To service this unit, turn off conveyor and access the switch by removing the screws (or nuts) and switch housing. Reverse steps to re-assemble. [See Fig. 5.9 - 5.10]

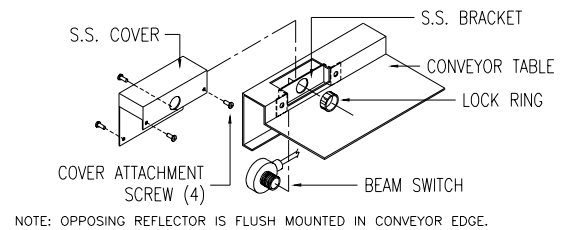

Fig. 5.9

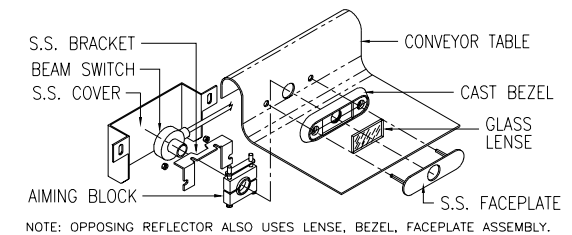

Fig. 5.10

D. Routine Servicing

1. Gear Box

- The gearbox is lubricated for life, overhaul is required to change oil.

2. Belt

- Visually inspect every month for wear, chips, scratches, cracks or signs of misalignment.

3. Intermediate Drive Chain

- Lubricate the Intermediate Drive Chain [which runs from the gearbox to the belt drive sprocket] after one [1] month of operation.
- Lubricate after four [4] months of operation thereafter.
- Recommended Lubricant:
Roller Chain Lubricant
McMaster-Carr No. 6159 K11 or equivalent.

VI. PARTS LIST

A. BELT (CI SERIES)

ITEM NO.	AVTEC PART NO.	DESCRIPTION
1	120-5022	10" w Interlocking Assembly (Grey)

B. BELT (CB SERIES)

ITEM NO.	AVTEC PART NO.	DESCRIPTION
1	120-5200	Chain
2	120-5150	10" w Replacement Slat (Black)

C. WEAR STRIP

ITEM NO.	AVTEC PART NO.	DESCRIPTION
1	120-6025	3/4" x 1-1/8" (CI/CB Series)
2	120-6026	1/2" x 3/4" (CB Series)
3		Upper/Outer Radius (CB)
3a	120-6901	18" Radius
3b	120-6905	24" Radius
3c	120-6909	28 1/2" Radius
4		Upper/Inner Radius (CB)
4a	120-6900	18" Radius
4b	120-6904	24" Radius
4c	120-6908	28 1/2" Radius
5		Lower/Outer Radius (CB)
5a	120-6903	18" Radius
5b	120-6907	24" Radius
5c	120-6911	28 1/2" Radius
6		Lower/Inner Radius (CB)
6a	120-6902	18" Radius
6b	120-6906	24" Radius
6c	120-6910	28 1/2" Radius

D. BELT SPROCKET

ITEM NO.	AVTEC PART NO.	DESCRIPTION
1	300-0052	Drive End (CI Series)
2	300-0027	Tail End (CI Series)
3	300-0050	Drive/Tail (CB Series)

E. INTERMEDIATE DRIVE

ITEM NO.	AVTEC PART NO.	DESCRIPTION
1	300-0022	Reducer Sprocket (15T)
2	300-0053	Shaft Sprocket (25T)
3	301-0002	Chain (Drive #50)
4	301-0005	Master Link (#50 Chain)

F. BEARINGS (Wash Tank Drive)

ITEM NO.	AVTEC PART NO.	DESCRIPTION
1	303-0009	1" Dia. Bearing
2	303-0014	1 1/4" Dia. Sealed Bearing
2		(Black)

G. DRIVE HOUSING

ITEM NO.	AVTEC PART NO.	DESCRIPTION
1	407-1449	Interlock Switch (Door)
2		Motor
2a	420-0008	1/2" HP Motor
2b	420-0009	3/4" HP Motor
2c	420-0014	1 HP Motor
3		Reducer
3a	305-0000	Reducer - LH 1/2-3/4 HP Motor
3b	305-0001	Reducer - RH 1/2-3/4 HP Motor
3c	Special Order	Reducer - 1 HP Motor
4a	420-0002	Brushes - 1/2-3/4 HP Motor
4b	420-0003	Brushes - 1 HP Motor
5	407-1381	Hour Meter
6	600-1100	Check Valve
7	407-1101	Solenoid Water 1/2"

H1. CONTROL BOX (Wash/Flush)

ITEM NO.	AVTEC PART NO.	DESCRIPTION
1	420-0000	Motor Control Board (MCB)
2	407-1400	Flushtimer (TIMER 1)
3	407-1400	Washtimer (TIMER 2)
4	407-0018	Pot 1. Flush
5	407-0018	Pot 2. Wash
6	407-1470	Wash/Flush Timer for units shipped after 10/01/98
7	407-0020	Speed Control (10K Pot)
8	405-1093	Start Switch (Green) w / N.O. contact
9	405-1094	Stop Switch (Red) w / N.C. contact
10	405-1095	Wash Switch (Blue)
11	407-1270	Power Relay (RY1)
12	407-1278	Limit Switch Relay (RY2)
13	407-1271	Flush Relay (RY3)
14	407-1271	Wash Relay (RY4)
15	407-1271	Det Pump Relay (RY5)
16	206-0005	15 Amp Main Fuse
17	405-1096	Contact Block N.O.
18	405-1097	Contact Block N.C.
19	407-1252	Level Sensor (LSB)
20	406-8031	Disconnect Switch (DS)

H2. CONTROL BOX (Wash Only)

ITEM NO.	AVTEC PART NO.	DESCRIPTION
1	420-0000	Motor Control Board (MCB)
2	407-1462	Washtimer (TIMER 1)
3	407-0018	Pot 1. Wash
4	407-0020	Speed Control (10K Pot)
5	405-1093	Start Switch (Green) w / N.O. contact
6	405-1094	Stop Switch (Red) w / N.C. contact
7	405-1095	Wash Switch (Blue)
8	407-1270	Power Relay (RY1)
9	407-1278	Limit Switch Relay (RY2)
10	407-1295	Flush Relay (RY3)
11	206-0005, 206-0022	15 Amp Main Fuse, 10 Amp Fuse
12	405-1096	Contact Block N.O.
13	405-1097	Contact Block N.C.
14	407-1252	Level Sensor (LSB)
15	406-8031	Disconnect Switch (DS)

I. DETERGENT UNIT

ITEM NO.	AVTEC PART NO.	DESCRIPTION
1	490-1172	Detergent Probe
2	602-2001	Detergent Pump
3	407-1450	Pump Prime Switch
4	602-3001	EVAC Detergent case of 4-1gal

J. END OF CONVEYOR

ITEM NO.	AVTEC PART NO.	DESCRIPTION
1	405-1209	Reflector, 1" dia.
2	405-1227	Anti-Jam Switch, 405-1227 used for both the anti-jam and wand-type.
3	405-1210	Beam Switch
4	405-1225	Pressure Type Micro Switch
5	405-1227	Lever (Wand) Type Limit Switch

K. OTHER

ITEM NO.	AVTEC PART NO.	DESCRIPTION
1	130-0008	Return Rollers
2	602-2002	Pump Head Repair Kit
3	130-0006	Skate Wheel
4	130-0008	10" Roller w/Shaft

L. FLUSH SYSTEM

ITEM NO.	AVTEC PART NO.	DESCRIPTION
1	600-0315	Flush Pressure Valve
2	609-0013	Male Adapter
3	609-0014	90° Male Adapter
4	609-0015	1/2 ID PVC Braid Tubing
5	609-0016	1/2 ID Union for PVC Tube