

TAKU Premier Ventilation External MUA Cartridge model AXWO-P

Description:

This low volume exhaust only canopy is UL 710 listed over 400, 600, and 700°F cooking surface temperatures. The AXWO-P hood is a make-up air canopy which has an extraction method through a custom grease extracting 6-pass dry cartridge. The perforated supply air plenum can be shipped attached to the hood, or shipped loose to suit on-site job specific requirements. The front supply air plenum can provide up to 80% make up air.

AX hoods are intended for use over all types of commercial cooking equipment. Available in wall or island style configuration, the extractor cartridges are easily removable for cleaning. This model is recommended for all projects where higher grease extraction efficiencies are desired.

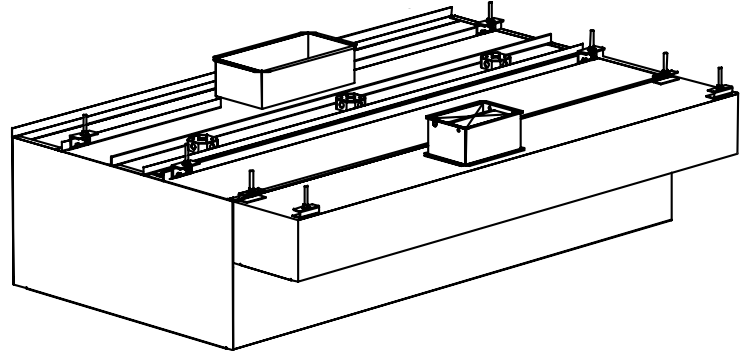

Specifications:

Exhaust only Type I commercial kitchen ventilation canopy UL 710 Listed with or without an exhaust fire damper. Canopy is constructed of a minimum 18 gauge non-magnetic stainless steel on all surfaces. All exterior joints and seams shall be continuously welded liquid tight, ground smooth, and polished to match the finish requirements. Canopy ends shall be double side wall construction. Construction to conform to NFPA 96 standards and shall meet UL 710 standards for operation. Canopy is constructed using the standing seam method for optimum strength. Removable stainless steel 6-pass grease extractor modules running full length of canopy and made easily removable for cleaning. Grease trough is concealed within the hood and slopes to a removable grease cup located at the end of the canopy. Canopy comes complete with UL Listed incandescent globe style light fixtures mounted on 36" center lines. Make-up air is introduced to the kitchen via a fully insulated ceiling mounted supply air plenum with stainless steel perforated discharge panels and with internal air diffusers to provide an even flow of air across the length of the hood. Make-up air collar(s) shall include air volume control damper.

Standard Features:

- Heavy gauge non-magnetic stainless steel construction
- UL Listed incandescent globe light fixtures mounted on 36" center lines
- 3" Rear air space
- Full length concealed grease trough
- Pre-drilled hanger brackets
- UL Listed 6 pass dry cartridge style grease extractors
- Concealed grease trough sloped to a removable grease cup
- Insulated ceiling mounted supply air plenum

Optional Accessories:

- 14" Wide utility cabinet mounted on end of hood
- Electrical control panel
- Pre-plumbed fire suppression
- Insulated 3" air space for 0" clearance to combustibles
- Stainless steel top enclosures
- Fan/light switches
- UL Listed recessed incandescent or recessed fluorescent light fixtures
- Stainless steel wall panel
- Stainless steel side skirts
- Continuous cold water mist to aid in grease extraction
- Melink Intelli-Hood® system controls
- Exhaust fan / cooking equipment interlock control
- Sloped front design for low ceiling application
- UL Listed exhaust volume damper available on all models with (2) exhaust collars

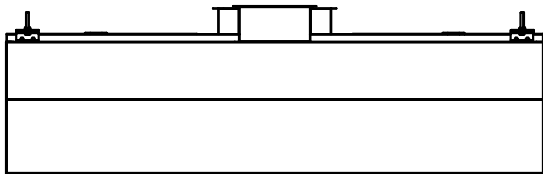
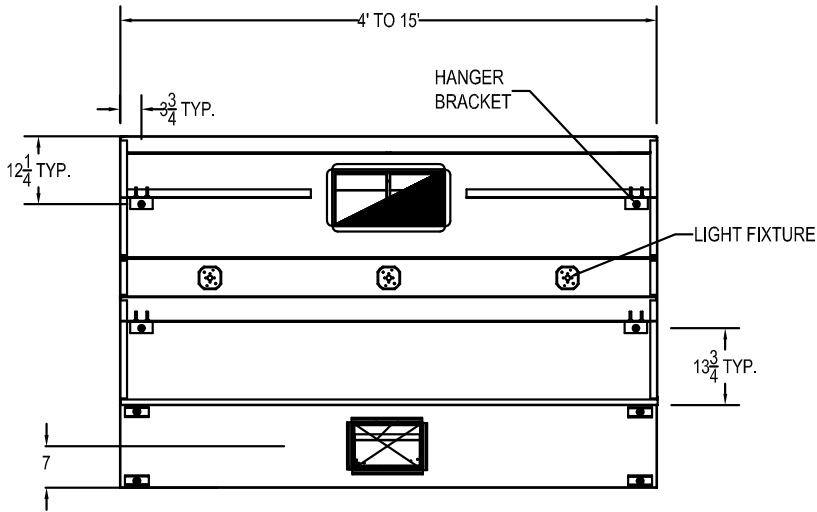

6" MINIMUM OVERHANG REQUIRED (TYP.)

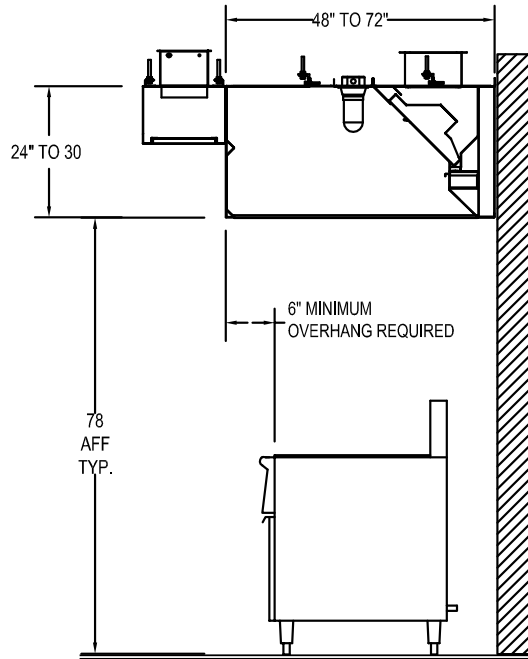
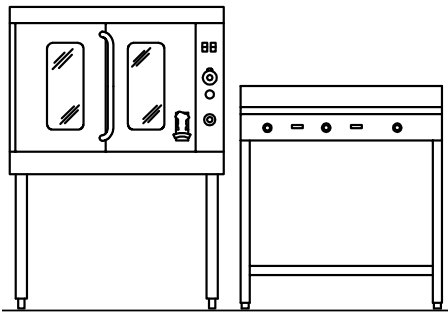

UMC

IMC

NFPA-96





Model AXWO-P

Light Duty Temperature Cooking Equipment – 400°F
 Light duty ranges, roasters, ovens, steamers, etc...
 Medium Duty Temperature Cooking Equipment – 400-600°F
 Rotisseries, ranges, grills, fryers, etc...
 High Temperature Cooking Equipment – 600°F
 Gas char-broilers, woks, upright broilers, etc...
 Extra-Heavy Temperature Cooking Equipment – 700°F
 Solid fuel broilers

Length	400 Degree Light Duty Cooking Equipment Exhaust CFM		400-600 Degree Medium Duty Cooking Equipment Exhaust CFM		600 Degree Heavy Duty Cooking Equipment Exhaust CFM		700 Degree Extra-Heavy Duty Cooking Equipment Exhaust CFM	
	CFM @ 1.30 SP	Duct Collar	CFM @ 1.65" SP	Duct Collar	CFM @ 1.75"SP	Duct Collar	CFM @ 1.90"SP	Duct Collar
4'-0"	1000	8 x 12	1200	8 x 14	1400	8 x 16	2100	8 x 24
5'-0"	1250	8 x 14	1500	8 x 16	1750	8 x 20	2625	10 x 24
6'-0"	1500	8 x 16	1800	8 x 20	2100	8 x 24	3150	10 x 28
7'-0"	1750	8 x 20	2100	8 x 24	2450	8 x 28	3675	10 x 34
8'-0"	2000	8 x 22	2400	8 x 28	2800	10 x 24	4200	12 x 32
9'-0"	2250	8 x 26	2700	10 x 24	3150	10 x 28	4725	12 x 36
10'-0"	2500	8 x 28	3000	10 x 28	3500	12 x 26	5250	12 x 40
11'-0"	2750	10 x 24	3300	12 x 24	3850	12 x 30	5775	12 x 44
12'-0"	3000	10 x 28	3600	12 x 28	4200	12 x 32	6300	2-12 x 24
13'-0"	3250	12 x 24	3900	12 x 30	4550	12 x 34	6825	2- 12 x 26
14'-0"	3500	12 x 26	4200	12 x 32	4900	12 x 36	7350	2- 12 x 28
15'-0"	3750	12 x 28	4500	12 x 34	5250	12 x 40	7875	2- 12 x 30
16'-0"	4000	2-10 x 18	4800	2- 10 x 22	5600	2-10 x 24	8400	2- 12 x 32

Length	Light Duty Supply CFM		Medium Duty Supply CFM		Heavy Duty Supply CFM		Extra-Heavy Duty Supply CFM	
	CFM @ .25 SP	Duct Collar	CFM @ .385" SP	Duct Collar	CFM @ .50"SP	Duct Collar	CFM @ .65"SP	Duct Collar
4'-0"	800	12 x 12	960	10 x 20	1120	10 x 20	1680	12 x 24
5'-0"	1000	10 x 20	1200	10 x 20	1400	10 x 30	2100	12 x 24
6'-0"	1200	10 x 20	1440	10 x 30	1680	12 x 24	2520	10 x 40
7'-0"	1400	10 x 30	1680	12 x 24	1960	10 x 40	2940	10 x 40
8'-0"	1600	12 x 24	1920	10 x 40	2240	2-10 x 20	3360	2-10 x 30
9'-0"	1800	10 x 40	2160	10 x 40	2520	2-10 x 20	3780	2-10 x 40
10'-0"	2000	10 x 40	2400	2-10 x 20	2800	2-10 x 30	4200	2-10 x 40
11'-0"	2200	2-10 x 20	2640	2-10 x 30	3080	2-10 x 30	4620	2-10 x 40
12'-0"	2400	2-10 x 20	2880	2-10 x 30	3360	2-12 x 24	5040	2-10 x 40
13'-0"	2600	2-10 x 30	3120	2-12 x 24	3640	2-10 x 40	5460	2-10 x 40
14'-0"	2800	2-10 x 30	3360	2-12 x 24	3920	2-10 x 40	5880	2-10 x 40
15'-0"	3000	2-12 x 24	3600	2-10 x 40	4200	2-10 x 40	6300	2-10 x 40
16'-0"	3200	2-12 x 24	3840	2-10 x 40	4480	2-10 x 40	6720	2-10 x 40

Note: Greater exhaust and/or lesser supply air flow rates may be required for each specific installation to obtain complete vapor and smoke removal.
 Note: Hoods over 15'-0" in length require two exhaust duct collars. Exhaust collar sizing is based on an average range of 1600FPM. Duct collars are located on centerline of canopy, unless otherwise specified. Hoods with double collars have them located on ¼ hood length lines unless otherwise specified.
 Canopy is to have a minimum 6" overhang on all exposed sides and the front leading edge to the perimeter of cooking surface.

UMC

IMC

NFPA-96



1055 Mendell Davis Drive, Jackson, MS 39272, 888-994-7636, unifiedbrands.net
 © 2009 Unified Brands. All Rights Reserved. DOVER® and the DOVER® Logo are registered trademarks in the United States [and various other countries] of Unified Brands, a wholly-owned subsidiary of Dover Corporation.

Packaging - Processing
Bid on Equipment
 1-847-683-7720
www.bid-on-equipment.com