

# TAKU Premier Ventilation Exhaust Only Cartridge model AXWO

## Description:

The AXWO hood is an exhaust only canopy whose extraction method is through a custom grease extracting 6-pass dry cartridge.

This low volume exhaust only canopy is UL 710 Listed for use over 400, 600, and 700°F cooking surface temperatures. AX hoods are intended for use over all types of commercial cooking appliances. Available in a wall or island style configuration. The extractor cartridges are easily removable for cleaning. This model is recommended for all projects where higher grease extraction efficiencies are desired.

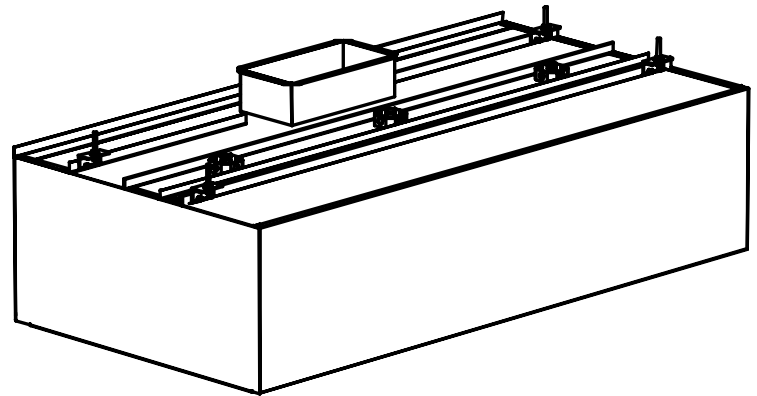

## Specifications:

Exhaust only Type I commercial kitchen ventilation canopy UL 710 Listed with or without an exhaust fire damper. Canopy is constructed of minimum 18 gauge non-magnetic stainless steel on all surfaces. All exterior joints and seams shall be continuously welded liquid tight, ground smooth, and polished to match the finish requirements. Canopy ends shall be double side wall construction. Construction to conform to NFPA 96 standards and shall meet UL 710 standards for operation. Canopy is constructed using the standing seam method for optimum strength. Removable stainless steel 6-pass grease extractor modules running full length of canopy. Grease trough is concealed within the hood and slopes to a removable grease cup(s) located at the end of the canopy. Canopy comes complete with UL Listed incandescent light fixtures on 36" centers.

## Standard Features:

- Heavy gauge non-magnetic stainless steel construction
- UL Listed incandescent light fixtures mounted on 36" centerlines
- 3" Rear air space
- Full length concealed grease trough
- Pre-drilled hanger brackets
- UL Listed 6-pass dry cartridge style grease extractors
- Concealed grease trough sloped to a removable grease cup

## Optional Accessories:

- Utility cabinet mounted on end of hood
- Electrical control panel
- Pre-plumbed fire suppression
- Insulated 3" air space for 0" clearance to combustibles
- Stainless steel top enclosures
- Light switch
- Fan/light switch
- UL Listed recessed incandescent or recessed fluorescent light fixtures
- Stainless steel wall panel
- Stainless steel side skirts
- Grease extractor removal tool
- Melink Intelli-Hood® control systems
- Exhaust fan / cooking equipment interlock control
- Sloped front design for low ceiling application
- UL Listed exhaust volume damper available on all models with (2) exhaust collars

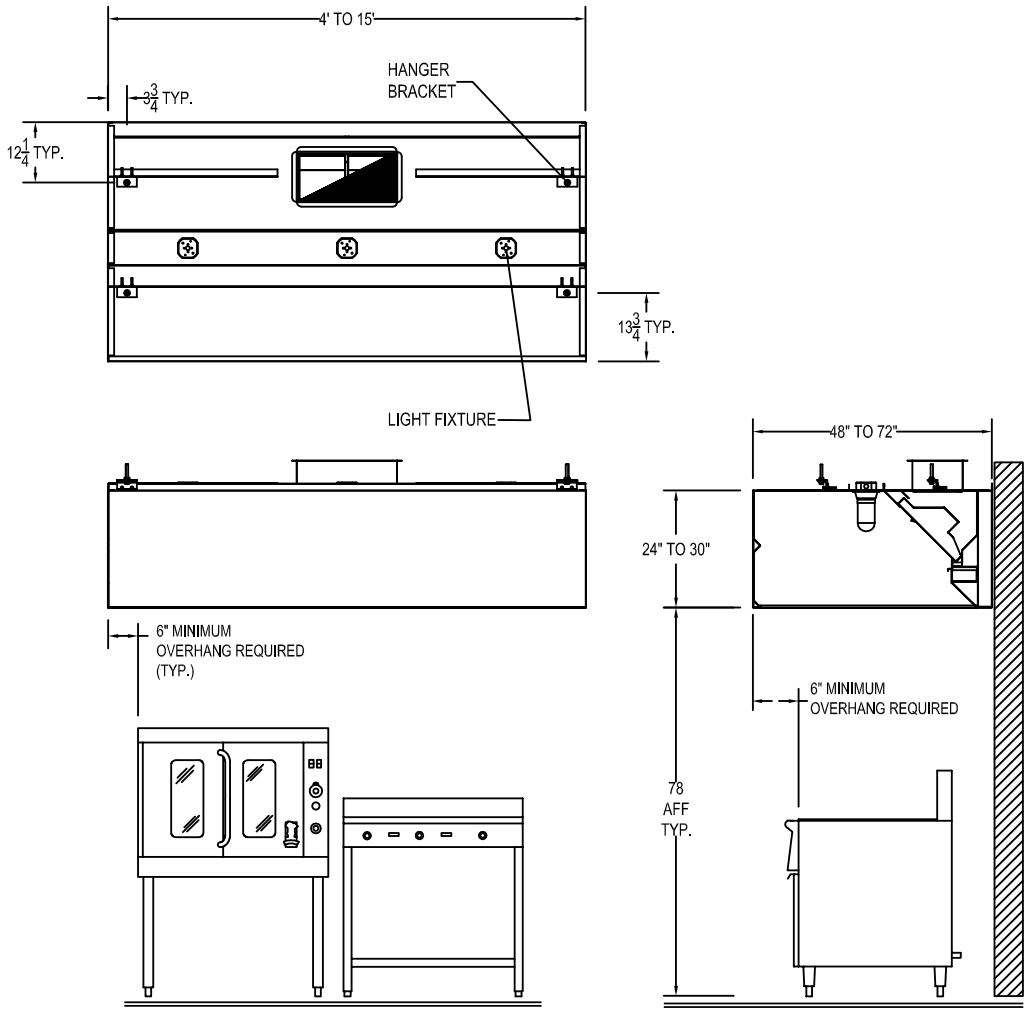

**Light Duty Temperature Cooking Equipment – 400°F**  
 Light duty ranges, roasters, ovens, steamers, etc...  
**Medium Duty Temperature Cooking Equipment – 400-600°F**  
 Rotisseries, ranges, grills, fryers, etc...  
**Heavy Duty Temperature Cooking Equipment – 600°F**  
 Gas char-broilers, woks, upright broilers, etc...  
**Extra-Heavy Temperature Cooking Equipment – 700°F**  
 Solid fuel broilers

Length	400 Degree Light Duty Cooking Equipment Exhaust CFM		400-600 Degree Medium Duty Cooking Equipment Exhaust CFM		600 Degree Heavy Duty Cooking Equipment Exhaust CFM		700 Degree Extra-Heavy Duty Cooking Equipment Exhaust CFM	
	CFM @ 1.30 SP	Duct Collar	CFM @ 1.65" SP	Duct Collar	CFM @ 1.75" SP	Duct Collar	CFM @ 1.90" SP	Duct Collar
4'-0"	1000	8 x 12	1200	8 x 14	1400	8 x 16	2100	8 x 24
5'-0"	1250	8 x 14	1500	8 x 16	1750	8 x 20	2625	10 x 24
6'-0"	1500	8 x 16	1800	8 x 20	2100	8 x 24	3150	10 x 28
7'-0"	1750	8 x 20	2100	8 x 24	2450	8 x 28	3675	10 x 34
8'-0"	2000	8 x 22	2400	8 x 28	2800	10 x 24	4200	12 x 32
9'-0"	2250	8 x 26	2700	10 x 24	3150	10 x 28	4725	12 x 36
10'-0"	2500	8 x 28	3000	10 x 28	3500	12 x 26	5250	12 x 40
11'-0"	2750	10 x 24	3300	12 x 24	3850	12 x 30	5775	12 x 44
12'-0"	3000	10 x 28	3600	12 x 28	4200	12 x 32	6300	2-12 x 24
13'-0"	3250	12 x 24	3900	12 x 30	4550	12 x 34	6825	2- 12 x 26
14'-0"	3500	12 x 26	4200	12 x 32	4900	12 x 36	7350	2- 12 x 28
15'-0"	3750	12 x 28	4500	12 x 34	5250	12 x 40	7875	2- 12 x 30
16'-0"	4000	2-10 x 18	4800	2- 10 x 22	5600	2-10 x 24	8400	2- 12 x 32

Note: Greater exhaust air flow rates may be required for each specific installation to obtain complete vapor and smoke removal.  
 Note: Hoods over 15'-0" in length require two exhaust duct collars. Exhaust collar sizing is based on an average range of 1600 FPM. Duct collars are located on centerline of canopy, unless otherwise specified. Hoods with double exhaust collars have them located on 1/4 hood length lines unless otherwise specified. Canopy is to have a minimum 6" overhang on all exposed sides and the front leading edge of canopy to perimeter edge of the cooking surface.

UMC

IMC

NFPA-96

