



# MP600

Touch-screen terminal with printer

Choose the MP600 when unlimited ingredients, nutri-facts, and label formats are necessary for non-weighed items. Whether the application is bakery counter, pre-pack or home meal replacement (HMR), the MP600 will deliver higher profits and return on investment and lower cost of ownership.

- Flexible label formats and unlimited logo capabilities eliminate the need for expensive, pre-printed labels.
- Ideal for non-weighed items.
- Easy-to-use touch screen technology.
- Easy integration with back office systems.



Ideal for bakery counter and pre-pack use, the MP600 efficiently prints labels for products that are sold by unit count rather than weight. Personalize labels with your store logo, various bar code formats and more. An external printer for large label printing is available, allowing easy packaging of store-branded products.

Touch screen technology and a user-friendly interface make the system easy to use. Training costs are minimized, as employees are able to learn the system quickly. Utilize Home Meal Replacement (HMR) features, allowing your employees to assemble unit items into a single meal combo for your customers. In self-service applications, customers can use the printer for pricing non-weighed items.

Avery Berkel works directly with chain store IT and Operations personnel to provide customized, fully integrated, networked applications. The MP software is versatile and can be customized to meet specific selling and management needs.

## Applications

- **Bakery department items**
- **Home Meal Replacement preparation and sale**
- **Non-weighed prepack operations**
- **Non-weighed self-service stations**
- **Large format label printing**  
(when combined with large label printers)
- **Recipe printing**

## Dimensions

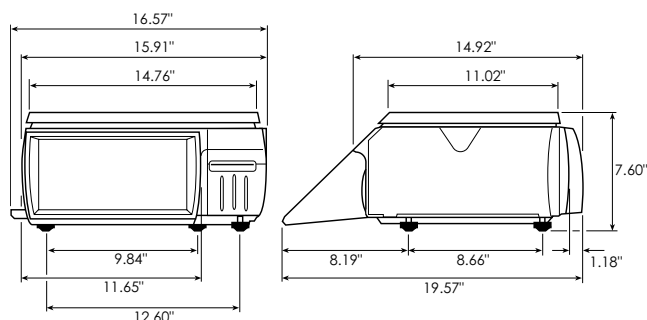

## Specifications

- **Fruit & Vegetable picture library available**
- **Processor**  
800 MHz
- **System Memory**  
128 MB SDRAM (expandable)  
32 MB video RAM
- **Operating System**  
Windows XP Embedded
- **Program and Data Storage**  
Standard 20 GB hard disk drive
- **Vendor Display**  
10.4" SVGA color TFT  
800 x 600 SVGA mode
- **Touch screen**  
Four wire resistive touch screen on vendor display
- **Interfaces**  
Two x 9 way D-type RS232 ports  
(5v DC power available)  
USB high-speed peripheral interface bus
- **Networking**  
10/100 base T Ethernet network (RJ45 socket)  
Standard Networking Protocol (SNMP)  
Email and text messaging
- **Options**  
Internal RF: 802.11b Wi-Fi compatible,  
internal speakers, external SVGA  
interface, cash drawer interface
- **Cassette Printer**  
*Type of printer:* Direct thermal  
*Cassette Loading:* 120 mm diameter roll  
*Label/Print width:* 65mm/59 mm  
*Print speed:* Up to 100 mm per second  
*Label formats:* Unlimited  
*Paper type:* Ricoh® 130 or equivalent  
Please refer to 'Thermal Label/Receipt  
Material Specification'  
*Diagnostics:* 'Code Checker' automatically  
detects and reports print head faults  
*Print head:* Special protection coating.  
Quick-change print head module
- **Agency Approvals**  
Legal for Trade, NTEP Class III  
USA COC# 01-010A2

Microsoft and Windows are either registered trademarks or trademarks of Microsoft Corporation in the United States and/or other countries.  
Ricoh is a registered trademark of Ricoh Company, Ltd.

Packaging - Processing

**Bid on Equipment**

1-847-683-7720

[www.bid-on-equipment.com](http://www.bid-on-equipment.com)

**Avery Berkel**

**Avery Weigh-Tronix  
(Retail North America)**

1758 Genesis Drive, Suite A  
LaPorte, IN 46350

**PH Toll-Free:** 800-237-1886

**PH:** 219-325-9587

**FAX Toll-Free:** 800-237-2063

**FAX:** 219-325-9594

**E-mail:** [sales@AveryBerkelUSA.com](mailto:sales@AveryBerkelUSA.com)

**Internet:** [www.AveryBerkelUSA.com](http://www.AveryBerkelUSA.com)



Product complies  
with F.C.C.