



MP300

Touch screen self-service scale

This self-service scale enables customers to weigh their own items and print labels for scanning during check out. The advantages: higher profits, reduced check-out times and increased customer satisfaction.

- Easy to use touch screen technology.
- Integrated weighing and label printing features.
- Simple integration with back room offices.
- Fully customizable software.
- Optional sound capability.



Packaging - Processing

Bid on Equipment

1-847-683-7720

www.bid-on-equipment.com

Avery Berkel's MP 300 is designed with the customer in mind. Reliable and easy to use, the touch screen scale will increase customer satisfaction by shortening checkout times and increase revenue through advertising and cross-merchandising.

PC-based technology enables easy product manipulation, custom menus, eye-catching graphics and promotions. Dynamically populate and manage menus based on best sellers. Promotions and advertising can be displayed during quiet times to attract customers to the scale or triggered when specific items are weighed.

Avery Berkel works directly with chain store IT and Operations personnel to provide customized, fully integrated, networked applications. The MP software is highly flexible and can be customized to meet specific selling and management needs.

Ideal Applications

- **Self Service – produce, buffet/salad bar**
- **Recipe Printing**
- **In-store promotions and advertisements**

Dimensions

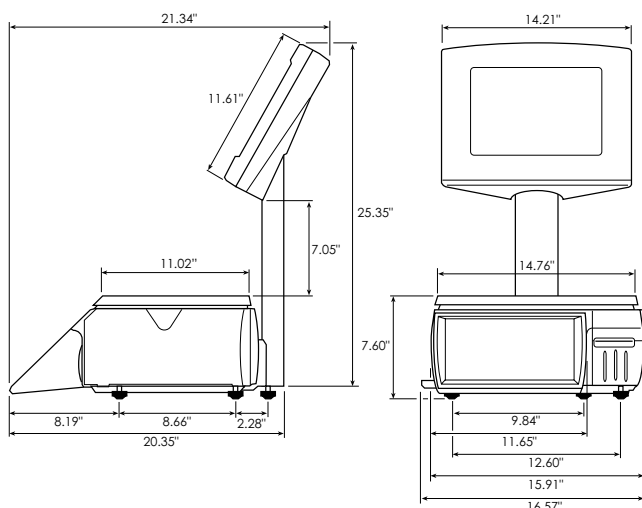

Specifications

- **Fruit & Vegetable picture library available.**
- **Weighing Capacity**
30 lb x 0.01 lb
- **Processor**
800 MHz Celeron class
- **System Memory**
128 MB SDRAM expandable to 256 MB
32 MB video RAM
- **Operating System**
Windows XP Embedded
- **Display**
12.1" SVGA color TFT
800 x 600 SVGA mode.
- **Program and Data Storage**
Standard 20 GB hard disk drive
- **Touch Screen**
Four wire resistive touch screen on vendor display
- **Interfaces**
Two x 9 way D-type RS232 ports
(5v DC power available)
USB high-speed peripheral interface bus
- **Networking**
10/100 base T Ethernet network (RJ45 socket)
- **Options**
Internal Speakers
External SVGA interface
Internal RF: 802.11b Wi-Fi compatible
Cash drawer interface
- **Cassette Printer**
Type of printer: Direct thermal
Cassette Loading: 120 mm diameter roll
Label/Print width: 60mm/59 mm
Print speed: Up to 100 mm per second
Label formats: Soft
Paper type: Ricoh 130 or equivalent.
Please refer to 'Thermal Label/Receipt Material Specification' sheet
Diagnostics: 'Code Checker' automatically detects and reports print head faults
Print head: Special protection coating.
Quick-change print head module
- **Agency Approvals**
Legal for Trade, NTEP Class III
USA COC# 01-010A2

Packaging - Processing
Bid on Equipment
1-847-683-7720
www.bid-on-equipment.com

Avery Berkel

**Avery Weigh-Tronix
(Retail North America)**
1758 Genesis Drive, Suite A
LaPorte, IN 46350

PH Toll-Free: 800-237-1886
PH: 219-325-9587
FAX Toll-Free: 800-237-2063
FAX: 219-325-9594

E-mail: sales@AveryBerkelUSA.com
Internet: www.AveryBerkelUSA.com



Product complies
with F.C.C.