



# MP200

Counter scale with tower display

Create the customer-clerk connection with the MP200. The tower displays product information, building customer confidence and return visits. The versatility and easy system integration of the MP200 will increase your return-on-investment and lower cost-of-ownership.

- On-screen messaging and promotion generate additional revenue
- User-friendly interface lowers training costs and builds employee confidence
- Our flexible label formats and unlimited logo capabilities eliminate the need for expensive, pre-printed labels.
- Simple integration with back-office systems allows for painless product maintenance



With its customer display tower, the MP200 scale is ideal for counter service applications. It can also be customized for a number of other applications if needed, ranging from pre-packaging to self-service.

The MP200 software can easily be configured for frequent shopper promotions or cross-merchandising. The scale can indicate volume price break levels of the product being weighed or suggest complimentary products. With the optional external SVGA interface, customers can view targeted promotions and advertising on an external monitor.

Avery Berkel works directly with chain store IT and Operations personnel to provide customized, fully integrated, networked applications. The MP software is highly flexible and can be customized to meet specific selling and management needs.

## Applications

- **Counter service**
- **Take home meal preparation and sale**
- **Prepack**
- **Large label and plastic deli card printing**  
(when combined with external and pentex-type card printers)
- **Recipe printing**

## Dimensions

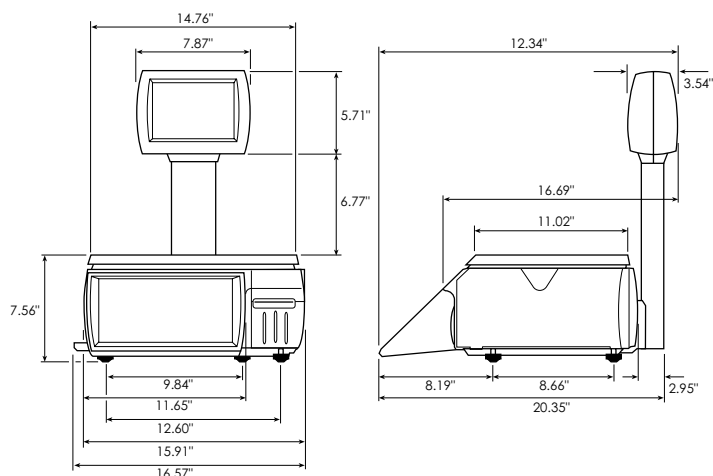

## Specifications

- **Fruit & Vegetable picture library available**
- **Weighing Capacity**  
30 lb x 0.01 lb
- **Processor**  
800 MHz
- **System Memory**  
128 MB SDRAM (expandable)  
32 MB video RAM
- **Operating System**  
Microsoft® Windows® XP
- **Program and Data Storage**  
Standard 20 GB hard disk drive
- **Vendor Display**  
10.4" SVGA color TFT  
800 x 600 SVGA mode
- **Customer Display**  
Counter level alphanumeric LCD display tower  
Variable contrast and backlight
- **Touch screen**  
Four wire resistive touch screen on vendor display
- **Interfaces**  
Two x 9 way D-type RS232 ports  
(5v DC power available)  
USB high-speed peripheral interface bus
- **Networking**  
10/100 base T Ethernet network (RJ45 socket)  
Standard Networking Protocol (SNMP)  
Email and text messaging
- **Options**  
Internal RF: 802.11b Wi-Fi compatible,  
internal speakers, external SVGA  
interface, cash drawer interface
- **Cassette Printer**  
*Type of printer:* Direct thermal  
*Cassette Loading:* 120 mm diameter roll  
Label/Print width: 65mm/59 mm  
Print speed: Up to 100 mm per second  
Label formats: Unlimited  
*Paper type:* Ricoh® 130 or equivalent  
Please refer to 'Thermal Label/Receipt  
Material Specification'  
*Diagnostics:* 'Code Checker' automatically  
detects and reports print head faults  
*Print head:* Special protection coating.  
Quick-change print head module
- **Agency Approvals**  
Legal for Trade, NTEP Class III  
USA COC# 01-010A2

Microsoft and Windows are either registered trademarks or trademarks of Microsoft Corporation in the United States and/or other countries.  
Ricoh is a registered trademark of Ricoh Company, Ltd.

Packaging - Processing

**Bid on Equipment**

1-847-683-7720

[www.bid-on-equipment.com](http://www.bid-on-equipment.com)

**Avery Berkel**

**Avery Weigh-Tronix  
(Retail North America)**

1758 Genesis Drive, Suite A  
LaPorte, IN 46350

**PH Toll-Free:** 800-237-1886

**PH:** 219-325-9587

**FAX Toll-Free:** 800-237-2063

**FAX:** 219-325-9594

**E-mail:** [sales@AveryBerkelUSA.com](mailto:sales@AveryBerkelUSA.com)

**Internet:** [www.AveryBerkelUSA.com](http://www.AveryBerkelUSA.com)



Product complies  
with F.C.C.