



# MP101

## Self-service touch-screen scale

Improve customer service and loyalty with the MP101. Increase returns on your investment and lower your total cost-of-ownership with faster checkout times and maintenance-free operation. Customer satisfaction grows with user friendly touch-screens and the reliability of Microsoft® Windows® XP.

- **Features:** automatic best sellers, auto keyboard generation and zero-maintenance make new product integration a snap.
- **Customer satisfaction:** custom screens, promotions and advertising enhance customers' overall experience.
- **Efficiency:** shorten checkout times and increase throughput with self-scanning and portable shopping system solutions.
- **Lower Costs:** fast internal cassette printer and custom labels eliminate need for special, pre-printed stock.
- **Versatility:** use the scale for self-service or pre-pack operations.



**Packaging - Processing  
Bid on Equipment**  
1-847-683-7720  
[www.bid-on-equipment.com](http://www.bid-on-equipment.com)

**A**very Berkel's MP101 makes self-service tasks quick and easy for your customers – increasing their shopping satisfaction and speeding up checkout times. The touch-screen display with user-friendly interface encourages customer interaction. To attract customer attention, advertisements and promotions can be displayed on the standard front display or on an external monitor with the SVGA interface option. Voice prompting can also be used with optional speakers.

Dynamic menu generation based on best sellers, multiple label formats and multiple operator modes make self-service and pre-pack a snap. Use your current back-office system or set up one scale as a server to allow product and data consistency throughout your store. PLU searches allow your customers and employees to be efficient and find products quickly.

Avery Berkel works directly with chain store IT and Operations personnel to provide customized, fully integrated, networked applications. The MP software is highly flexible and can be customized to meet specific selling and management needs.

## Applications

- **Self Service** – produce, bulk foods, bakery items
- **Recipe printing**
- **In-store promotion and advertisements**
- **Pre-packaging operations**

## Dimensions

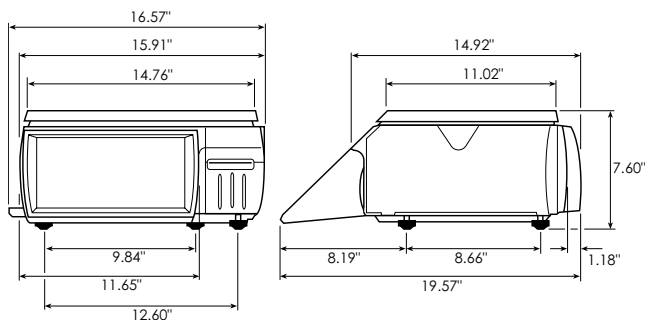

## Specifications

- **Fruit & Vegetable picture library available**
- **Weighing Capacity**  
30 lb x 0.01 lb
- **Processor**  
800 MHz
- **System Memory**  
128 MB SDRAM (expandable)  
32 MB video RAM
- **Operating System**  
Microsoft Windows XP
- **Program and Data Storage**  
Standard 20 GB hard disk drive
- **Vendor Display**  
10.4" SVGA color TFT  
800 x 600 SVGA mode
- **Touch screen**  
Four wire resistive touch screen on vendor display
- **Interfaces**  
Two x 9 way D-type RS232 ports  
(5v DC power available)  
USB high-speed peripheral interface bus
- **Networking**  
10/100 base T Ethernet network (RJ45 socket)  
Standard Networking Protocol (SNMP)  
Email and text messaging
- **Options**  
Internal RF: 802.11b Wi-Fi compatible,  
internal speakers, external SVGA  
interface, cash drawer interface
- **Cassette Printer**  
*Type of printer:* Direct thermal  
*Cassette Loading:* 120 mm diameter roll  
Label/Print width: 65mm/59 mm  
Print speed: Up to 100 mm per second  
Label formats: Unlimited  
*Paper type:* Ricoh® 130 or equivalent  
Please refer to 'Thermal Label/Receipt  
Material Specification'  
*Diagnostics:* 'Code Checker' automatically  
detects and reports print head faults  
*Print head:* Special protection coating,  
Quick-change print head module
- **Agency Approvals**  
Legal for Trade, NTEP Class III  
USA COC# 01-010A2

Microsoft and Windows are either registered trademarks or trademarks of Microsoft Corporation in the United States and/or other countries.  
Ricoh is a registered trademark of Ricoh Company, Ltd.

**Packaging - Processing**  
**Bid on Equipment**  
**1-847-683-7720**  
**www.bid-on-equipment.com**

**Avery Berkel**

**Avery Weigh-Tronix  
(Retail North America)**  
1758 Genesis Drive, Suite A  
LaPorte, IN 46350

**PH Toll-Free:** 800-237-1886  
**PH:** 219-325-9587  
**FAX Toll-Free:** 800-237-2063  
**FAX:** 219-325-9594



Product complies  
with F.C.C.

**E-mail:** sales@AveryBerkelUSA.com  
**Internet:** www.AveryBerkelUSA.com