



MP100

PC-based touch-screen scale

Our most versatile scale, the MP100 offers a cassette printer, front mounted color SVGA touch screen and alphanumeric LCD customer display.

- Easy to use touchscreen lowers employee training costs.
- Do it your way: use the powerful standard software or customize the scale menu system to suit your needs.
- With optional SVGA interface, connect an external monitor for product promotions and advertising.
- Fast internal printer with custom label designs.
- Optional sound capability.



Packaging - Processing
Bid on Equipment
 1-847-683-7720
www.bid-on-equipment.com

The MP 100 is a compact PC-based scale suitable for a variety of applications. Touch screen technology makes the scale very easy to use.

PC-based architecture enables the ultimate in flexibility. Dynamically populate and manage menus based on best sellers. Promotions can be displayed on-screen during quiet times or triggered when specific items are weighed. Self-service mode can be used to attract customers to the scale. Training expenses are minimized as employees are able to learn the system quickly.

Avery Berkel works directly with chain store IT and Operations personnel to provide customized, fully integrated, networked applications. The MP software is versatile and can be customized to meet specific selling and management needs.

Applications

- **Home Meal Replacement (HMR)**
- **Large format label printing**
- **Deli case "credit card" price tags** (Pentax printer)
- **Customer wait-time management system** (when combined with take-a-ticket hardware)

Standard Features

- **Recipe printing**
- **Scale imaging and 'cloning'**
- **COOL labeling**

Dimensions

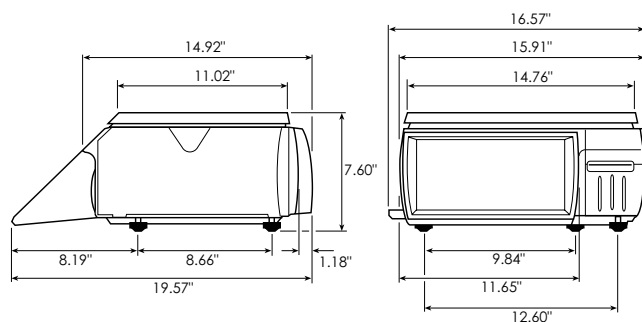

Specifications

- **Fruit & Vegetable picture library available**
- **Weighing Capacity**
30 lb x 0.01 lb
- **Processor**
800 MHz Celeron class
- **System Memory**
128 MB SDRAM expandable to 256 MB
32 MB video RAM
- **Operating System**
Windows XP Embedded
- **Program and Data Storage**
Standard 20 GB hard disk drive
- **Vendor Display**
10.4" SVGA color TFT
800 x 600 SVGA mode
- **Customer Display**
Mono LCD alpha-numeric display
Variable contrast and backlight
- **Touch screen**
Four wire resistive touch screen on vendor display
- **Interfaces**
Two x 9 way D-type RS232 ports
(5v DC power available)
USB high-speed peripheral interface bus
- **Networking**
10/100 base T Ethernet network (RJ45 socket)
- **Options**
Internal RF: 802.11b Wi-Fi compatible,
Cash drawer interface, internal
speakers, external SVGA Interface
- **Cassette Printer**
Type of printer: Direct thermal
Cassette Loading: 120 mm diameter roll
Label/Print width: 60mm/59 mm
Print speed: Up to 100 mm per second
Label formats: Soft
Paper type: Ricoh 130 or equivalent
Please refer to 'Thermal Label/Receipt
Material Specification' sheet
Diagnostics: 'Code Checker' automatically
detects and reports print head faults
Print head: Special protection coating.
Quick-change print head module
- **Agency Approvals**
Legal for Trade, NTEP Class III
USA COC# 01-010A2

Packaging - Processing

Bid on Equipment

1-847-683-7720

www.bid-on-equipment.com

Avery Berkel

**Avery Weigh-Tronix
(Retail North America)**

1758 Genesis Drive, Suite A
LaPorte, IN 46350

PH Toll-Free: 800-237-1886

PH: 219-325-9587

FAX Toll-Free: 800-237-2063

FAX: 219-325-9594

E-mail: sales@AveryBerkelUSA.com

Internet: www.AveryBerkelUSA.com



Product complies
with F.C.C.