



Aver Berkel

M601

retail system printer & scale

- ◆ Integrated design combining keyboard, operator display and printer in the same unit
- ◆ Fast print speed – enhances customer service
- ◆ Cassette printer for fast paper change and quick loading
- ◆ Full dot matrix display – easy to read, providing a superb interface with operator and customer
- ◆ Tactile keyboard with 40 programmable keys for fast product selection
- ◆ More memory power – standard data storage for around 3000 PLUs.
- ◆ Allows connection to separate weighing scale with capacity up to 6000 lb or 6000 kg

Give a commanding
performance



... with **M2** Technology

Packaging - Processing

Bid on Equipment

1-847-683-7720

www.bid-on-equipment.com

Give a commanding performance

Get more from your counter service

The new Avery Berkel **M601** printer features **M² Technology** to help you conduct your business more effectively and profitably. Specific features designed to enhance your store's performance are combined with easier to manage scale networks, proactive downtime prevention and lower ownership costs.

The **M601** model is the ideal solution for applications requiring a system label printer which requires a separate weighing platform with up to 6000 lb or 6000 kg capacity.

M601 - integrated system printer for labels & receipts

The **M601** features a versatile integrated design that prints receipts or labels. Its 40 programmable keys can be configured to your business needs to ensure fast, efficient operation.

- ◆ **Fast print speed**
With a print speed of up to 150 mm per second, the **M601** helps to reduce queues and enhance customer service.
- ◆ **Quick loading paper**
The cassette printer accommodates paper rolls up to 120 mm in size and can be removed and reloaded in seconds.
- ◆ **Display**
The full dot matrix display ensures easy operation - and the perfect medium to communicate customer messages and promotions.

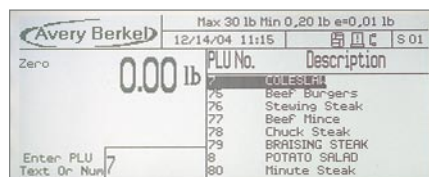

Informative dot matrix display. Example shows PLU search mode

- ◆ **Powerful memory**
The **M601** has ample data storage capability for even the largest labelling operation - with option for expansion for up to 10,000 PLUs.

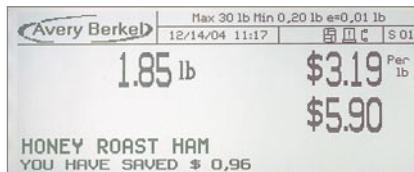

Promotional offers clearly displayed

- ◆ **Traceability**
The **M601** is ready to operate with any legislative traceability system - for any type of product - anywhere in the world.
- ◆ **Asset management**
Each printer can report on its location and status - saving the time and cost of a site inspection in times of maintenance or system upgrades.
- ◆ **E-mail alerts**
Save time and money by preventing problems before they happen - the printer can be programmed to alert store or system managers to issues such as printer running out of paper, faulty print-heads and network problems.

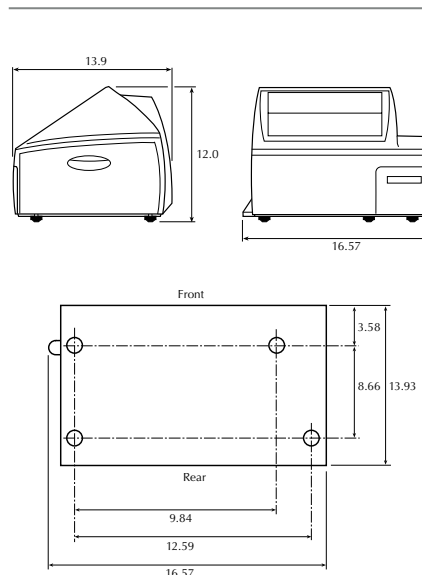

Specification

Weighing Capacities:

- 50 lb x 0.01 lb
- 30 lb x 0.01 lb
- 300 kg x 100 g
- 150 kg x 50 g
- 60 kg x 20 g
- 30 kg x 5 g
- 15 kg/6 kg x 5 g/2 g

Optional weighing interface card required for platforms comprising four load cells. When used, capacity and division size configurable up to 6000 lb or 6000 kg.

Display:

320 x 128 dot matrix display with bright white LED backlight.

Keyboard:

65 key tactile keyboard with 40 programmable keys. Optional button style rubber keyboard overlay.

Cassette Printer:

Receipt and label operation as standard. Easy loading cassette operation. 120 mm diameter roll capacity. 60 mm paper width. 150 mm/s print speed.

Print Head Diagnostics:

Patented 'Code-Checker' technology improves first-time scan rate at the checkout and warns you when the print head needs replacing.

Data Memory:

1Mb standard (around 3000 PLUs @ 24 characters text).
2Mb, 4.5Mb and 8.5Mb options (up to 10,000 PLUs).

Interfaces:

2 x internal PCMCIA interfaces.
2 x RS232 interfaces (9 way 'D' Type connectors).
1 x Cash drawer interface (RJ12 connector).
1 x Weight interface (7 pin DIN).

Inter-scale Communications:

Ethernet 10/100 Base-T (RJ-45 connector).
TCP/IP communications protocol.
Optional additional RF communications via internal PCMCIA interface.

Host Communications:

Ethernet TCP/IP interface.
Direct Modem interface (RS232).

Power:

110VAC @ 1.85 Amps

Agency Approvals:

Legal for Trade
NTEP Class III scale
USA COC# 00-057

© Avery Weigh-Tronix 2004. All rights reserved. This publication is issued to provide outline information only which, unless agreed by Avery Weigh-Tronix in writing, may not be regarded as a representation relating to the products or services concerned. Avery Weigh-Tronix reserves the right to alter without notice the specification, design, price or conditions of supply of any product or service.

Avery Weigh-Tronix
(Retail North America)
1000 Armstrong Drive, Fairmont, MN 56031

PH Toll-Free: 800-237-1886
PH: 507-238-4461
FAX Toll-Free: 800-237-2063
FAX: 507-238-8756

E-mail: sales@AveryBerkelUSA.com
Internet: www.AveryBerkelUSA.com

Packaging - Processing

Bid on Equipment

1-847-683-7720

www.bid-on-equipment.com