

Packaging - Processing  
**Bid on Equipment**  
1-847-683-7720  
[www.bid-on-equipment.com](http://www.bid-on-equipment.com)



**Avery Berkel**

# FX 210/220

uncompromising quality for the independent retailer



**Strong, lightweight & portable with mains or battery power**

# weight only & price-computing scales

The **FX 210** is a free-standing scale for general weighing applications.

The **FX 220** is a price-computing scale that is designed to offer all the functions your business needs.

## Key features & Benefits

- ▶ **Stylish, compact and tough**  
The *FX scales* are attractively designed and are tough enough to withstand everyday professional use. They offer the perfect combination of a compact footprint and a spacious weigh plate manufactured in high quality stainless steel. Additional fittings are available.
- ▶ **Instore or outdoors – You've got the power**  
The *FX range* gives you the power to use your scale in most situations, by offering a choice of mains or battery power.

Take advantage of the battery option, and the scales are instantly portable, offering up to 800 hours\* of continuous operation without the need to recharge or replace the batteries. Further battery options are also available.

\* Subject to the quality of the batteries used and product specification.

- ▶ **Choice of display**  
The *FX range* offers a wide choice of display options. The customer tower display makes highly effective use of counter space and features a very visible LCD display, to ensure that weight information remains prominent. Back lit display options are also available.

The tower display on the *FX220* displays both price and weight. A range of other functions, including seven-digit unit price, eight-digit total price, price per lb/per 100 g are also available with this model.

- ▶ **Capacity options**  
Whatever you want to weigh, from delicate items to product in bulk, the *FX scales* deliver the capacity and resolution you need. From 12 lb up to 60 lb, in a choice of resolutions to meet your requirements.

- ▶ **PLU options**  
The *FX 220* can offer 20 pin-protected PLU's as standard – including up to 10 'hot shot' keys for favorites. These may be used with a 'quick-set' feature for fast selling items.

- ▶ **Agency Approvals:**  
Legal for Trade  
NTEP Class III  
COC# 99-108  
UL Listed



*FX 210 weight only scale for general weighing applications.*



*Examples of power supply options.*

## Dimensions

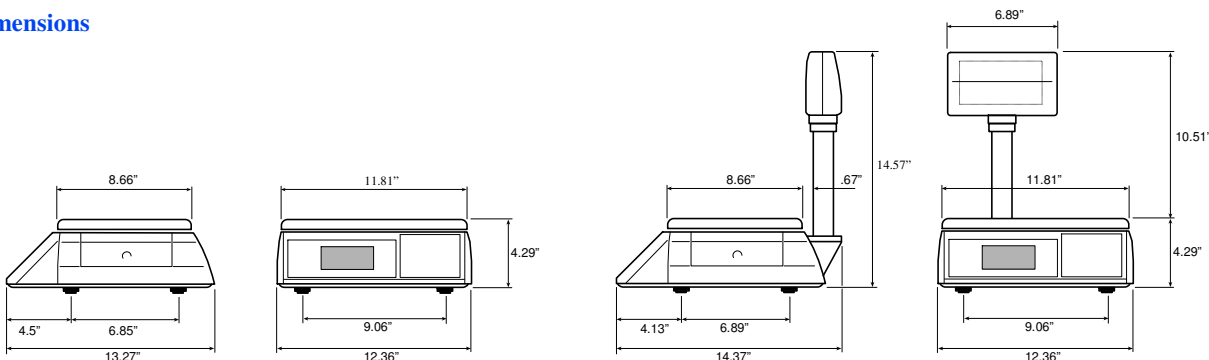

© Avery Berkel 2008. All rights reserved. This publication is issued to provide outline information only which, unless agreed by Avery Berkel, a division of ITW Limited, may not be regarded as a representation relating to the products or services concerned. Avery Berkel a division of ITW Limited alter without notice the specification, design, price or conditions of supply of any product or service.

Avery Berkel, 1000 Armstrong Dr.  
Fairmont, MN 56031, USA

Tel: 800-237-1886  
Fax: 800-237-2063  
Email: sales@averyberkelusa.com  
Website: www.averyberkelusa.com

**Packaging - Processing**  
**Bid on Equipment**  
**1-847-683-7720**  
**www.bid-on-equipment.com**