

# VERSA-PAK Rotary Tamper-Evident Filler/Sealer

*(pre-die cut lids)*

Packaging - Processing  
**Bid on Equipment**

1-847-683-7720

[www.bid-on-equipment.com](http://www.bid-on-equipment.com)



## Model RO-A1

Improved product freshness and tamper-evident food packaging—the versatile VERSA-PAK RO-A1 Rotary Filler/Sealer fills and heat seals pre-die cut foil, foil laminates, or paper laminated lids, flush or recessed seal. Optional nitrogen flush of headspace. Fills liquid, preset, semi-solid and multi-layer products in plastic, paperboard or metal containers in a large variety of shapes and sizes. Stainless steel fabrication meets or exceeds 3A, USDA and FDA standards.



**AUTOPROD Inc.**

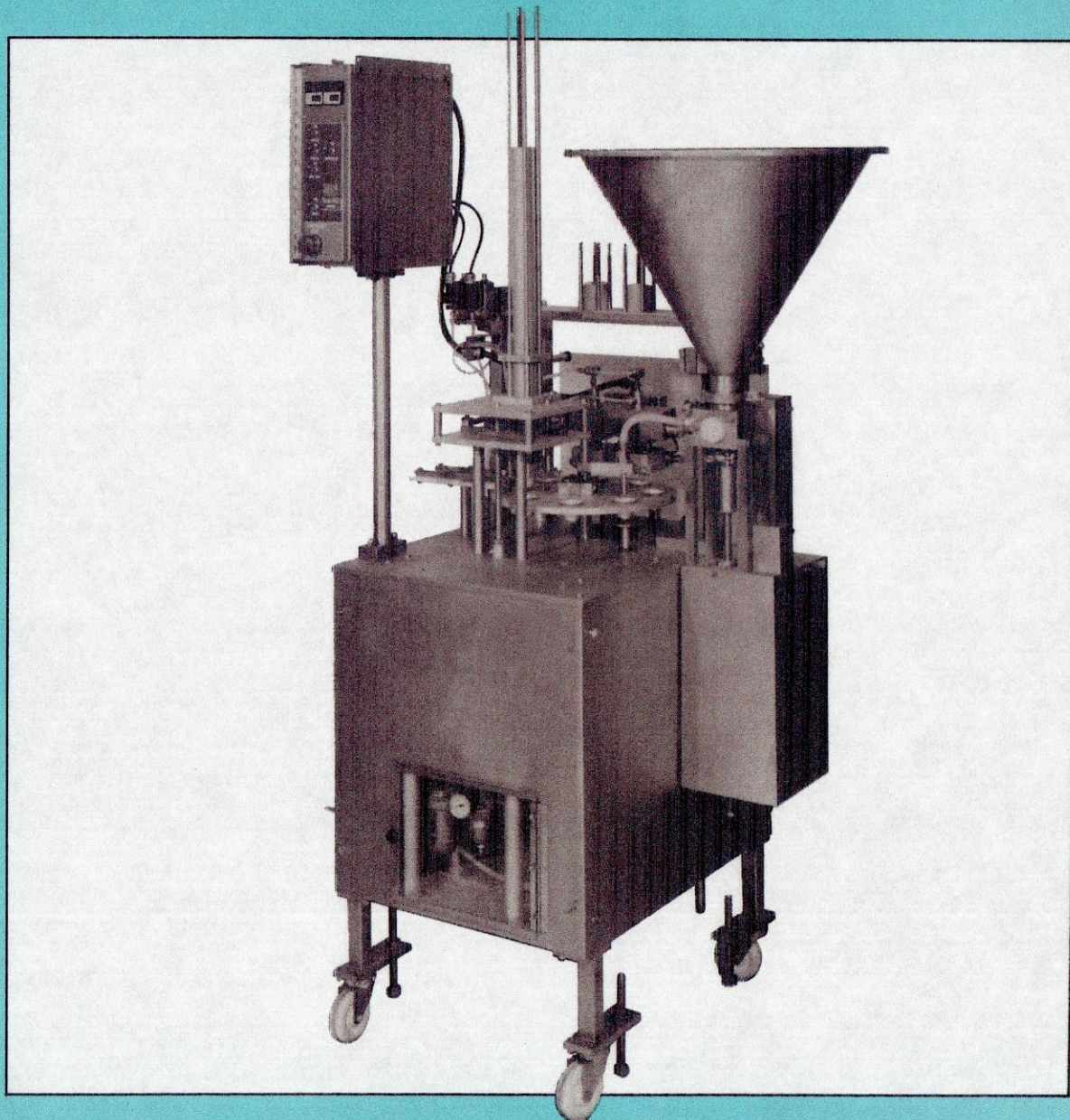

# VERSA-PAK Rotary Filler/Sealer System

*Tamper-Evident Filling for Liquid, Preset, Viscous, Semi-solid and Multiple Fill Products.*

## Model RO-A1

Autoprod's RO-A1 Rotary Filler/Sealer insures increased product freshness and tamper-evident packaging by hermetically heat sealing filled containers with pre-die cut foil, foil laminates, or paper laminated lids. An optional nitrogen flush of the headspace can extend shelf life of many products. The compact RO-A1 provides extreme filling accuracy at high speeds, and fills liquids, sauces, salads, puddings, dairy and multiple fill products in a wide variety of container shapes and sizes.

- Container Dispenser—Adjustable and versatile to accommodate from 1" to 3" diameter containers with change parts.
- Fill Sizes—Fills ½-ounce to 10-ounce containers.
- Fill Speeds—Fills up to 50 containers per minute.
- Accurate Filling—Stainless steel piston filling ensures extreme accuracy of  $\pm 1/2\%$  on most products. Additional fillers can be added to accomplish multiple fills.
- No Drip Filling—Positive cutoff nozzles fill juice, cultured dairy products, diced fruits, fruit cocktail, applesauce, potato salad, cole slaw, macaroni salad, puddings, ice cream and more.
- Tamper Evident Sealer—Pre-die cut lids are automatically placed and heat sealed in one operation.
- Coder—Bottom or top coders are available. Easy type changes and continuous printing are assured.
- Easy Cleaning—Stainless steel construction facilitates quick, thorough washdown and changeover.
- Meets or exceeds 3A, USDA, and FDA standards.

**30<sup>th</sup>**  
ANNIVERSARY  
1961-1991

*Innovators of automatic packaging machinery for over 30 years . . . and still leading the way!*

**AUTOPROD INC.**

RESIDUARY  
arwater, Florida 34620  
Fax (813) 573-0367

**Packaging - Processing**  
**Bid on Equipment**

1-847-683-7720

www.bid-on-equipment.com

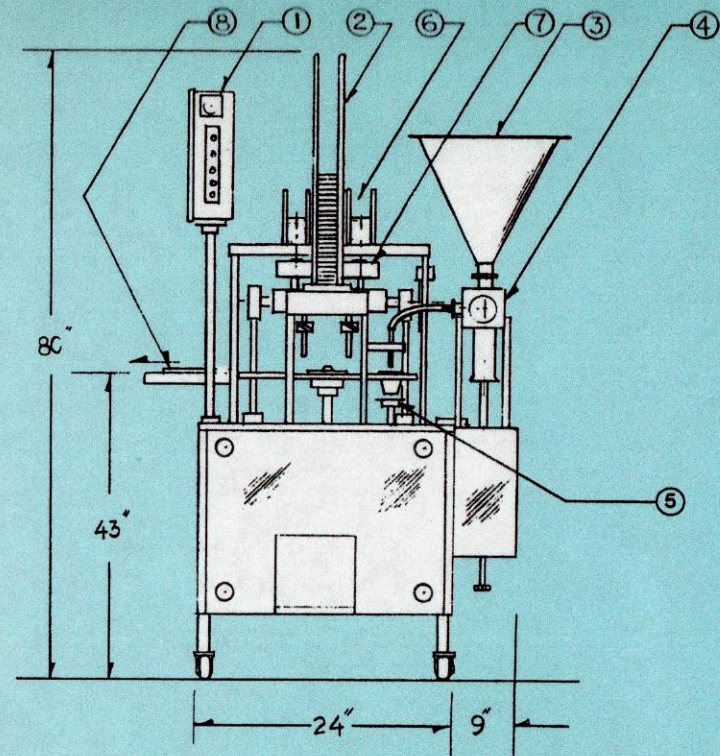

### EQUIPMENT DESCRIPTION

1. Control panel
2. Cup dispenser
3. Product hopper
4. Piston filler
5. Bottom-up fill
6. Pre-die cut lid magazine
7. Pick, place, and heat seal heads
8. Container discharge
9. Container carrier plate
10. Casters
11. Leveling screw

