

Semi-Automatic Bucket Label Applicator

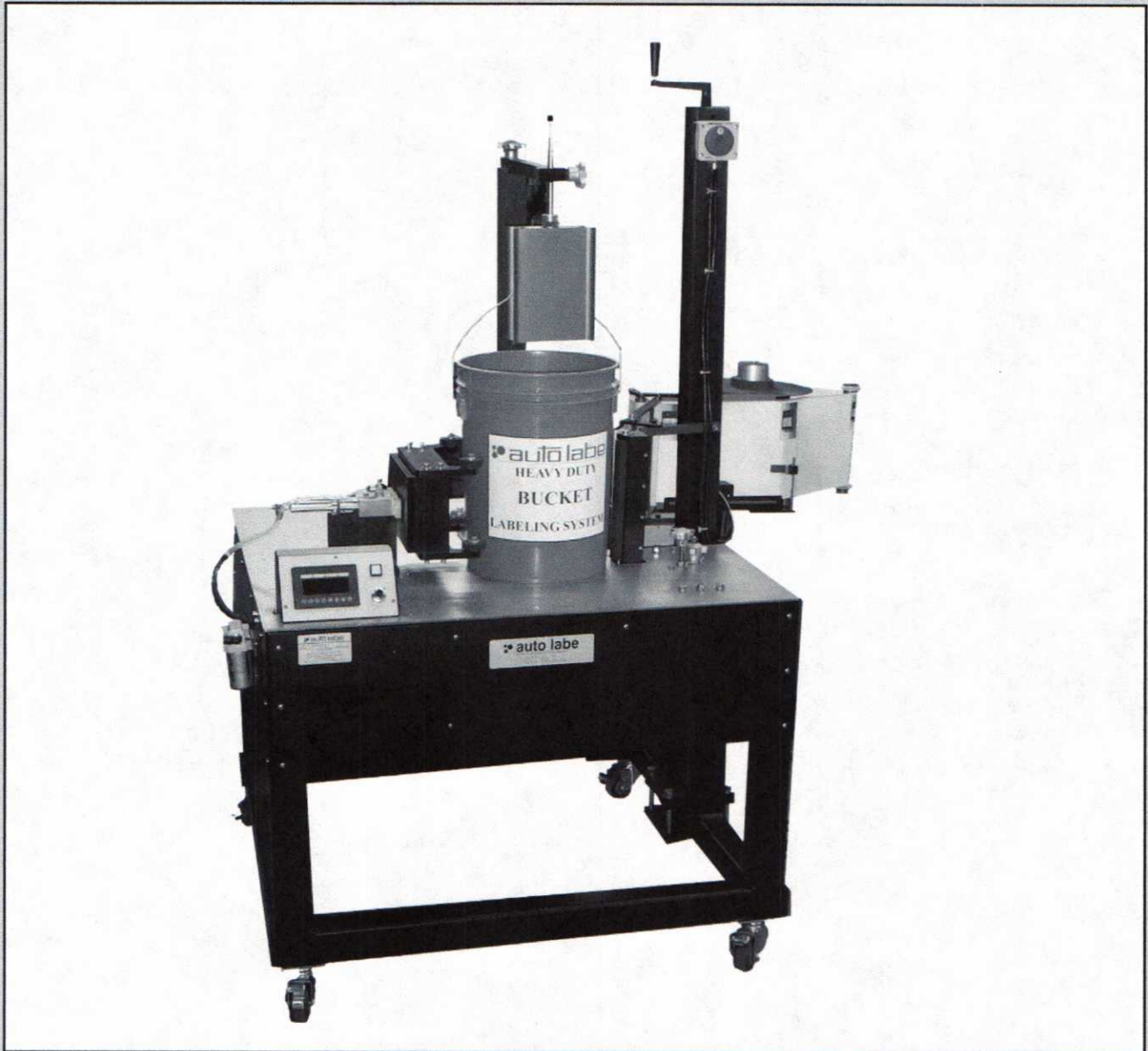

 **auto labe**

MODEL 590

Toll Free 800-634-5376

Packaging - Processing
Bid on Equipment

1-847-683-7720

www.bid-on-equipment.com

MODEL 590

Auto Labe's New Semi-Automatic Bucket Labeler is ideal for labeling empty 2.5 to 6 gallon buckets and is perfect for small production runs. This labeler can use pre-printed labels or be married with a table-top printer for Print & Apply capabilities. Built to last with only the best components for maximum versatility and performance.

Features

- Foot Pedal Activated
- Stainless Steel Top
- Heavy Duty Construction
- Caster Mounted
- Easy Operation

Specifications

- Air Requirements:**
3 CFM @ 90 PSIG
- Electric Requirements:**
110 VAC 60Hz/5 AMP
220 VAC 50 Hz (Optional)
- Equipment Weight:**
370 lbs/168 kg (approximate)

Options

- Label Orienting with PLC
- Front & Back Labeling
- LCD for PLC Control
- Print & Apply Loose Loop
- Emergency Stop Switch

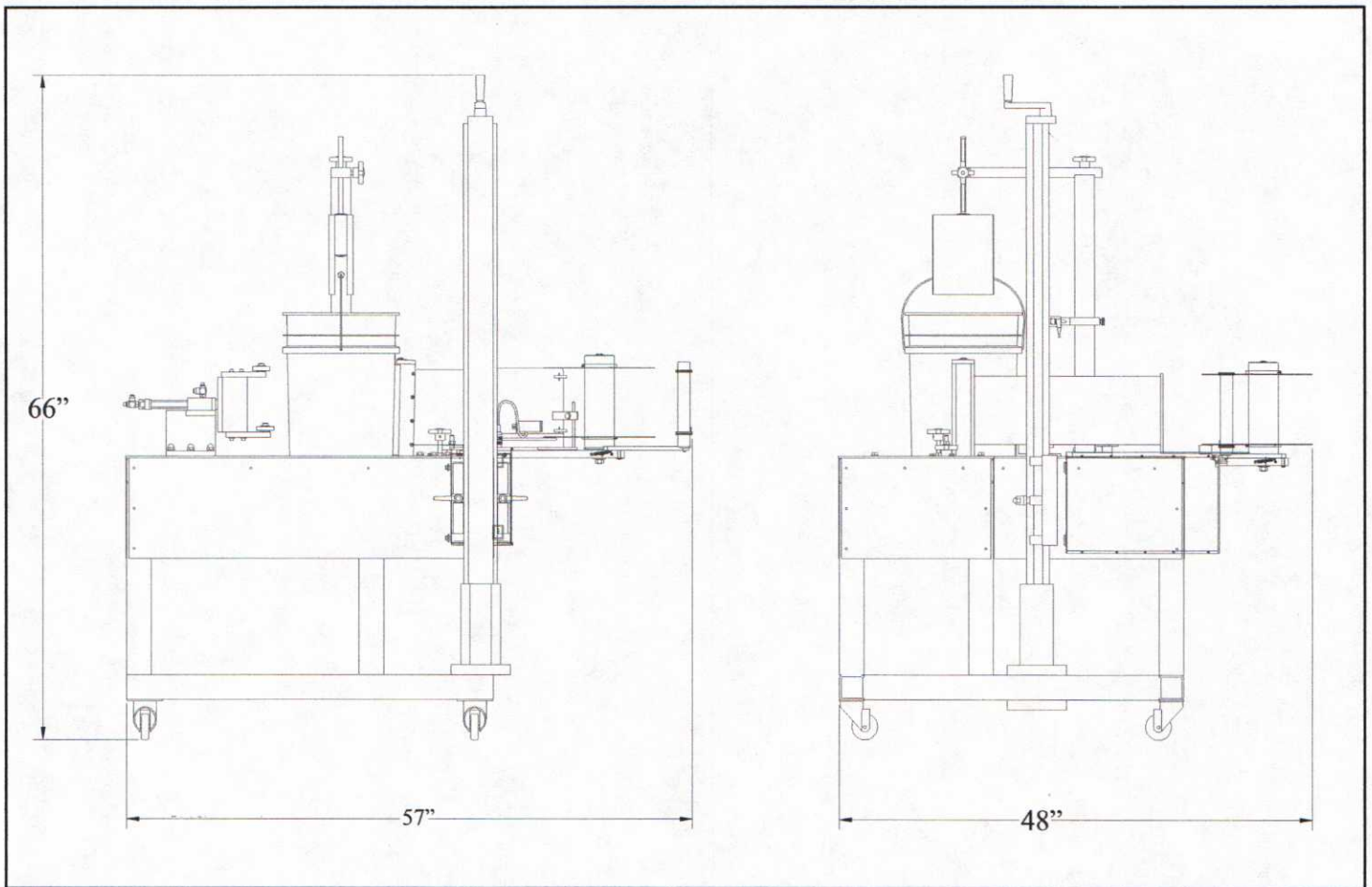

Over 35 years of commitment to quality and innovation
in the Pressure Sensitive Labeling Industry

 **auto labe**

DIVISION OF BOOTH MANUFACTURING COMPANY

3101 Industrial Avenue Two, Fort Pierce, Florida 34946

Toll Free 800-634-5376 • 772-465-4441 • FAX 772-465-5177

MEMBER



Packaging - Processing
Bid on Equipment

1-847-683-7720

www.bid-on-equipment.com