

PRODUCT INFORMATION: CENTURY® C-741

SELECTIVE CONFORMAL COATING SYSTEM AUTOMATED CONFORMAL COATING APPLICATION

The Century® C-741 Selective Conformal Coating system provides consistent, uniform dispensing of a variety of conformal coating materials for batch coating applications. The system virtually eliminates the requirement for labor-intensive board masking, providing accurately controlled patterns, film builds, and production flexibility in an automated process.

Equipped with Easy Coat® for Windows XP® (ECXP) software, uniquely designed for conformal coating applications, the system offers increased coating flexibility. Multiple coating commands can be edited simultaneously, minimizing the time required to make programming and pattern changes. Log files are configurable, allowing users to record system events and parameters for process improvement and analysis.

The C-741 system is compatible with different applicators, depending upon your production requirements. For solvent-based and 100-percent solids materials, the Film Coater module provides automated selective application of materials with viscosities of less than 100 centipoise. Complex circuit boards requiring multiple pattern widths and film builds are coated in seconds, with up to 100-percent transfer efficiency.

The Swirl Coat® SC-300 applicator handles a wide range of materials, varying in viscosity from 30 to 3500 milliPascal-second (30 to 3500 centipoise). The SC-300 is designed for use with solvent-less coatings, supporting environmentally responsible practices. Film thicknesses from 13 to 500 micrometers (0.5 to 20 mils) can be achieved.

The C-741 system incorporates downdraft ventilation for optimized vapor removal. Stainless steel surfaces provide for easy cleaning and maintenance. Several options can be added to the dispensing system to meet specific requirements, including Viscosity Control, Laser Fan Width Control.

For reliable curing as required by the material, there are two external modules: IR/convection and UV. Contact Asymtek for available configurations.



FEATURES & BENEFITS:

- Cost-effective selective application of conformal coating materials virtually eliminates extensive masking and rework, maximizing throughput.
- Easy Coat® for Windows XP® (ECXP) software, uniquely designed for conformal coating application, offers flexibility beyond generic motion control/ dispensing packages.
- Choice of applicators to fit the requirements of your production.
- Process control options for Viscosity Control and Laser Fan Width Control available.
- Factory Mutual (FM) certified

Packaging - Processing

Bid on Equipment

1-847-683-7720

www.bid-on-equipment.com

Asymtek
A NORDSON COMPANY

CENTURY C-741 BATCH SYSTEM SPECIFICATIONS:

MOTION SYSTEM:

Type: Brushless DC Stepper Motor
 X-Y Velocity: 508 mm/s (20 in./s) maximum
 381 mm/s (14 in./s) default
 Z Axis Velocity: 203 mm/s (8 in./s)
 X-Y Repeatability: ± 0.025 mm (0.001 in.), 3 sigma
 Z-Axis Repeatability: ± 0.025 mm (0.001 in.), 3 sigma
 X-Y Resolution: ± 0.025 mm (0.001 in.), 3 sigma
 Z-Axis Resolution: ± 0.025 mm (0.001 in.), 3 sigma
 Positional Accuracy: ± 0.13 mm (0.001 in.), 3 sigma

DISPENSE AREA:

C-741 Batch: 457 x 457 mm
 (18 x 18 in.)
 With Solvent-Purge Station: 457x400 mm
 (18 x 15.75 in.)
 With Laser Fan Width Control: 457x387 mm
 (18 x 15.25 in.)
Purge and solvent cups reduce available coating area.
 Configurable: PCB holder or tooling plate

COMPUTER:

Standard: Pentium® PC
 User Interface: Monitor, keyboard and mouse

SOFTWARE:

User Environment: Easy Coat® for Windows XP®
 Operating System: Windows XP®

FLUID DELIVERY METHOD:

SC-104/205 or 105/205
 Film Coater Module: Non-atomizing heat-circulating system
 Swirl Coat SC-300 Applicator: Three-mode swirl system
 PreciseCoat™ SC-400 Jet Applicator: Highly selective jet action

OTHER STANDARD FEATURES:

Purge and solvent cups
 Ventilation controls
 Door interlock controls
 Light beacon

FACILITIES REQUIREMENTS:

System Footprint: 917 x 1041 mm (36 x 41 in.)
 Air Supply: 620 kPa (90 psi, 6.2 Bar),
 up to 57 liter/min.(2 SCFM) max.
depending on configuration
 Ventilation Air: 0.28 m²/3 @ 2.5 mm water column
 (600 SCF @ 1.0 in. water column)
 Nitrogen Source: Required for moisture-sensitive
 materials– 410 kPa (60 psi, 4.1 Bar)
 @ 14 liter/min. (0.5 SCFM)
 Power (Mains): 100/120/220/240 VAC 50/60 Hz,
 10A
 Noise: ≤ 70 dBA
 System Weight: 295 kg (650 lbs.)
 Standard Compliance: SMEMA; CE
 Factory Mutual (FM) Certified

OPTIONAL FEATURES:

Bar code recognition
 system
 Flow monitoring
 Dual gun capability
 Light Curtain
 Laser pointer
 programming aid
 Low fluid sensor
 Laser Fan Width Control
 Viscosity Control System
 4-Position Tilt
 Curing options – contact
 your sales representative

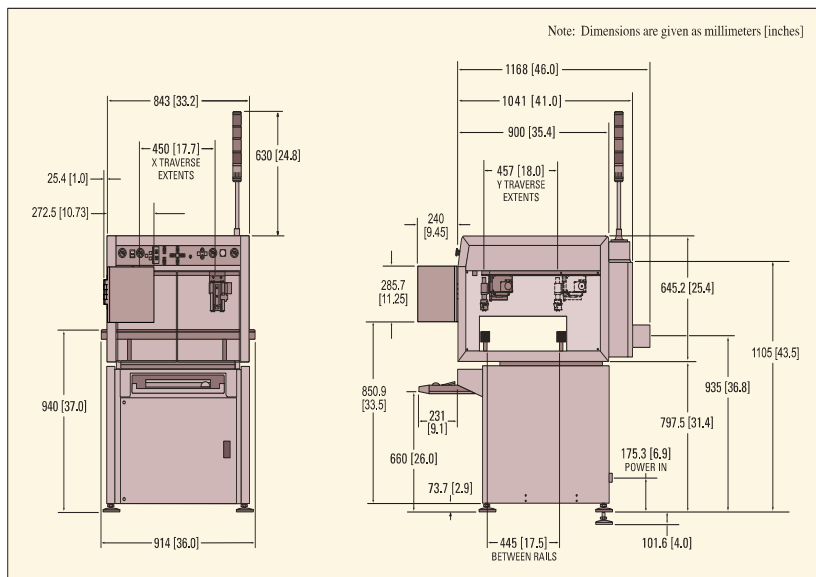

Century®, Asymtek® Swirl Coat®, and Easy Coat® are registered trademarks of Nordson Corporation. Windows® and Windows NT® are registered trademarks of Microsoft, Inc. Pentium® is a registered trademark of Intel Corporation.

All specifications are believed to be a true and accurate representation of system capabilities and are subject to change without notice. Contact Asymtek for your specific application requirements.

Intel Corporation's 2003 -2007 SCQI Award Winner

©2008 Asymtek Published 3/08 Asymtek is ISO 9001:2000 Certified

ASYMTEK HEADQUARTERS
 2762 Loker Avenue West
 Carlsbad, CA 92010-6603 USA
 U.S.: 1-800-ASYMTEK
 Tel: +1-760-431-1919
 Fax: +1-760-431-2678

INTERNATIONAL SUPPORT
 Europe: +31 (0) 43-352-4466
 Beijing: +86- 10 8453 6388
 Guangzhou: +86-20 8554 9996
 Shanghai: +86-21-3866-9166
 Japan: +81 (0) 3-5762-2801
 Korea: + 82-31-765-8337
 S.E. Asia +65 6796 9514
 Taiwan: +886-2-2902-1860

Email: info@asymtek.com

Website: www.asymtek.com

Asymtek
 A NORDSON COMPANY