

PROCESS PLATFORM: CENTURY® C-740

SELECTIVE CONFORMAL COATING SYSTEM AUTOMATED CONFORMAL COATING APPLICATION

The Century® C-740 Series Selective Conformal Coating system provides consistent, uniform dispensing of a variety of conformal coating materials for inline coating applications. The system virtually eliminates the requirement for labor-intensive board masking, providing accurately controlled patterns, film builds, and production flexibility in an automated process.

Equipped with Easy Coat® for Windows NT® (ECNT) software, uniquely designed for conformal coating applications, the system offers increased coating flexibility. Multiple coating commands can be edited simultaneously, minimizing the time required to make programming and pattern changes. Log files are configurable, allowing users to record system events and parameters for process improvement and analysis.

The tri-mode Swirl Coat® module is ideal for coating a high mix of circuit boards using a wide range of 100-percent solids materials with viscosities from 30 to 3,500 centipoise. By varying the volume, dispensing pressure, and the use of shaping air jets, conformal coating materials can be dispensed in a bead, monofilament, or swirl pattern. The system's ECNT software allows coating modes to be changed on-the-fly in a single coating cycle, without interrupting the coating sequence.

For application of solvent-based and 100-percent solids materials, the Film Coater module provides automated, selective application of materials with viscosities of less than 100 centipoise. Complex circuit boards requiring multiple pattern widths and film builds are coated in seconds, with up to 100-percent transfer efficiency.

The C-740 system incorporates downdraft ventilation for optimized vapor removal. Stainless steel surfaces provide for easy cleaning and maintenance. Several options can be added to the dispensing system to meet specific application requirements, including a belt conveyor with lift/clamps mechanism and a light curtain. An inline board inverter is an external option for two-sided conformal coating. For reliable curing as required by the material, there are two external modules: IR/convection and UV. Contact Asymtek for available configurations.



FEATURES:

- Cost-effective selective application of conformal coating materials virtually eliminates extensive masking and rework, maximizing throughput
- Easy Coat for Windows NT software, uniquely designed for conformal coating application, offers flexibility beyond generic motion control/dispensing packages
- The tri-mode Swirl Coat module delivers from 0.25 to over 20 mils of 100-percent solids materials in a single pass
- The Film Coater module provides precise, non-atomizing coating of complex circuit boards with up to 100-percent transfer efficiency
- Factory Mutual (FM) certified

Packaging - Processing

Bid on Equipment

1-847-683-7720

www.bid-on-equipment.com

Asymtek®
A NORDSON COMPANY

CENTURY C-740 SYSTEM SPECIFICATIONS

MOTION SYSTEM:

Type:	Brushless DC Stepper Motor
X-Y Velocity:	508 mm/s (20 in./s) maximum 381 mm/s (15 in./s) default
Z Axis Velocity:	203 mm/s (8 in./s)
X-Y Repeatability:	±0.025 mm (0.001 in.), 3 sigma
Z-Axis Repeatability:	±0.025 mm (0.001 in.), 3 sigma
X-Y Resolution:	±0.025 mm (0.001 in.), 3 sigma
Z-Axis Resolution:	±0.025 mm (0.001 in.), 3 sigma
Positional Accuracy:	±0.13 mm (0.005 in.), 3 sigma

DISPENSE AREA:

Inline:	457 x 432 mm (18 x 17 in.)
With Solvent-purge station:	457 x 400 mm (18 x 15.75 in.)
With Fan Width Control:	457 x 387 mm (18 x 15.25 in.) <i>Note: board size up to 400 mm (15.5 in.) wide can be accommodated.</i>

CONVEYOR:

Inline:	Standard chain conveyor with queue stop and pinning set Manual width adjustment from 51 to 457 mm (2 to 18 in.)
Maximum Clearance:	89 mm (3.5 in.) above and below PCB
Maximum Pallet/PCB Weight:	2 kg (5.5 lbs.)

COMPUTER:

Computer:	Pentium® PC
User Interface:	Monitor, keyboard and mouse

SOFTWARE:

User Environment:	Easy Coat® for Windows NT®
Operating System:	Windows NT®

FLUID DELIVERY METHOD:

SC-104/105	Film Coater module: Non-atomizing, heat-circulating system
SC-204/205	Film Coater module: Non-atomizing, non-circulating system
Swirl Coat™ module:	Tri-mode swirl system

OTHER STANDARD FEATURES:

Purge and solvent cups
Ventilation controls
Door interlock controls
Light beacon

FACILITIES REQUIREMENTS:

System Footprint:	917 x 1041 mm (36 x 41 in.)
Air Supply:	620 kPa (90 psi, 6.2 Bar), up to 57 liter/min. (2 SCFM) max. depending on configuration
Ventilation Air:	0.28 m³/s @ 25 mm water column (600 SCFM @ 1.0 in. water column)
Nitrogen Source:	Required for moisture-sensitive materials – 410 kPa (60 psi, 4.1 Bar) @ 14 liter/min. (0.5 CFM)
Power (Mains):	100/120/220/240 VAC 50/60 Hz, 10 A
Noise:	<70 dBA
System Weight:	295 kg (650 lbs.)
Standard Compliance:	SMEMA; CE

OPTIONAL FEATURES:

Belt conveyor with lift/clamps
IR/convection curing module
Fan Width Control system for
SC-105/205 Film Coater modules
Bar code recognition system
Inline board inverter module
Dual gun capability
Light Curtain
Laser pointer programming aid
Low fluid sensor

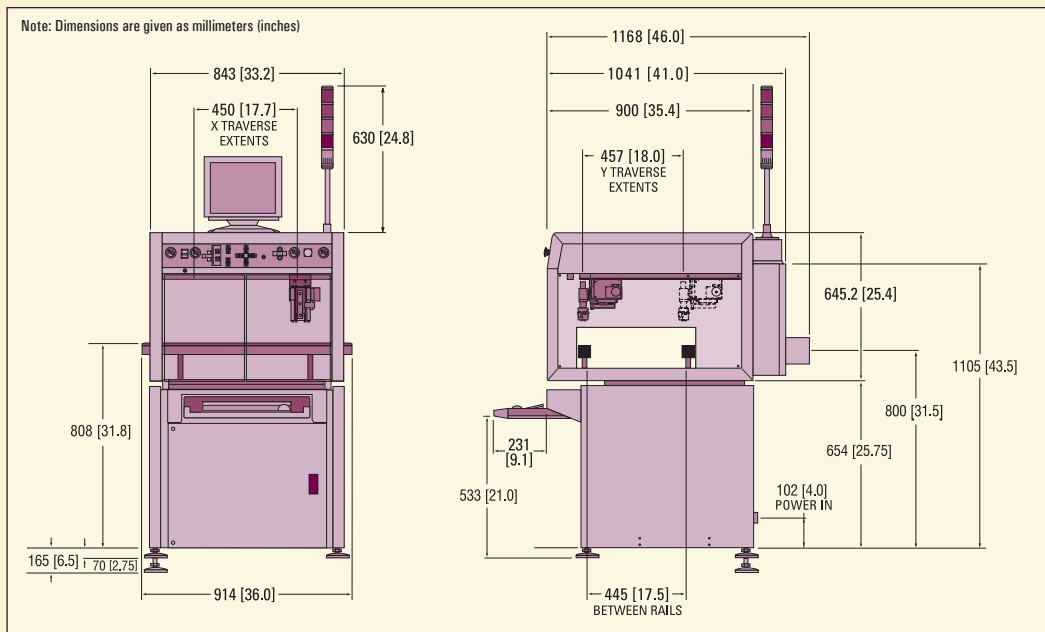

Packaging - Processing
Bid on Equipment
1-847-683-7720
www.bid-on-equipment.com

Please contact these locations for the name of your local representative:

HEADQUARTERS

2762 Loker Avenue West
Carlsbad, CA 92008-6603 USA
U.S. Toll Free: 1-800-ASYMTEK
Tel: (760) 431-1919
Fax: (760) 431-2678

INTERNATIONAL SALES

Europe: +31 (0) 43-352-4466
Japan: +81 (0) 3-5762-2801
Korea: + 82-31-766-8321
S.E. Asia +65 (0) 6896-9630
Taiwan: +886-2-2902-1860

Century® and Asymtek® and are registered trademarks of Asymtek. Swirl Coat®, Easy Coat® and Nordson® are trademarks of Nordson Corporation. Windows® and Windows NT® are registered trademarks of Microsoft, Inc. Pentium® is a registered trademark of Intel Corporation.

All specifications are believed to be a true and accurate representation of system capabilities and are subject to change without notice. Contact Asymtek for your specific application requirements.

©2005 Asymtek Published 8/05 Asymtek is ISO 9001 Certified

ASL-00-2102 Rev B

www.asymtek.com

Asymtek
A NORDSON COMPANY