

Packaging - Processing  
**Bid on Equipment**

1-847-683-7720

www.bid-on-equipment.com

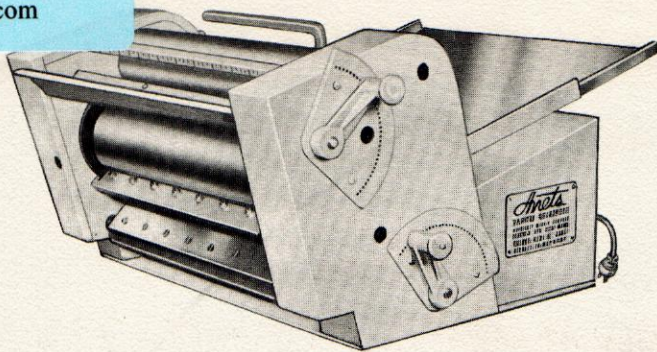

*Anets*

**MDR-6C**  
**MDR-6S**

*versatile*

# DOUGH SHEETER

*for pie, pizza, sweet goods*



This versatile, portable Anets Dough Sheeter provides fast, uniform production of doughs for pies, pizza, and sweet goods. Two passes can be made with a single adjustment. Unit is adjustable for various thicknesses . . . metered for repeat settings. Dough Sheeter can be used as cross-grainer without distortion of the dough. The smooth, sure operation of this unit eliminates excessive flour dusting. Dough Sheeter has three large, precision-ground rollers that actually do the work of four. Unit may be moved easily to any section or area to match production needs, step-up volume.

Available as independent Dough-Sheeter . . . MDR-6C. Available with welded 14-gauge steel cabinet, with four casters . . . MDR-6S.

*faster operation. . .*

*less adjustments*

# Anets two-pass DOUGH SHEETER

## MDR-6C MDR-6S

**Dough Sheeter:**  $\frac{3}{16}$ " steel plate frame.

**Cabinet:** Welded 14-gauge steel, baked white enamel finish. 3" casters.

**Dough Rollers:** Three rollers, 20" long by  $4\frac{3}{8}$ " in diameter. Precision ground for uniform sheeting. Adjustable from 0" to 1".

**Scrapers:** Spring-loaded, removable scrapers for easy cleaning, compliance with sanitary standards. Perfectly aligned to swing with rollers in all operating positions.

**Flour Tray:** Conveniently located on swivel base on top frame.

**Roller Speed:** 49 feet per minute.

**Motor:**  $\frac{1}{4}$  H.P., 110 volts AC, 60 cycle, single phase. Bar type Safety Switch is located above the dough guides for easy start-up and shut-off of unit. Chain drive speed reducer and motor fully enclosed. 6-foot cord.

**Shipping Weight (approx.):**

MDR-6C . . . . . 325 lbs. MDR-6S . . . . . 465 lbs.

## CONSTRUCTION FEATURES AND SPECIFICATIONS

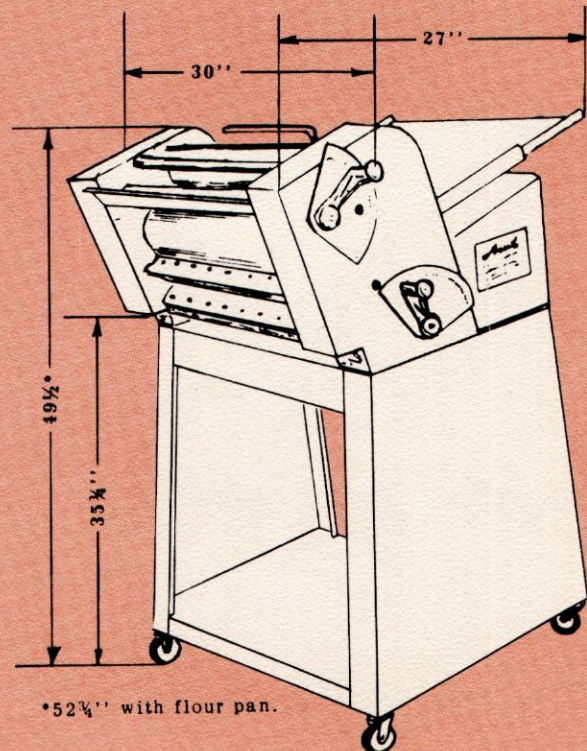
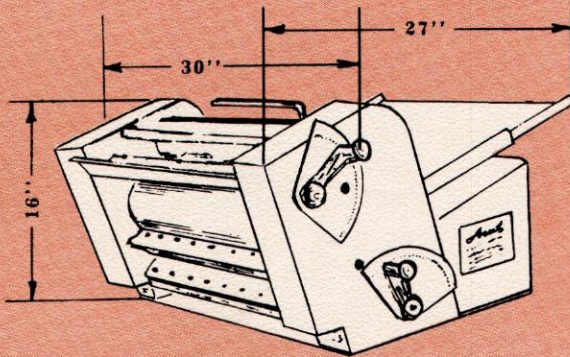

Owing to our policy of continuous product improvement, specifications are subject to change without notice.

**ANETSBERGER BROTHERS, INC.**

180 North Anets Drive • Northbrook, Illinois

**Packaging - Processing  
Bid on Equipment**

1-847-683-7720

www.bid-on-equipment.com