

Packaging - Processing
Bid on Equipment

1-847-683-7720

www.bid-on-equipment.com

Anets

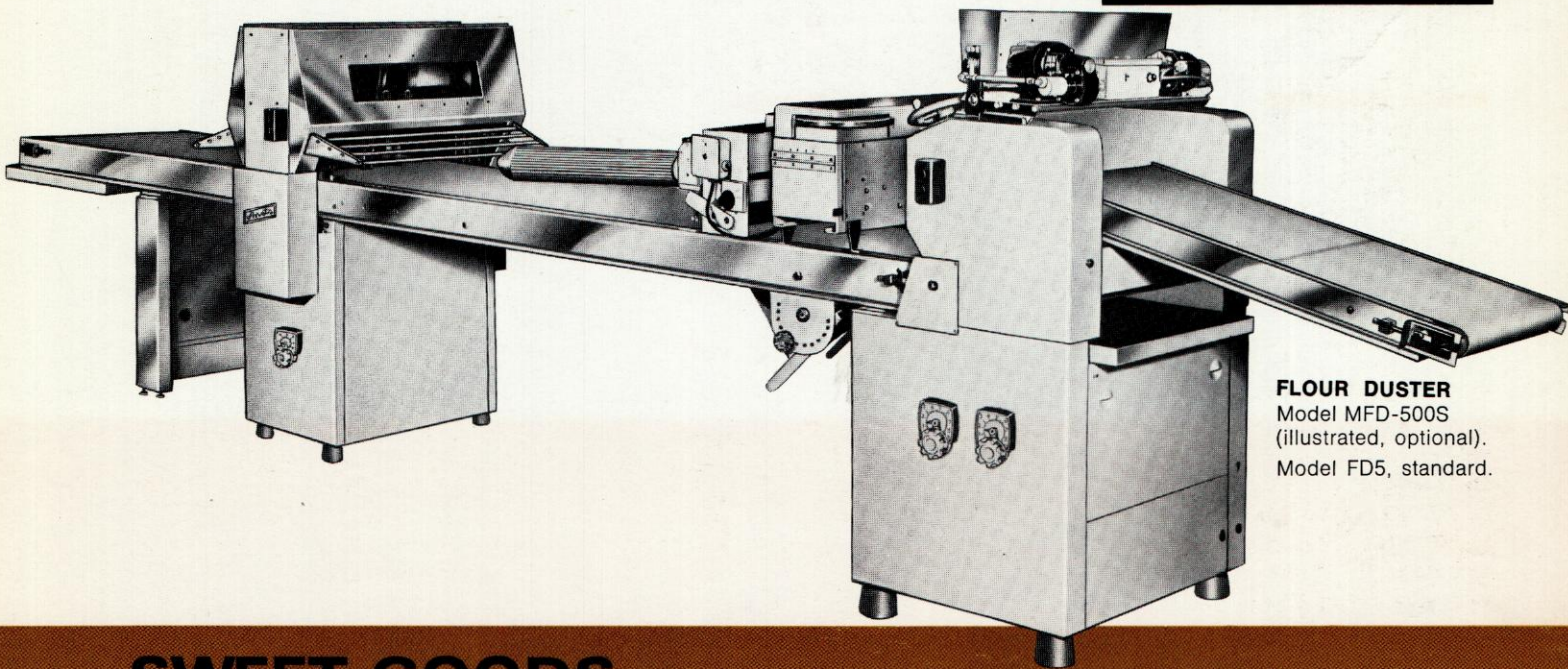

FLOUR DUSTER
Model MFD-500S
(illustrated, optional).
Model FD5, standard.

**SWEET GOODS
PRODUCTION TABLE**

ST-7

Automate your sweet goods production with the Anets Table and Accessories . . . maintain the highest quality and uniformity. Here are the extra "skilled hands" for variety, volume, peak production periods . . . automatically, economically . . . with no labor shortages, no personnel problems. Meet all your production requirements with a wide range of speeds . . . for roll-in work, sheeting, filling, forming, cutting sweet doughs, danish, puff-paste and pie dough. Fully flexible . . . production table will also sheet and cut fried goods.

ANETS AUTOMATED ACCESSORIES

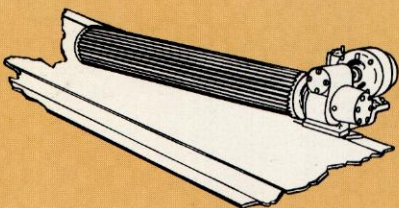

ROLL WINDER

For coiling cinnamon rolls, butter-fly rolls, honeybuns, etc. Available for right or left hand operation—or both.

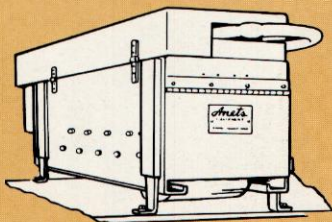

CROSS ROLLER

Designed for continuous high speed production . . . assures exact thickness, uniform dough structure and fine finishing.

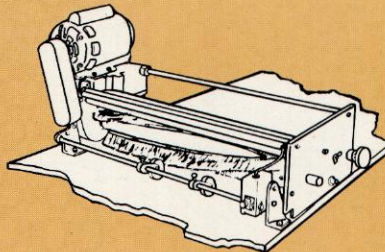

FLOUR BRUSH

Flour is aerated and excess is removed and deposited in container for re-use. Adjustable to dough thickness. Automatic start/stop switch.

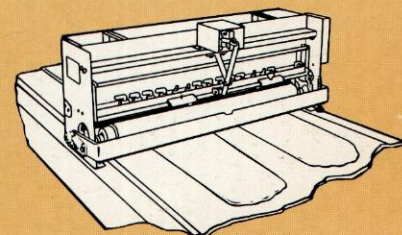

DOUGH OILER

Accurate application, eliminates messy and laborious hand-brushing methods. Thermostatically controlled tank keeps oil and liquids flowing freely.

performance proved around the world!

Anets

PRODUCTION TABLE ST-7

Custom Production—You can customize your Anets Production Table to your needs no matter how small or large... add more Anets Automated Accessories for new variety and a more profitable volume. You can cut your costs without impairing quality and finished appearance. You will have more precise control over dough-piece sizes, fillings, costly ingredients... resulting in greater yield.

Automated Accessories—Anets Automated Accessories are engineered to stand the stress of stepped-up production schedules and to turn out better quality products. Anets Accessories have advanced design that automatically eliminates virtually all hand operations, saves up to 50% in labor costs.

ACT—Anets Consulting Team of top-flight engineers will provide recommendations for savings in labor and improved profitability. Both your present needs and provisions for future expansion are considered. Anets provides this professional service at no charge or obligation. ACT now!

Specifications subject to change without notice.

FEATURES AND SPECIFICATIONS

General design and components in conformance with BISSC requirements.

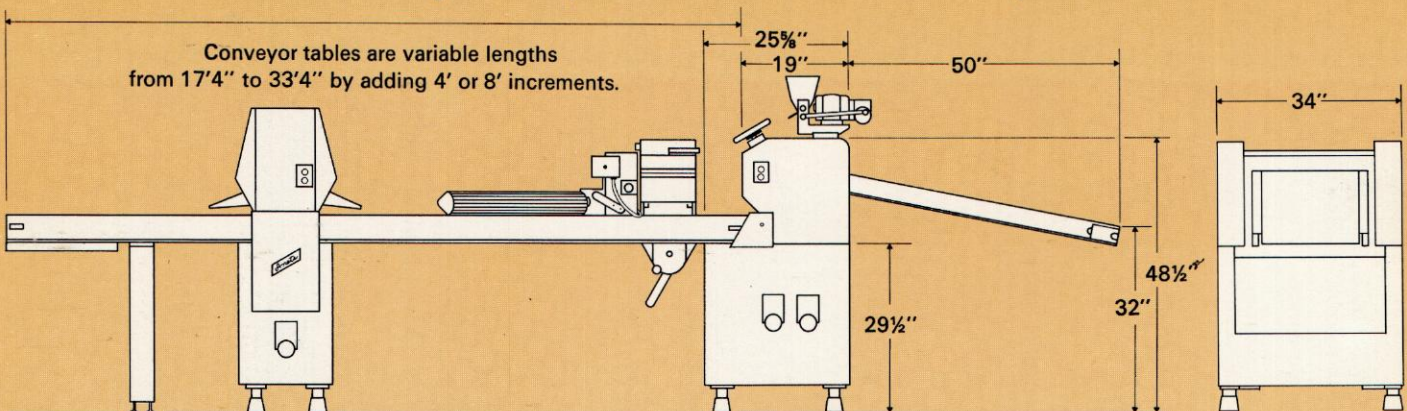

CONSTRUCTION

Precision machined parts and heavy formed sanitary constructed frame. Finished in non-toxic white enamel. (Stainless steel optional).

SHEETING ROLLERS

Two 6 1/2" (dia.) x 20" (wide) stainless steel rollers. Corrosion proof flanges. Roller adjustment 0" to 1". Optional 14" (dia.) x 24" (wide) stainless steel rollers.

SCRAPERS

Perfectly aligned and swing with rollers through entire adjustment range.

BELT TAKE-UP

Maintains tension during operation; tension released after operation to facilitate cleaning of belt.

CONVEYOR BEDS

Formed stainless steel.

STANDARD DRIVES

A 3/4 H.P. varidrive drives both rollers and infeed table belt. A 3/4 H.P. varidrive drives the production conveyor belt. Optional: 1/4 H.P. varidrive to drive the infeed conveyor belt making

it independently variable from the rollers. With all three variable drives, infeed conveyor belt, rollers, and production conveyor belt are independently variable driven for best synchronization and relaxation of dough. Speed range of production conveyor belt is 3' to 30' per minute for sweet goods production.

CONVEYOR PASS THRU SHEETER BASE

Optional base with raised sides allowing production conveyor to pass under sheeter allowing flour to be put on the belt before dough is laid on production conveyor. Prevents dough from sticking to belt.

DIE CUT UNIT

Precision machined with bronze cutter slides. Stainless steel covers and aluminum guards. Cutter and back-up plate travel with belt while cutting. Unit is driven by 3/4 H.P. varidrive. Cuts 26 to 260 strokes per minute.

ROLL SIZER

Holds wound-up dough strip up to 4" diameter while being cut. Operates with die cut blade.

STAINLESS STEEL PANNING AREAS optional.

PRODUCTION TABLE CONVEYOR BELT

24" wide conveyor belt neoprene impregnated for sanitation. Vulcanized endless.

INFEED BELT

18" wide infeed belt. Sheeter unit with 14" dia. rollers has 22" wide infeed belt. Belts are neoprene impregnated for sanitation.

STANDARD VOLTAGE OF VARIDRIVES

230/460 V., 3 ph., 60hz. Special voltages available.

ACCESSORY SPACE AND ELECTRICAL REQUIREMENTS

Single Cross Rollers, 22"; Flour Brush, 20"; Dough Oiler, 11"; Cinnamon Duster, 13"; Paste Spreader, 23"; and Single Roll Winder, 48". 115/230 V, 1 ph., 60hz. Special voltages available.

PRICES AND SHIPPING WEIGHTS
Upon request.