

DOUGH OILER

DO-3

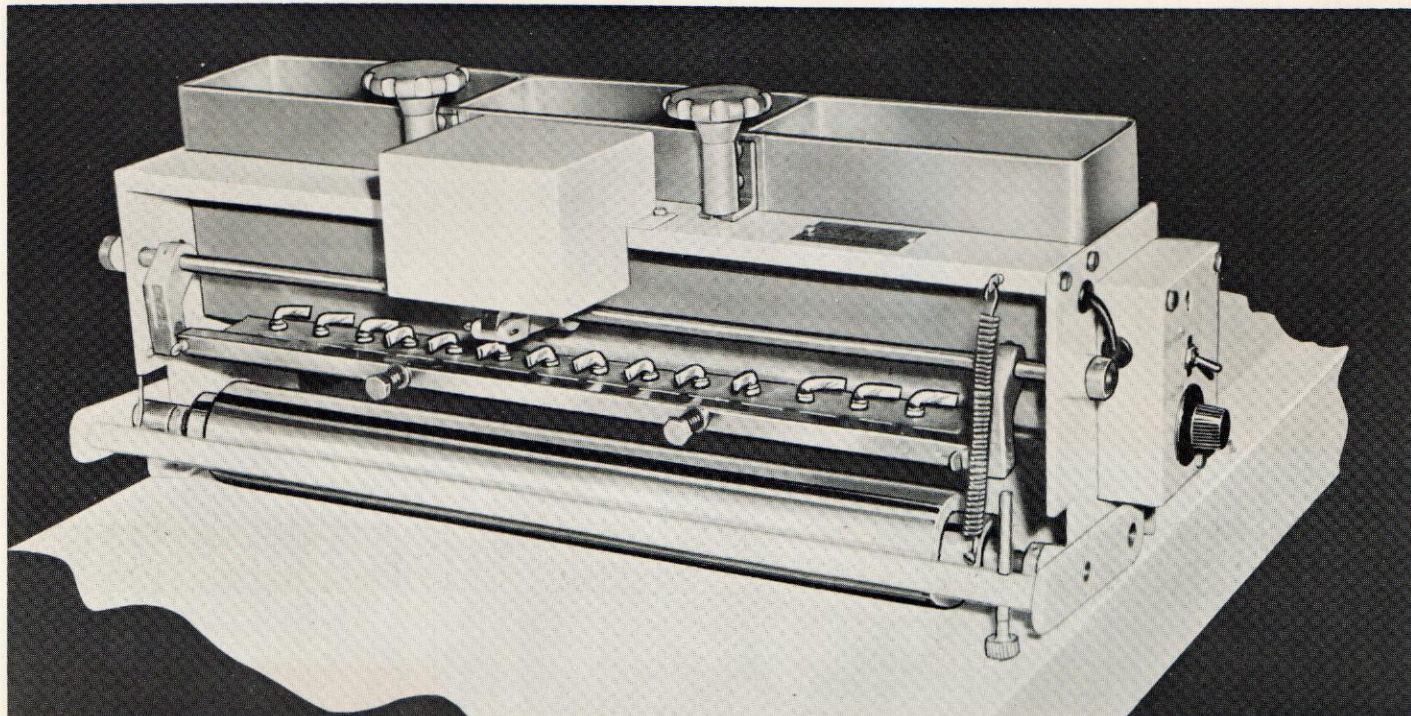

Anets accessories

Anets Accessories are engineered to stand the stress of stepped-up production schedules and to turn out more uniform quality products. Anets Accessories have advanced design that automatically eliminates virtually all hand operations, saves up to 50% in labor costs. Many also available as portable units.

Individually adjustable valves control the area of oil application to the dough piece.

Powerful solenoid operates gate which controls flow of oil to roller.

Dough-driven machined aluminum roller quickly adjustable to type and thickness of dough strip.

One-piece aluminum hopper removable for easy cleaning.

Thermostatically controlled electric heating elements keep oil at proper viscosity for uniform application.

Anets

**AUTOMATICALLY
OILS
SELECTED AREA
OF DOUGH STRIP**

SPECIFICATIONS

FRAME CONSTRUCTION: Welded Steel, white enamel finish.

ROLLER: Machined aluminum; suspended in movable yoke with convenient height adjusting screw. Roller easily removed for cleaning.

OIL TANK: One-piece cast aluminum construction. Complete tank readily removable for easy cleaning. Valve manifold with 14 valves integral part of tank.

FLOW GATE: Solenoid operated gate controls flow of oil and water to roller for application of dough piece.

ELECTRICAL SPECIFICATIONS: 115 Volts, 60 Hz. 1 Phase.

APPROXIMATE SHIPPING WEIGHT: 90 Lbs.

Table space required: 11".

Anetsberger Brothers, Inc., whose policy is one of continuous improvement, reserves the right to discontinue or change specifications, models or prices at any time without incurring obligation.

PERFORMANCE PROVED — BACKED BY MORE THAN 40 YEARS EXPERIENCE

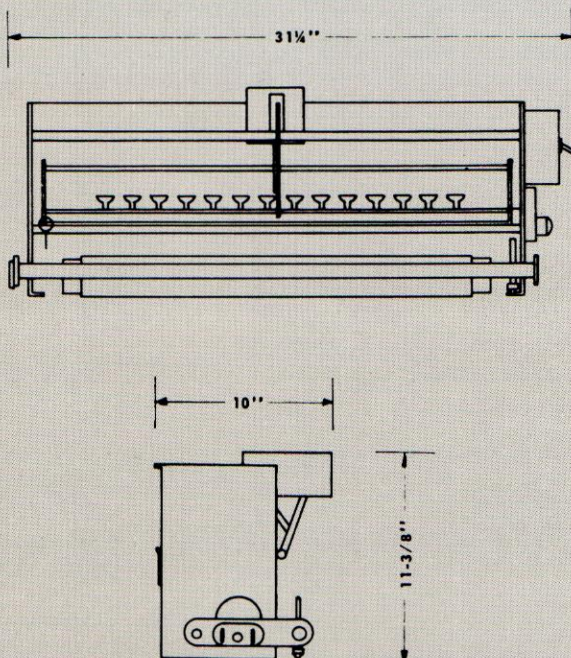

*Manufactured
Exclusively
by*

**ANETSBERGER
BROTHERS, INC.**

180 Anets Drive
Northbrook, Illinois
60062

**Packaging - Processing
Bid on Equipment**

1-847-683-7720
www.bid-on-equipment.com