

CINNAMON DEPOSITOR

CD-2

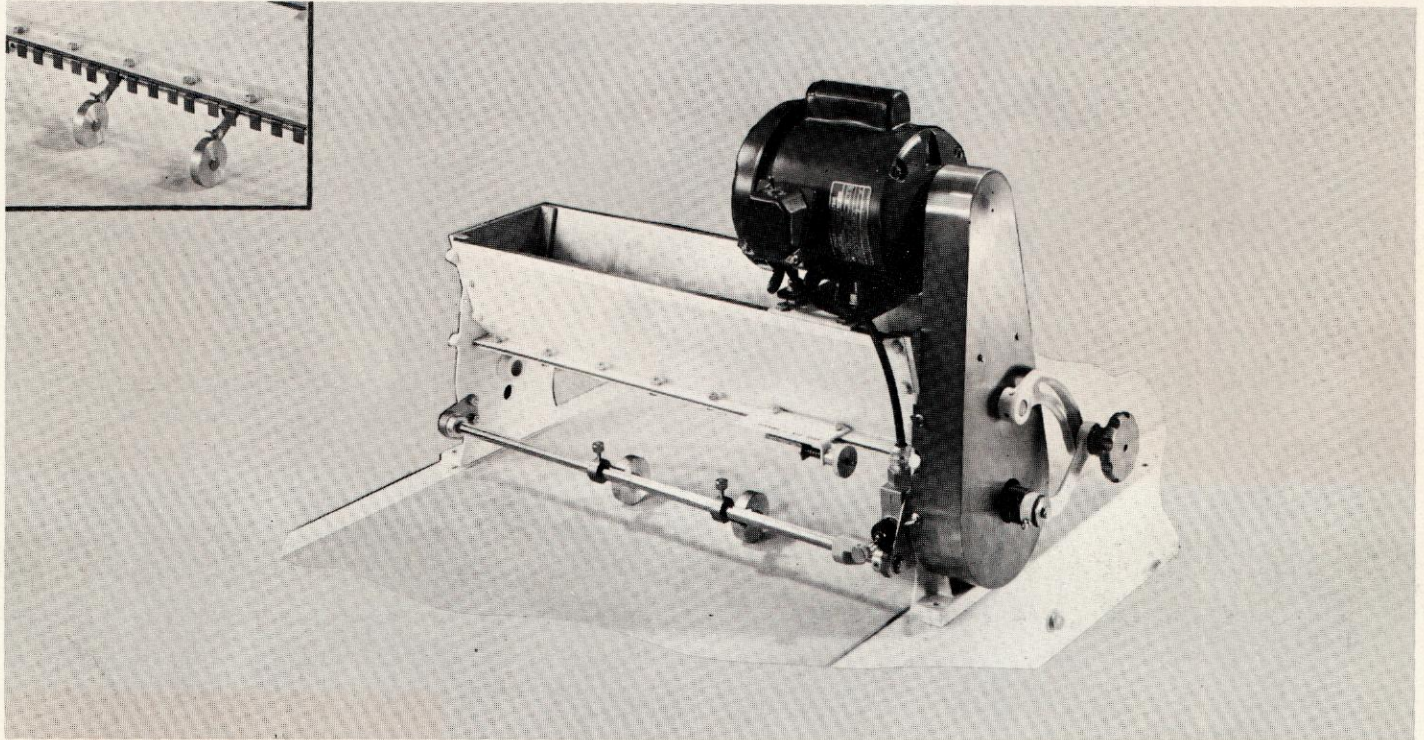

Anets accessories

Anets Accessories are engineered to stand the stress of stepped-up production schedules and to turn out more uniform quality products. Anets Accessories have advanced design that automatically eliminates virtually all hand operations, saves up to 50% in labor costs. Many also available as portable units.

Deposits desired amount of dry cinnamon in 19 selected areas across the belt.

Conserves material and improves product quality through uniform depositing.

Automatically starts when dough piece passes beneath depositor and shuts off at end of dough piece—no cinnamon is deposited on belt.

Easy to set flow adjuster has visual hole size indicator.

Adjustable rocker arm agitates the cinnamon to produce a uniform flow.

Anets

Adjustable contact rollers actuate micro-switch to automatically start depositor when dough strips are beneath unit. Automatically shuts off at end of dough piece.

No cinnamon deposited on belt.

SPECIFICATIONS

CONSTRUCTION: Sheet aluminum hopper with cast aluminum end frames. Fully enclosed V-belt drive. White enamel finish. All oil ports spring-ball sealed to keep out dust and flour.

SELECTOR TABS: Finger tip selector tabs pull out at 1" intervals to control cinnamon flow through sifter plate holes. Nineteen selector tabs permit full 23" wide flow across belt.

MOTOR: 1/6 H.P. totally enclosed. Equipped with main switch, cord and plug.

ELECTRICAL: 115 Volt, 60 Cycles, Single Phase.

SHIPPING WEIGHT: Approximately 113 pounds. Requires 13" of table space.

Anetsberger Brothers, Inc., whose policy is one of continuous improvement, reserves the right to discontinue or change specifications, models or prices at any time without incurring obligation.

PERFORMANCE PROVED — BACKED BY MORE THAN 40 YEARS EXPERIENCE

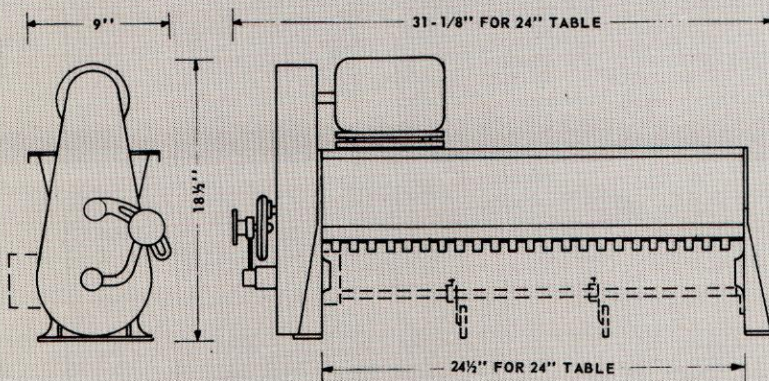

*Manufactured
Exclusively
by*

**ANETSBERGER
BROTHERS, INC.**

180 Anets Drive
Northbrook, Illinois
60062

312 - 272-0770

**Packaging - Processing
Bid on Equipment**

1-847-683-7720

www.bid-on-equipment.com