

AMF

MULTIVAC FLOUR RECLAIM AND RECYCLING SYSTEM



- **Designed to Reclaim Dusting Flour from Multiple Pick-up Points and Recycle it Through the System. This System will also Receive Flour from the Plant Flour Feed System.**
- **Designed for Use with AMF Accupan Bun Systems**
- **Collection Hoods and Hoppers are Custom Designed to Meet Specific Layout Requirements**

FEATURES & BENEFITS

Fully Automatic Flour Collection

- **Designed to operate with AMF controls, no additional programming required**
- **Constantly reclaims flour from zig-zag, panner, moulder and tray tripper**

Advanced Filter Cleaning

- **Time adjustable compressed air blast filter cleaning**
- **Polygonal shape filters clean more thoroughly than bag filters**
- **Polygonal pocket filters require less stress for cleaning resulting in longer filter life**

- **Filter cleaning is continuous and does not require system shutdown**

Corrosion Resistant Stainless Steel Design

- **Stainless steel filter body**
- **Stainless steel collector hoppers**
- **Stainless steel collector hoods**
- **Stainless steel collector tubing**

MULTIVAC FLOUR RECLAIM AND RECYCLING SYSTEM

MECHANICAL FEATURES

- Multi-element elliptical-polygonal pocket filters
- Stainless steel filter body, collection hoods and hoppers and collection tubing
- Quick clamp collection tubing for ease of sanitation (requires no tools)
- Heavy duty blower fan
- Large 6" (152 mm) diameter heavy duty rotary airlock
- Hinged filter access door
- Intrinsic grounding system
- Silencer



Polygonal Pocket Filters



6" Diameter Heavy Duty Rotary Airlock



Heavy Duty Blower Fan

ELECTRICAL FEATURES

- Controls integrated into Accupan main system panel
- High-low prox switch
- Sequential stop program for cleaning system
- Fire suppression system integration

OPTIONS

- Custom designed collection hoppers for AMF Accupans
- Custom floor or ceiling support structure for filter body
- Auto flour refill or "wand" fill
- Replacement polygonal pocket filters
- Remote mounted central collector

SPECIFICATIONS

Electrical Requirements: 208/230/460 volts, 3 phase, 60 Hz
 Total Connected Load with 4Kw blower: 5KVA
 Air Requirements: Clean dry air at 90 PSI (6.0 Bar); 20 SCFM (566 L/M)

DIMENSIONAL DRAWING

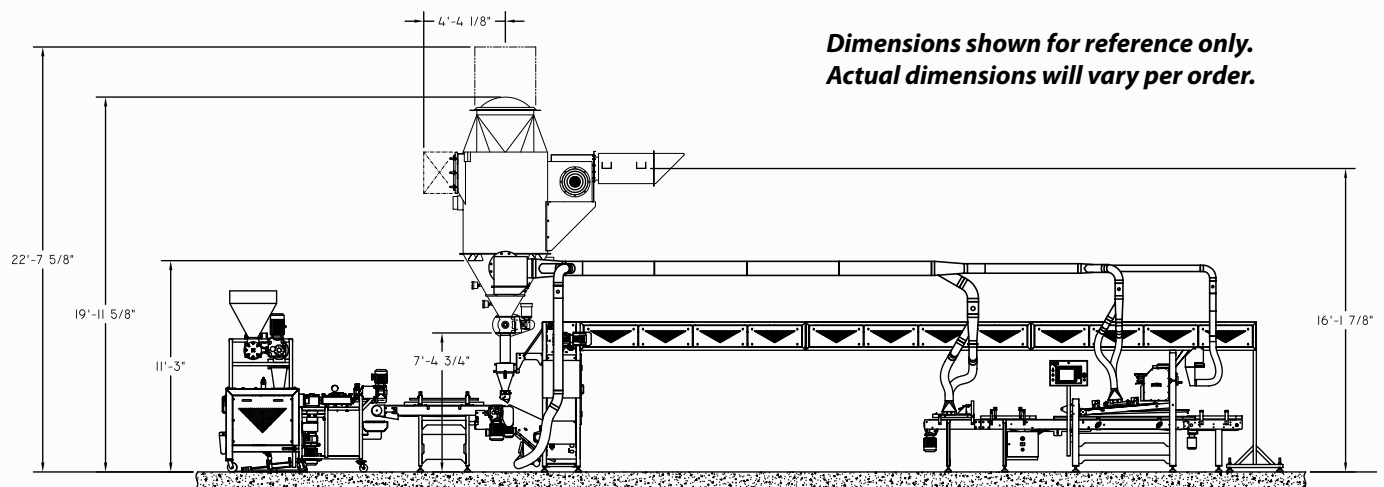

*Dimensions shown for reference only.
 Actual dimensions will vary per order.*

Headquarters:
 2115 W. Laburnum Ave.
 Richmond, Virginia 23227
 Tel: 1-800-225-3771
 or 1-804-355-7961
 Fax: 1-804-342-9724
sales@amfbakery.com

Europe Office:
 6 The Sidings
 Station Road, Guiseley
 Leeds LS20 8BX, England
 Tel: 44-1943-875703
 Fax: 44-1943-871806
sales-europe@amfbakery.com

Asia Office:
 Room 15-2, A-Building
 Thunis Dev. Building
 No.11 Hui Xin East St.
 Chaoyang District
 Beijing, China 100029
 Tel: 86-10-64823613
 Fax: 86-10-64934259
sales-asia@amfbakery.com

FOR MORE INFORMATION PLEASE CALL YOUR ACCOUNT MANAGER OR

1-800-BAKERS-1
www.amfbakery.com

AMF's focus on continuous improvement may result in changes to machinery specifications without notice.