

MODEL U2 DOUGH PUMP



*Shown With Optional Quick Disconnect
Power Plug Assembly and Machine
Mounted Electricals*

- **Exceptional Dough Transfer Technology Featuring AMF's Patented Dual Auger System**
- **Efficient Replacement for Aging High Maintenance Pak-it® and Langsencamp® Pumps**
- **Available in Wide Variety of Hopper and Drive Sizes to Fit Any Production Requirement**

MODEL U2 DOUGH PUMP

FEATURES & BENEFITS

Direct Flow Design

- Eliminates constrictions that cause back pressure and increase dough temperature
- Open auger design eliminates the need for vacuum assist and reduces dough sticking in the hopper

"Dough Friendly" Auger System

- Open flighted augers transfer the dough with high efficiency

- Direct auger drive eliminates pulleys, belts, chains and unnecessary maintenance
- Twin poly screw augers provide dough degassing that improves scaling at the make-up equipment and improves product quality and consistency

Sanitary Design

- The BISSC compliant sanitary framework design speeds clean-up and reduces labor

MECHANICAL FEATURES

- Stainless steel frame and hopper
- Large casters for easy mobility
- Class F insulated Eurodrive gearmotor with direct auger drive
- Twin screw auger design
- Open hopper design that eliminates the need for vacuum systems
- Vertical wall hopper design prevents dough sticking in the hopper
- Direct shaft drive eliminates high maintenance pulleys and belts or sprocket chains



Direct Shaft Drive



Twin Screw Auger Design

ELECTRICAL FEATURES

- NEMA 12 remote enclosure, ANSI 61, gray polyester powder coat finish
- Operator controls mounted in the door of the remote enclosure and include:

- Two-button start
- Stop
- Emergency stop
- MCR reset
- Pump speed
- Auger speed meter
- Inverter fault indicator
- E-stop indicator



Remote Enclosure With Operator Controls

- Inverter drive
- Allen Bradley Micrologix PLC
- Main disconnect switch
- Machine mounted stainless steel junction box

MECHANICAL OPTIONS

- Level control device with mounting bracket
- Dough thermometer option
- 5" (127 mm) diameter discharge pipe in lieu of standard*
- Stainless steel pipe systems*
- CIP "Pig" system
- Driven trolley system between two mixers
- Spare parts kit

* AMF recommends that pipe length be restricted to 10' (3048 mm) with a maximum of two elbows. Pipe lengths in excess of 10' (3048 mm) or more than two elbows will result in a significant maximum throughput reduction and have potential damaging effects to the quality of the final product. AMF recommends that dough conveyors be used where possible for optimum dough pump performance.

ELECTRICAL OPTIONS

- PLC other than standard
- Inverter other than standard
- PLC upgrade for conveyor control from pump
- Remote cleaning starter box
- Quick disconnect power plug assembly
- Pump mounted operator control box option
- CE electrical package
- Stainless steel remote electrical panel in lieu of painted steel



Optional Pump Mounted Station

SPECIFICATIONS

Model	Rated Capacity*	Length**	Width**	Height**	Approximate Shipping Weight
8	800 lb. (363 kg)	47" (1194 mm)	34" (864 mm)	26" (660 mm)	2,050 lb. (930 kg)
10	1,000 lb. (454 kg)	51.75" (1314 mm)	34" (864 mm)	28" (711 mm)	2,150 lb. (975 kg)
13	1,300 lb. (590 kg)	54.75" (1391 mm)	34" (864 mm)	32" (813 mm)	2,250 lb. (1021 kg)
16	1,600 lb. (726 kg)	57.50" (1461 mm)	34" (864 mm)	35.50" (902 mm)	2,350 lb. (1066 kg)
20	2,000 lb. (907 kg)	57.50" (1461 mm)	40" (1016 mm)	35.50" (902 mm)	2,450 lb. (1111 kg)
24	2,400 lb. (1089 kg)	57.50" (1461 mm)	48.50" (1232 mm)	35.88" (911 mm)	2,550 lb. (1157 kg)
28	2,800 lb. (1270 kg)	60" (1524 mm)	48.50" (1232 mm)	40" (1016 mm)	2,600 lb. (1179 kg)
32	3,200 lb. (1452 kg)	62.50" (1588 mm)	48.50" (1232 mm)	42" (1067 mm)	2,650 lb. (1202 kg)

* Rated capacity at 69 lb./ft³

** See drawing on back cover. Custom sizes available.

Electrical Requirements	
Approximate Main Power	
5 HP	5 KVA
7.5 HP	12 KVA
10 HP	15 KVA
15 HP	22 KVA
20 HP	28 KVA
25 HP	33 KVA
30 HP	41 KVA
No air required	

Drive (HP)	Maximum Throughput*
5	2,500 lb./hr. (1134 kg)
7.5	3,750 lb./hr. (1701 kg)
10	5,000 lb./hr. (2268 kg)
15	7,500 lb./hr. (3402 kg)
20	10,000 lb./hr. (4536 kg)
25	12,500 lb./hr. (5670 kg)
30	15,000 lb./hr. (6804 kg)

* May be reduced when handling unusually stiff doughs

DIMENSIONAL DRAWING

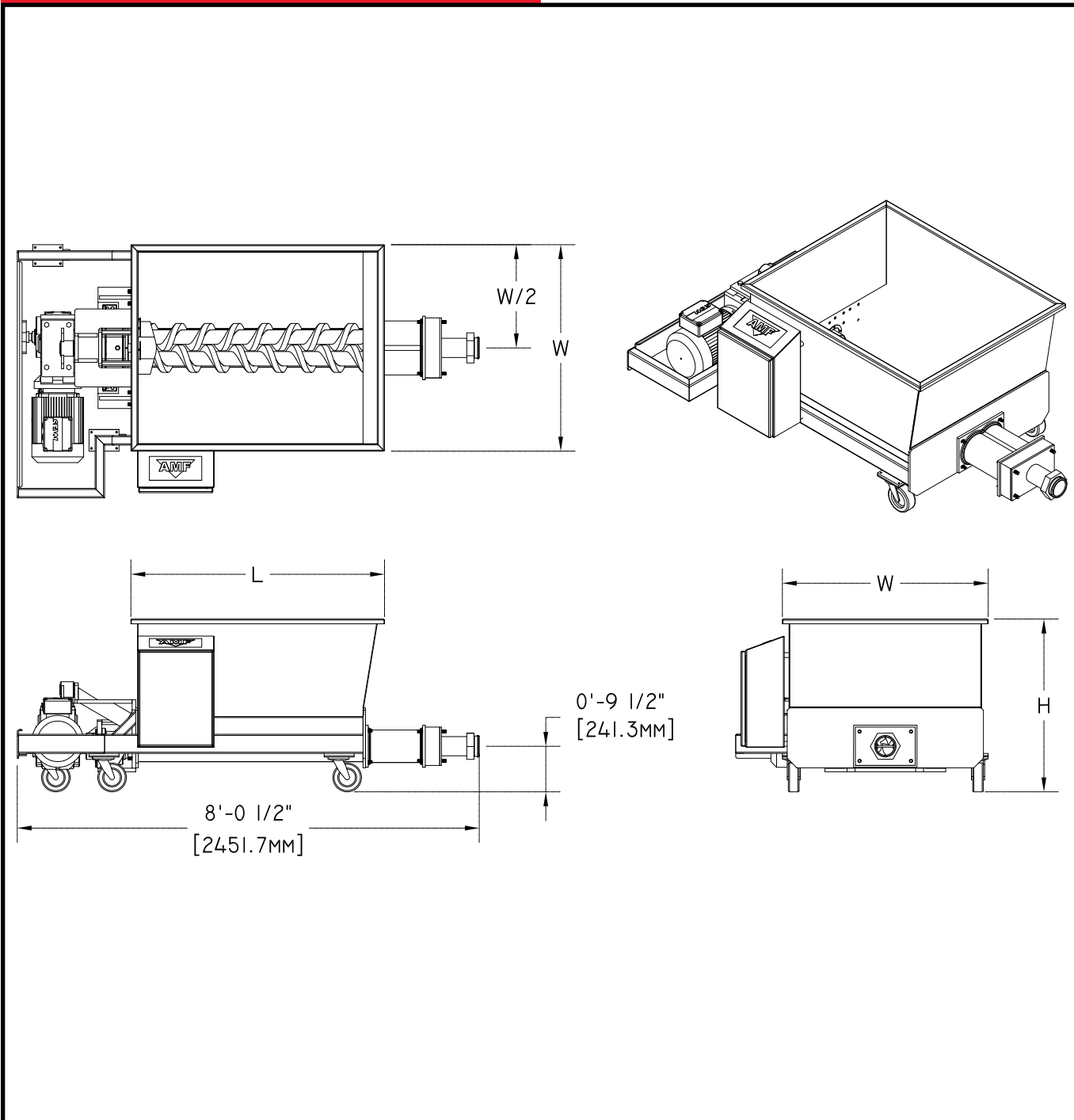

Headquarters:
2115 W. Laburnum Ave.
Richmond, Virginia 23227
Tel: 1-800-225-3771
or 1-804-355-7961
Fax: 1-804-342-9724
sales@amfbakery.com

Europe Office:
6 The Sidings
Station Road, Guiseley
Leeds LS20 8BX, England
Tel: 44-1943-875703
Fax: 44-1943-871806
sales-europe@amfbakery.com

Asia Office:
Room 15-2, A-Building
Thunis Dev. Building
No.11 Hui Xin East St.
Chaoyang District
Beijing, China 100029
Tel: 86-10-64823613
Fax: 86-10-64934259
sales-asia@amfbakery.com

FOR MORE INFORMATION PLEASE CALL YOUR ACCOUNT MANAGER OR

1-800-BAKERS-1
www.amfbakery.com

AMF's focus on continuous improvement may result in changes to machinery specifications without notice.