

# AMF

Packaging - Processing  
**Bid on Equipment**  
1-847-854-8577  
[www.bid-on-equipment.com](http://www.bid-on-equipment.com)

## KX-T DOUGH DIVIDER/ROUNDER



*Optional Hopper Size Shown*



- **Ideal for Tortilla, Frozen and Hard Roll Dough**
- **Quick and Easy Product Changeover**
- **Precision Scaling Accuracy on Entire Range of Products Without Variation from the Beginning to the End of a Dough**
- **Small Footprint for Easy Replacement of Old Drum Divider/Rounders**
- **Single Auger for Gentle Dough Handling at Low Pressure**
- **Available Adjustable Rounding System for a Wide Range of Sizes**

# AMF

## KX-T DOUGH DIVIDER/ROUNDER

### FEATURES & BENEFITS

#### Scaling Accuracy

- Stainless steel metering pump provides greater scaling accuracy than conventional volumetric dividers
- Low pressure manifold with individual port control valves provides estimated  $\pm 1\%$  accuracy

#### Low Maintenance

- Simple design with slow rotating parts requires very little maintenance
- Machine can be run for weeks with no required maintenance downtime

#### Easy Sanitation

- CIP system controlled by the PLC program efficiently cleans all internal product areas
- Complete visual inspection of entire dough path can be performed in minutes with no tools

#### Simple Set-up with Recipe Management

- Change products with the push of a button, adjust machine scaling in seconds
- No change over parts required for different size products

#### Efficient Design and Lower Cost

- Small footprint can replace conventional dividers
- Lower purchase price, low maintenance, no divider oil, all add up to lower operating cost



Quick Clean Manifold

### MECHANICAL FEATURES

- Large 8" (203 mm) UHMW single auger gently urges dough to the metering pump
- Strong 8" (203 mm) stainless steel pump housing for long service life
- No dusting flour needed for dividing or rounding
- 250 lb. (113 kg) capacity stainless steel hopper
  - Round design ensures dough has no corners to hang on
  - First in/first out flow design
  - Easy to clean
- Simple open stainless steel frame design for easy access and sanitation
- Metering pump and manifold mounted on separate cart provides easy access for sanitation and maintenance
- Heavy duty, hollow shaft Nord direct auger drive
- No chains on the entire machine
  - No operating maintenance adjustments required
  - Extremely low maintenance
- Large 8" (203 mm) coupling drive allows auger to be removed in seconds
- Entire design provides slow, simple rotary motions ensuring long service life with low maintenance costs
- Venturi generator based vacuum system for positive pumping action and thorough degassing
- Auger speed controlled by pressure feedback loop for accurate throughput
- Dependable Waukesha stainless steel metering pump with 3" (76 mm) outlet
- UHMW "Quick Clean" scaling division manifold available in 4, 5, 6, 8, or 9 pocket configuration
- Individual stainless steel control valves on each port provide simple, precise scaling control
- UHMW cut-off knife
  - For precise cutting motion up to 110 cuts per minute
  - Optional rotary high speed cut-off for speeds up to 200 cuts per minute
- Dividing system requires *no* divider oil
- Divider unit mounted on heavy duty casters
- Stainless steel rounder frame with direct Eurodrive on belt
- Grooved UHMW rounder bars with AMF floating foot
- Divider can be assembled in either LH or RH configuration
- Rounder must be specified LH or RH



Auger



Hopper, Auger & Transition Block



Metering Pump, Manifold, and Valves



Servo Rotary Cut-off



## ELECTRICAL FEATURES

- NEMA 12 stainless steel control enclosure
  - Mounted on divider and pre-wired for simple installation
- Allen Bradley 5/03 PLC control
  - Synchronizes knife to proofer speed
- Allen Bradley variable speed AC inverters for
  - Auger drive
  - Metering pump drive
  - Rounder belt
  - Kicker roller
- Precise Allen Bradley servo motor drive for cut-off knife
  - Electronic proofer synch kit
- Allen Bradley PanelView 600 operator interface station
  - Full recipe management for up to 50 products
  - Simple changeover procedure
  - Alarm message display
- Allen Bradley pushbuttons for:
  - 2 button start
  - Stop and emergency stop
  - Master control relay
- Alarm beacon
- PLC controlled CIP sanitation routine
- Dough pressure controlled by transducer feedback loop



Machine Mounted Electrical Enclosure & Operator Controls

## OPTIONS

- Optional chilled rounder bed
- Additional machine manuals
- Pneumatic pushback system
  - Allows divider to discharge unwanted dough into rollaway stainless steel catch pan with screen and drain
  - Divider will automatically push back if scaling under weight products based on pressure feedback
  - Pushback also allows easy access during sanitation
- Available adjustable opening rounder bar system for precise rounding control of all dough piece sizes
- Reverse axis rounder bars
- CE electricals



Pushback with Catch Pan



Adjustable Bars

## SPECIFICATIONS

	KX-T 400	KX-T 500	KX-T 600	KX-T 800	KX-T 900
Knife Speed	10 to 135 cuts per minute				
Maximum Ports	4	5	6	8	9
Max Pieces per Hour	32,400	40,500	48,600	64,800	72,900
Total Throughput lb./hr. (kg/hr.)	5,000 (2268)	6,000 (2722)	8,000 (3629)	10,000 (4536)	10,000 (4536)

### Electrical Requirements:

Approximate Main Power: 23 KVA  
 PLC I/O Voltage: 24VDC in/120VAC out

**Air Requirements:** 15 SCFM @ 80 PSIG

### Approximate Shipping Dimensions:

Divider: 116" L x 86" W x 82" H (2947 mm x 2185 mm x 2083 mm)  
 Rounder: 96" L x 84" W x 54" H (2438 mm x 2134 mm x 1372 mm)

### Approximate Shipping Weight:

4,900 lb. (2223 kg)

## KX-T DOUGH DIVIDER/ROUNDER

### DIMENSIONAL DRAWING

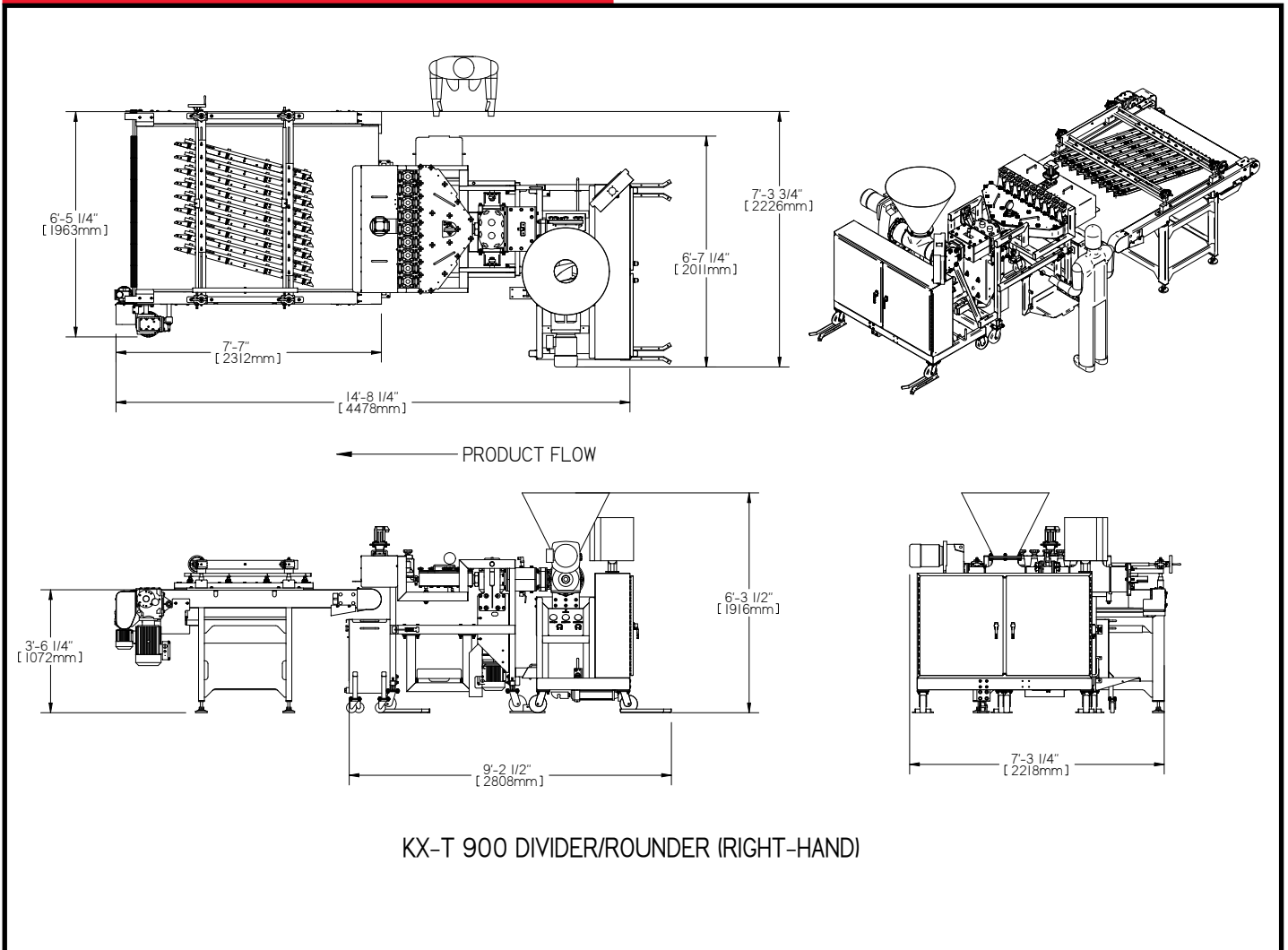

**Headquarters:**  
 2115 W. Laburnum Ave.  
 Richmond, Virginia 23227  
**Tel: 1-800-225-3771**  
**or 1-804-355-7961**  
**Fax: 1-804-342-9724**  
[sales@amfbakery.com](mailto:sales@amfbakery.com)

**Europe Office:**  
 6 The Sidings  
 Station Road, Guiseley  
 Leeds LS20 8BX, England  
**Tel: 44-1943-875703**  
**Fax: 44-1943-871806**  
[sales-europe@amfbakery.com](mailto:sales-europe@amfbakery.com)

**Asia Office:**  
 Room 15-2, A-Building  
 Thunis Dev. Building  
 No.11 Hui Xin East St.  
 Chaoyang District  
 Beijing, China 100029  
**Tel: 86-10-64823613**  
**Fax: 86-10-64934259**  
[sales-asia@amfbakery.com](mailto:sales-asia@amfbakery.com)

FOR MORE INFORMATION PLEASE CALL YOUR ACCOUNT MANAGER OR

**1-800-BAKERS-1**  
**www.amfbakery.com**

AMF's focus on continuous improvement may result in changes to machinery specifications without notice.