

DIRECT DRIVE MIXER (DDM)



- Open Frame Design
- Direct Drive Agitator
- Triple Roller Bar Design for Mixing Breads, Rolls, Buns, Flour Tortillas, English Muffins, Bagels, Pizza Crusts, Frozen Doughs and Sweet Goods

FEATURES AND BENEFITS

- Open frame design allows easy access for routine maintenance and sanitation
- Direct drive agitator design eliminates belts and chains which reduces maintenance and lubrication requirements and provides a quieter drive
- AC variable speed drive system for maximum mixing speed control
- Refrigeration bowl jacket with a unique channeling design offers greater heat transfer for superior cooling
- Touchscreen operator interface, PLC controls and pushbuttons for frequent operator functions

MECHANICAL FEATURES

Frame Assembly

- Stainless steel open frame design
- Heavy duty stainless steel canopy with sliding flour gate and liquid inlets
- Anti-vibration pads

Bowl and Cooling Jacket

- 120° bowl tilt system
- Heavy duty stainless steel bowl
- Dual circuit jacket designed for reduced pressure drop and high efficiency glycol cooling. Pressure tested at 150 PSI
- Bowl is insulated with urethane foam covered with a welded stainless steel sheet.
- Bowl rests on low maintenance nylatron bushings.
- Refrigeration hoses and manual ball valves included



Mechanical Tilt Mechanism

Agitator and Drive Assembly

- Solid stainless steel Y type spiders split at main shaft and agitator bars
- Stainless steel primary agitator bars mounted on lubrication free UHMW bushings
- Main shaft seals are easily removable and fabricated of polyethylene for exceptional durability. This new type of seal allows easy cleaning.
- Solid stainless steel breaker bar (four adjustable positions)
- Heavy duty stainless steel main shaft
- Eurodrive gearmotor drive system



Sanitary Main Shaft Seal

Top Assembly

- 12" (305 mm) O.D. butterfly or sliding flour gate
- Two stainless steel liquid inlets
- Canopy scraper
- Flour vent

Tilting Assemblies

- Mechanical tilt design including:
 - Integral gearhead brake motor with chain and sprockets
 - Air driven caliper and disk bowl lock mechanism

ELECTRICAL FEATURES

Operator panel is NEMA 4X rated and contains the following:

- Allen Bradley PanelView operator interface which displays:
 - Mixing and refrigeration time
 - Dough temperature
 - Status and alarm messages
 - Editable Product codes and recipes
 - Total operation time clock
- Allen Bradley push-buttons for the following functions:
 - Mixing (slow, fast, stop)
 - Tilting (lower, raise, stop)
 - Alarm (acknowledge/reset)
 - Safety
 - Emergency stop

NEMA 12 remote enclosure (painted steel) including:

- Main breaker
- AC variable speed drive
- Allen Bradley PLC
- Mixer and refrigeration mode selection from operator interface
- Timer and setpoint based temperature control modes included
- Latching safety devices on ingredient and access doors interlocked with agitator motion monitor
- Standard voltage 460 and 600 volts / 3 Phase / 60 Hz (other voltages available)
- PLC I/O Voltage: 24VDC in/24VDC out

MECHANICAL OPTIONS

- Bowl drain valve
- Lip extension
- Y-T asymmetrical full split stainless steel agitator
- Extra liquid inlet
- Additional flour inlet (available only with butterfly valve)
- Rear sponge door, air operated hinge type
- Rear ingredient door with safety bars and agitator motion interlock
- Stainless steel full length legs up to 24" (610 mm)
- Automatic central lubrication system
- Trough hold down mechanism, manual or air operated



Optional Y-T Agitator

ELECTRICAL OPTIONS

- Ammeter or wattmeter to display motor load
- Dough quality monitor to trend agitator motor energy and reference to pre-recorded curves
- Remote pedestal mount stainless steel operator console
- Stainless steel main electrical enclosure
- PLC and operator interface upgrades

DIRECT DRIVE MIXER (DDM)

DIMENSIONAL DRAWING

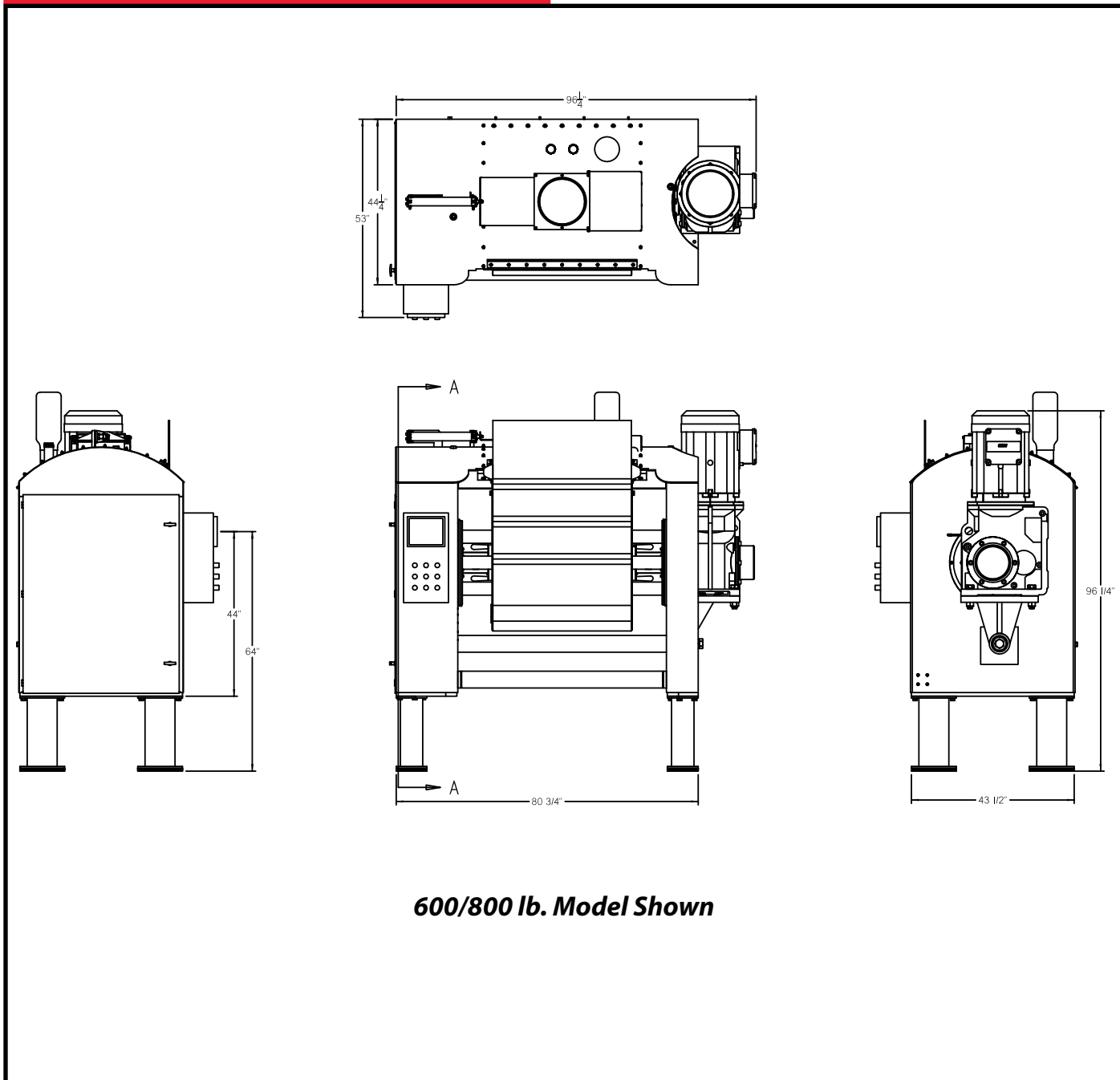

600/800 lb. Model Shown

Headquarters:
2115 W. Laburnum Ave.
Richmond, Virginia 23227
Tel: 1-800-225-3771
or 1-804-355-7961
Fax: 1-804-342-9724
sales@amfbakery.com

Europe Office:
6 The Sidings
Station Road, Guiseley
Leeds LS20 8BX, England
Tel: 44-1943-875703
Fax: 44-1943-871806
sales-europe@amfbakery.com

Asia Office:
Room 15-2, A-Building
Thunis Dev. Building
No. 11 Hui Xin East St.
Chaoyang District
Beijing, China 100029
Tel: 86-10-64823613
Fax: 86-10-64934259
sales-asia@amfbakery.com

FOR MORE INFORMATION PLEASE CALL YOUR ACCOUNT MANAGER OR

1-800-BAKERS-1
www.amfbakery.com

AMF's focus on continuous improvement may result in changes to machinery specifications without notice.