

AMF

Packaging - Processing
Bid on Equipment
1-847-854-8577
www.bid-on-equipment.com

CYCONE BREAD ROUNDER



- **Two stage rounding for precise sphere shaping. The cylindrical stage initiates the round shape and the conical stage finishes the dough piece into a precise round shape.**
- **This rounder is designed to provide precise dough rounding for a wide range of bread doughs including specialty, whole wheat, rye, cinnamon raisin and white.**
- **1³/₄, 2¹/₄, 2¹/₂ CCW turns available**

AMF

CYCONE BREAD ROUNDER

FEATURES & BENEFITS

- Combined action of cylindrical and conical rounding for perfect dough ball shape. The roundness of the dough piece is critical to proper sheeting and moulding process. It also helps seal the fermentation gases inside doughball. This directly affects product quality and process performance.
- Aggressive cone angle with 54" (1372 mm) diameter base increases effective rounding path
- Special non-stick coating and plastic materials for dough contact surfaces improve product quality and minimize dusting flour usage and facilitate cleaning
- Independent, adjustable trough sections allow rounding track width adjustment for wider range of product sizes
- Independent "shaft mount" drives eliminate drive chains, reducing maintenance
- Wide, heavy duty support frame provides greater cone stability reducing waste from "run out"

MECHANICAL FEATURES

Frame Assembly

- Painted steel, wide base support structure and stainless steel guards
- Rigid stainless steel upper frame tubing structure
- Stainless steel catch pan

Rounding System

- Adjustable speed, 5 HP motor with V belt drive system
- Non-stick coated, machined steel cone on stainless steel shaft and heavy duty bearings
- Non-stick coated, adjustable aluminum tracks
- Non-stick coated, stainless steel dough ball discharge chute (90°)



*Non-Stick Coated
Combination Cylindrical
and Conical Rounding
Surface with Adjustable
Rounding Track*



V Belt AC Cone Drive

MECHANICAL OPTIONS

- AC adjustable speed infeed conveyor
- Infeed deflector roller
- AC adjustable speed discharge conveyor
- AC adjustable speed discharge kicker roller
- AC adjustable speed, removable, high capacity flour duster



*Optional AC Drive
Kicker Roller, Discharge
Conveyor & Flour Sifter*



ELECTRICAL FEATURES

Operator panel is stainless steel NEMA 4 rated and contains the following:

- Allen Bradley PanelView 300 operator interface which displays:
 - Machine start and stop
 - Operation speed
 - Status, alarm and history messages
- Allen Bradley push buttons for the following functions:
 - Alarm acknowledge/reset
 - MCR reset
 - Emergency stop



*Machine Mounted
Operator Control Station*

NEMA 12 enclosure (painted steel) including:

- Main power disconnect
- Allen Bradley MicroLogix 1100 programmable logic controller
- Allen Bradley AC inverter for main drive

ELECTRICAL OPTIONS

- NEMA 4X stainless steel main electrical enclosure
- Processor and operator interface upgrades

SPECIFICATIONS

Throughput Range:

Scaling range from 12 oz. (340 g) to 40 oz. (1134 g) at 65 lbs/ft³ dough density

Rounding Track Length:

1 3/4 turn model - 256" (6052 mm)

2 1/4 turn model - 316" (8026 mm)

2 1/2 turn model - 340" (8636 mm)

Up to 180 units per machine depending on scaling weight and product

Electrical Requirements:

17 KVA

Standard voltage: 460 volts/3 phases/60 Hz
(other voltages available)

PLC I/O Voltage: 24VDC in/120VAC out

Approximate Shipping Dimensions:

88" L x 53" W x 56" H (2235 mm x 1346 mm x 1422 mm)
Infeed height approximately 33" (838 mm)

Discharge Height:

1 3/4 turn model - approximately 50 1/2" (1283 mm)

2 1/4 turn model - approximately 58 1/2" (1486 mm)

2 1/2 turn model - approximately 62 1/2" (1588 mm)

Approximate Shipping Weight:

3000 lbs. (1361 kg)

DIMENSIONAL DRAWING

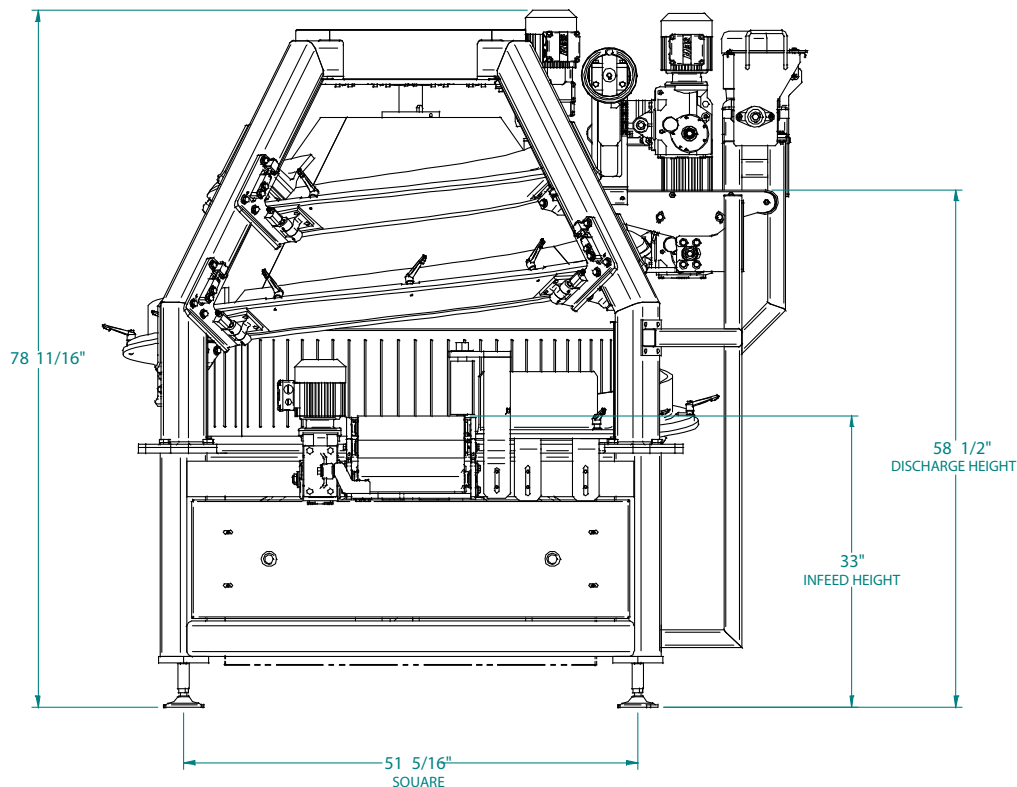
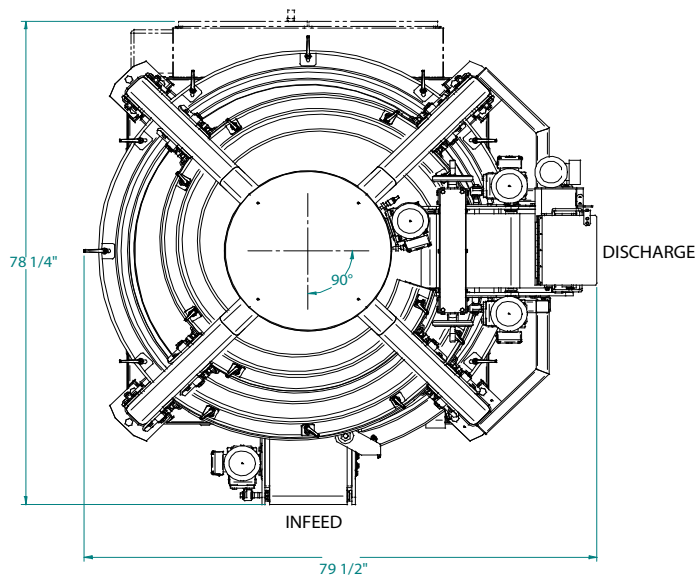

Headquarters:
2115 W. Laburnum Ave.
Richmond, Virginia 23227
Tel: 1-800-225-3771
or 1-804-355-7961
Fax: 1-804-342-9724
sales@amfbakery.com

Europe Office:
6 The Sidings
Station Road, Guiseley
Leeds LS20 8BX, England
Tel: 44-1943-875703
Fax: 44-1943-871806
sales-europe@amfbakery.com

Asia Office:
Room 15-2, A-Building
Thunis Dev. Building
No.11 Hui Xin East St.
Chaoyang District
Beijing, China 100029
Tel: 86-10-64823613
Fax: 86-10-64934259
sales-asia@amfbakery.com

FOR MORE INFORMATION PLEASE CALL YOUR ACCOUNT MANAGER OR

1-800-BAKERS-1
www.amfbakery.com

AMF's focus on continuous improvement may result in changes to machinery specifications without notice.