

AMF

Packaging - Processing
Bid on Equipment
1-847-854-8577
www.bid-on-equipment.com

BOTTOM-UP BASKET STACKER



- **Automatically Stacks Up to 28 Baskets Per Minute With Accurate, Consistent Stacking of All Types of Baskets (Speed Can Be Increased with Pre-Stacker)**
- **Superior Response to System Demand With Programmable Controller and Automatic Positioning Discharge for Optional Stack Handling**

AMF

BOTTOM-UP BASKET STACKER

FEATURES & BENEFITS

Ergonomic, User Friendly Design

- Menu-driven controls for ease of use
- Easily accessible solenoid valves for adjustment of speed control
- Quality materials and components assure high performance, minimum maintenance, and longevity
- Factory-tested, programmed and ready to install

Versatility and Accuracy

- Motorized driven lift and stacking mechanism
- Basket Stacker can serve both bread and bun lines
- Adjustable width option for different size baskets
- Accumulates baskets during stack discharge, stacking level can be preset to a specific count and automatically discharged

MECHANICAL FEATURES

- Feed conveyor
- Motorized lift assembly
- Stack discharge area
- Integrated controls



Basket Lifting Detail



Basket Stacker Detail



Exit Basket Stacker

ELECTRICAL FEATURES

Individual basket feed, motorized lift and full stack exit systems are all fully integrated to provide a trouble free automated stacking system

- Allen Bradley PLC
- Allen Bradley Operator Interface
- Allen Bradley push buttons for the following functions:
 - Start
 - Stop/Emergency stop
 - MCR reset



OPTIONS

- Stainless steel enclosure
- Panel cooling
- Interface options
- PLC options
- Adjustable basket width option
- Adjustable basket length option
- Wrong way basket detection
- Right or left hand operator interface location
- Stack discharge stop

SPECIFICATIONS

Speed	Maximum Basket Height	Maximum Rate (baskets/min.)	Baskets/Min. with Pre-Stacker
Low	7" (178 mm)	12	N/A
Medium	5" (127 mm)	20	N/A
High	3" (76 mm)	28	34

Electrical Requirements:

Main Power: 6 KVA

PLC I/O Voltage: 24 VDC in/120 VAC out

Air Requirements: 1/2 SCFM @ 80 PSIG

Approximate Shipping Dimensions:

96" x 65" x 82" (minus mast) x 124" (with mast)

2438 mm x 1651 mm x 2083 mm (minus mast) 3150 mm (with mast)

Approximate Shipping Weight:

2,300 lb. (1043 kg)

BOTTOM-UP BASKET STACKER

DIMENSIONAL DRAWING

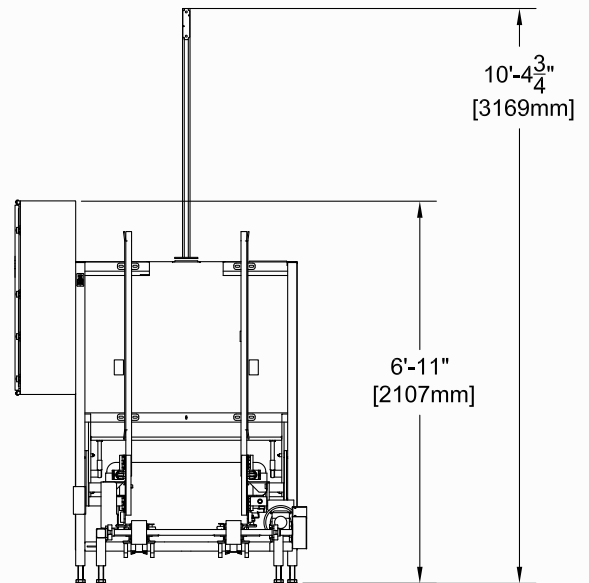
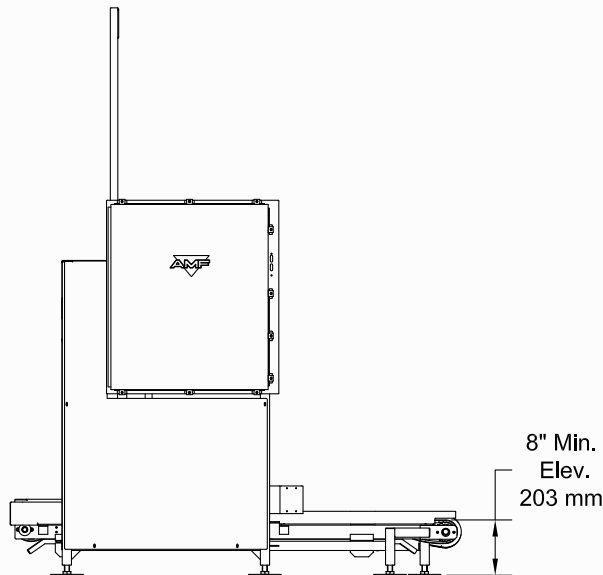
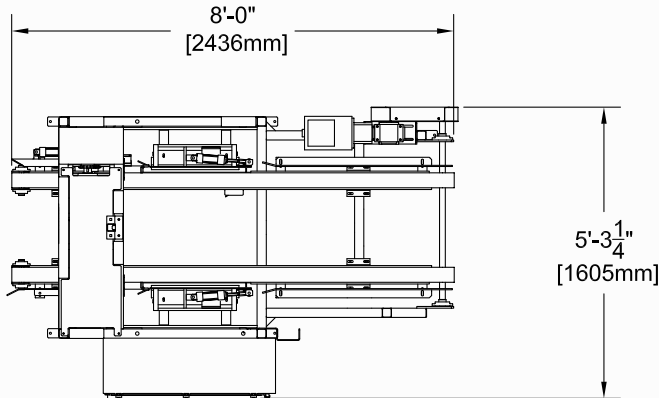

Headquarters:
2115 W. Laburnum Ave.
Richmond, Virginia 23227
Tel: 1-800-225-3771
or 1-804-355-7961
Fax: 1-804-342-9724
sales@amfbakery.com

Europe Office:
6 The Sidings
Station Road, Guiseley
Leeds LS20 8BX, England
Tel: 44-1943-875703
Fax: 44-1943-871806
sales-europe@amfbakery.com

Asia Office:
Room 15-2, A-Building
Thunis Dev. Building
No.11 Hui Xin East St.
Chaoyang District
Beijing, China 100029
Tel: 86-10-64823613
Fax: 86-10-64934259
sales-asia@amfbakery.com

FOR MORE INFORMATION PLEASE CALL YOUR ACCOUNT MANAGER OR

1-800-BAKERS-1
www.amfbakery.com

AMF's focus on continuous improvement may result in changes to machinery specifications without notice.