

# AMF

## ACCUMAX ROLL DIVIDER



- **Soft Roll Extrusion Bun Divider Design**
- **Ultra Low Shear Metering for Improved Product Quality**
- **Built-in Developer for Improved Product Consistency and Scaling**
- **Direct Replacement for K-Heads and Early Generation Extrusion Roll Dividers**

### FEATURES & BENEFITS

#### Superior Scaling Accuracy

- AMF's new generation extrusion technology
- 200-300% more accurate scaling than a conventional K-Head divider increases production yield
- Scaling remains consistent over the life of the divider - 15 years or more, with proper maintenance

#### Dough Friendly Design

- A built-in developer system provides additional production flexibility to optimize quality
- "Peristaltic" motion metering pump to control throughput without shear and with 100% purge per resolution, ensuring "first-in, first-out"
- E-Z flow distribution manifold is a "valveless" design to control scaling weight without increasing back pressure
- A rotary motion cut-off provides a gentle slicing action

#### Reduced Operating Cost

- No divider oil required, which reduces operating and sanitation costs

- Efficient design with 40% fewer moving parts than a K-Head for reduced maintenance cost
- Rotary design on the feed screw, developer, metering pump, and cut-off provide a service life that is 3-4 times longer than a conventional divider. In addition, it provides a low operating noise level (under 80 dB).
- An electronic clean cycle and open access to all operating components allow for easier sanitation and maintenance

#### Improved Automation for the Entire Make-Up System

- An operator interface-based recipe management system ensures consistent and repeatable automated divider set-up
- A servo synchronization system tied into the Pan-O-Mat allows the AccuMax recipe management system to synchronize with the Pan-O-Mat

## ACCUMAX ROLL DIVIDER

### MECHANICAL FEATURES

- Heavy duty stainless steel frame for durability and corrosion resistance
- Patented quarter block system provides quick and simple port blocking
- Polished stainless steel guards and hopper for easy sanitation
- Stainless steel feed screw and developer housing for durability and minimum dough flow resistance
- Feed screw, developer, and metering pump have direct coupled drives, no chains or pulleys
- All major drives are severe duty gearmotor drives
- Integral stainless steel dough developer
- Stainless steel metering pump for precise, linear flow control with ultra low shear peristaltic action
- E-Z flow distribution and scaling manifold features internal flow diverters to precisely balance flow without additional back pressure. Diverters are adjustable by external adjusters with location indicators.
- Patented quick clean manifold
- Individual UHMW cut-off knives slice clearly, without tearing gluten stands and provide precise doughball placements at any speed
- Easy access to all operational areas, no tools required for sanitation
- Manually actuated divider pushback employs a large air cylinder for slow, steady movement of the divider from the rounder and allows for easy maintenance and sanitation access to the cut-off area.
- A PLC actuated divider pushback is also supplied that will automatically push the divider back in case of pressure loss to prevent under scaled product from entering the make-up system. A removable catch pan is provided to collect the dough pieces for recycling to the divider.
- A PLC controlled venturi-style vacuum system provides for efficient pumping and degassing
- Simple quarter turn valve for fast "no tools" port block off



Patented Quick Clean Manifold

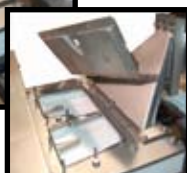

Built-In Developer and Gentle Sine Metering Pump



AccuMax Cut-Off Assembly



EZ Flow Manifold with Vane Adjustment Indicators

### ELECTRICAL FEATURES

Operator panel includes the following:

- Allen Bradley PanelView Plus operator interface to control:
  - Developer speed
  - Feed screw speed
  - Metering pump speed
  - Vacuum pressure
  - Alarm messages
  - Product codes
- Allen Bradley pushbuttons for:
  - Two-button start
  - Stop/Emergency stop
  - MCR reset
- NEMA 12 remote electrical enclosure (painted steel) including:
  - Main disconnect switch
  - Allen Bradley CompactLogix
  - Allen Bradley Powerflex
- Closed loop pressure control system with pressure transducer
- PLC controlled clean-in-place system for reduced sanitation cost
- Servo drive cut-off knife to synch with existing proofer



Operator Interface Panel



## OPTIONS

- Divider mount swing arm for operator panel
- Pushback rail system to mount on existing rounder frame in lieu of floor cart
- PLC in lieu of Allen Bradley CompactLogix
- Spoofer drive kit with inverters speed control
- Stainless steel electrical panel in lieu of painted
- Panel modem for remote diagnostics
- CE confirmed electrical package
- Inverters in lieu of Allen Bradley PowerFlex
- Operator interface in lieu of Allen Bradley PanelView Plus
- Extrusion type non-stick rounder belt
- Spiral tunnel rounder bars
- Hinged rounder bar lift kit
- Product memory increase
- Rounder AC speed control package
- Hopper in lieu of standard
- Stainless steel chilled rounder bed
- Pneumatic "pulse" flour sifter kit to integrate with flour recovery system
- Zig-zag rotary gate kit
- Magnetic pan indexer with integral recipe management
- Spare parts kit



*Pushback Rail System*

## SPECIFICATIONS

Model	Maximum Throughput Range	Scaling Range	Speed Range*	Approximate Shipping Dimensions	Approximate Shipping Weight
AccuMax 400	6,000 lb./hr. (2722 kg/hr.)	7/8 oz. to 6 oz. (25 g to 170 g)	40 - 125 cpm	66" x 72" x 49" (1676 mm x 1829 mm x 1245 mm)	2,170 lb. (984 kg)
Electrical Panel				48" x 88" x 26" (1219 mm x 2235 mm x 660 mm)	
AccuMax 600	7,500 lb./hr. (3402 kg/hr.)	7/8 oz. to 6 oz. (25 g to 170 g)	40 - 125 cpm	66" x 72" x 49" (1676 mm x 1829 mm x 1245 mm)	2,270 lb. (1030 kg)
Electrical Panel				48" x 88" x 26" (1219 mm x 2235 mm x 660 mm)	

\* Gearmotors are sized to meet specific production requirements, therefore the divider will be geared to handle a specific range of production.

**Electrical Requirements:**

Approximate Main Power - 23KVA

PLC I/O Voltage - 24VDC in/120VAC out

**Air Requirement :** 15 SCFM @ 80 PSIG



# ACCUMAX ROLL DIVIDER

## DIMENSIONAL DRAWING

AIR DROP #	AIR REQUIREMENTS	CONNECTION	MACHINE
⊗ A1	25 SCFM 87 PSI	708 L/M 6.0 BAR	1/2 NPT ACCUMAX
⊗ A2	15 SCFM-MIN. 80 PSI 25 SCFM-MAX. 100 PSI	425 L/M 5.6 BAR 708 L/M 6.9 BAR	1/2 NPT EXAIR PANEL COOLER

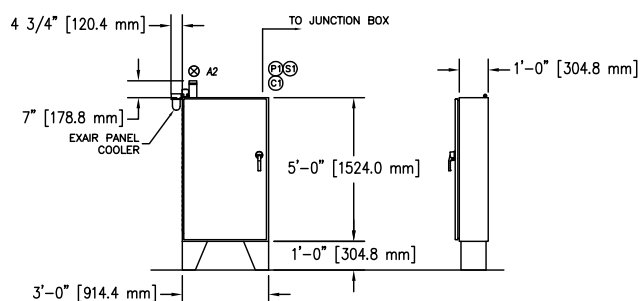

ACCUMAX ELECTRICAL CONTROL PANEL – REMOTE MOUNT  
 ENCLOSURE, PAINTED

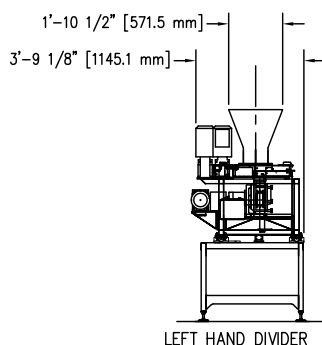
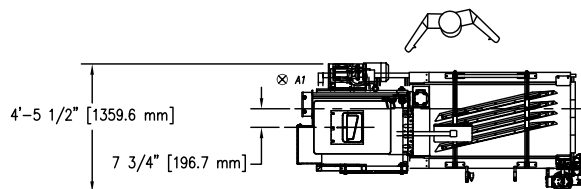

LEFT HAND DIVIDER

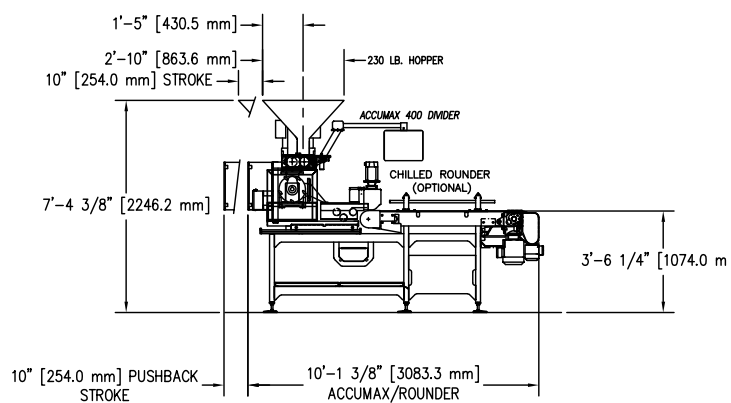

**Headquarters:**  
 2115 W. Laburnum Ave.  
 Richmond, Virginia 23227  
**Tel: 1-800-225-3771**  
 or 1-804-355-7961  
**Fax: 1-804-342-9724**  
[sales@amfbakery.com](mailto:sales@amfbakery.com)

**Europe Office:**  
 6 The Sidings  
 Station Road, Guiseley  
 Leeds LS20 8BX, England  
**Tel: 44-1943-875703**  
**Fax: 44-1943-871806**  
[sales-europe@amfbakery.com](mailto:sales-europe@amfbakery.com)

**Asia Office:**  
 Room 15-2, A-Building  
 Thunis Dev. Building  
 No.11 Hui Xin East St.  
 Chaoyang District  
 Beijing, China 100029  
**Tel: 86-10-64823613**  
**Fax: 86-10-64934259**  
[sales-asia@amfbakery.com](mailto:sales-asia@amfbakery.com)

FOR MORE INFORMATION PLEASE CALL YOUR ACCOUNT MANAGER OR

**1-800-BAKERS-1**  
**www.amfbakery.com**

AMF's focus on continuous improvement may result in changes to machinery specifications without notice.