

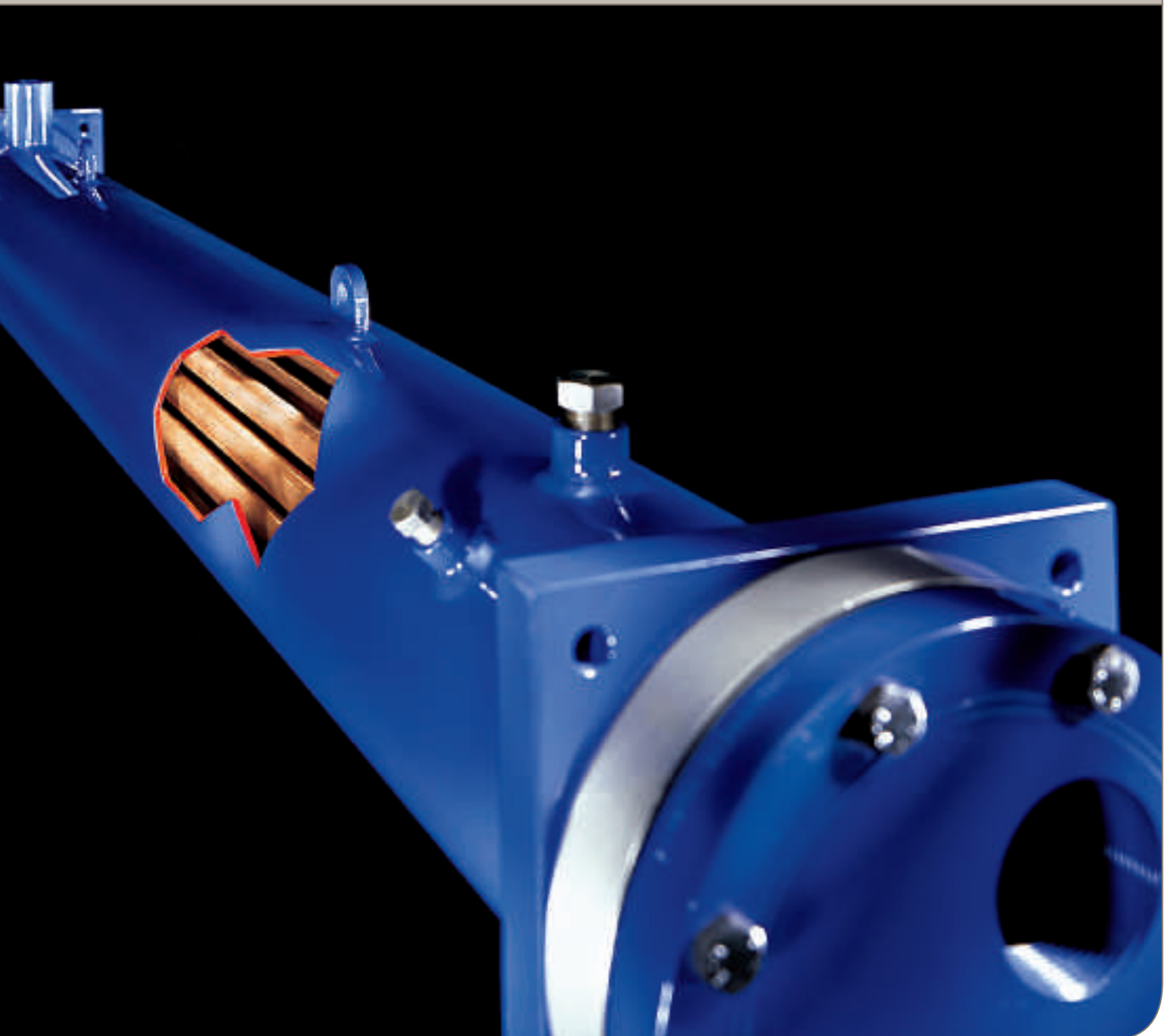

Water cooled condensers

Shell and tube condensers for fresh and sea water applications



Water cooled condensers

- 3 The widest range
 - A world of applications
- 4 Features & Benefits
- 5 The perfect solution for R407C
 - Performance on a wide range
 - When efficiency is a must
- 6 Highest level in component design and manufacturing quality
 - Quality tests and pressure vessel approvals
- 7 Versions
 - Sea water for a trouble-free condensation
- 8 Where the water flows
 - The ideal choice, when maintenance is needed
 - Fittings
- 9 Technical data: Fresh water
- 10 Technical data: Sea water
- 11-12 CDEW dimensions
 - 13 CDEW-E dimensions
- 14-15 CPS dimensions
 - 16 CFL dimensions
 - 17 CRS dimensions
 - 18 ACFL dimensions
 - 19 McDEW dimensions
- 20 Refrigerant connections
 - 21 CDEW/CDEW-E/McDEW refrigerant connections
- 22-23 Water connections

The widest range

Alfa Laval's shell and tube production includes a wide range of condensers and desuperheaters with 8 different series providing individual solutions for each conditioning, refrigeration and cooling application. Standard models fulfil condensation capacities ranging from 3 to 900 kW and 1680 kW can easily be reached with the extension of the new CDEW series. The different condenser series have been carefully optimised for the most used HFC refrigerants. All condenser models can be opened for inspection and maintenance purposes. CFC, CRS, CPLUS, ACFL and CDEW series are designed to operate with fresh water and CFC/M and McDEW series

are dedicate to sea water applications thanks to material selection and correct sizing in order to prevent fouling and corrosion. All condenser models can be supplied in HR desuperheater version for water heating in a partial or total heat recovery system. Thanks to HRC configuration, CDEW and CPLUS can be supplied with two heat exchanger assembled in one shell. This configuration allows to operate alternatively the condenser and the total heat recovery functions. Alfa Laval quality systems are certified in accordance with ISO9001 from TÜV-D, a further warranty of the shell and tube condenser's high quality level.

A world of applications

Alfa Laval's shell and tube condensers represent the optimal solution for all the application where HFC condensation is required. Water cooled chillers and heat pumps for air conditioning or industrial cooling in combination with several types

of processes. Commercial and industrial refrigeration plants with water condensation. On-board or all the other applications where sea, lake or river water is available.



Air Conditioning



Process Cooling



Commercial and Industrial Refrigeration

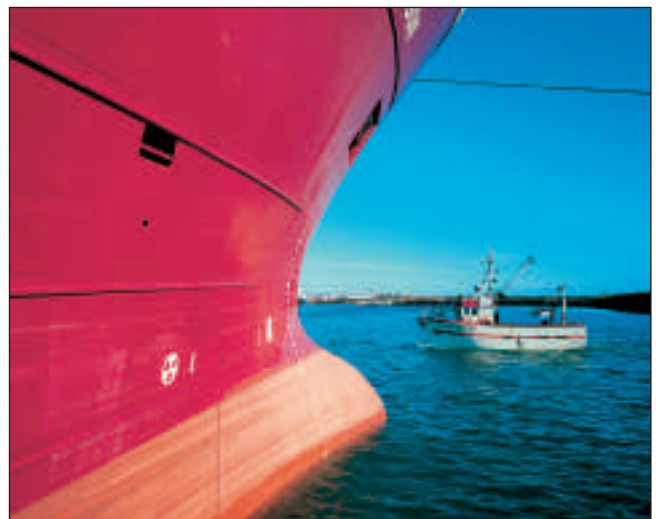

Marine

- 1** High performances due to special design finned Cu and Cu/Ni tubes and tube geometry.
- 2** 8 different condenser series for a total of 121 models: the correct solution for each application.
- 3** The only shell and tube condenser series optimised for R407C.
- 4** 2 passes & 4 passes version.
- 5** Easy installation.
- 6** Desuperheater version.
- 7** All models can be opened for inspection & maintenance
- 8** Solutions for applications with fresh water & sea water
- 9** All the most diffused pressure vessel approvals are available as a standard. Specific approvals available on request.
- 10** Every single condenser is pressure & leak tested before delivery ensuring top quality products.



Header configuration

Tube sheet

Metal ring

Front cover

Front gasket (EPDM)



CDEW series of shell and tube condensers has been optimised by Alfa Laval's R&D dept. and Laboratory in order to ensure the highest performance with HFC-R407C. This refrigerant is particularly affected by glide and this phenomenon can be relevant during the condensing phase causing losses in performance if standard condensers designed to operate with azeotrop refrigerant are used. Thanks to its special design and sizing, CDEW condensers can now reduce 3K

the condensation temperature with respect to the standard condenser series. In a water chiller this means:

- COP improvement +11%
- Input power -6%

Also supports and brackets costs are reduced by the condenser square tube sheets that provide a simple and cheap solution.

Performance on a wide range

The new CDEW series capacity range is from 57 to 840 kW with standard models and up to 1680 kW. CDEW shell and tube heat exchangers are available in condenser and desuperheater version in order to provide partial or total heat reco-

very in cooling systems. CDEW heat exchangers are available in accordance with the major pressure vessel codes as CE (Europe), GOST (Russia), SQL (China), ASME (USA).

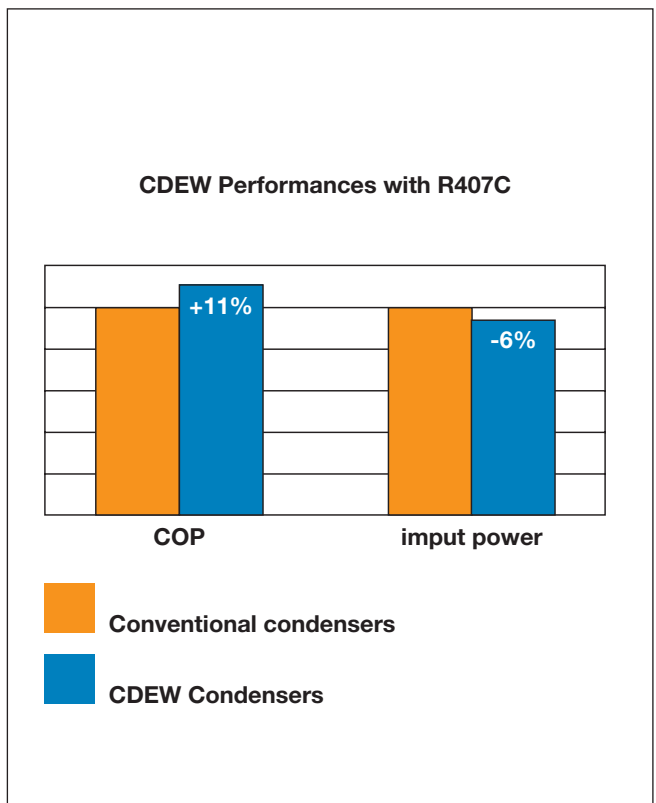
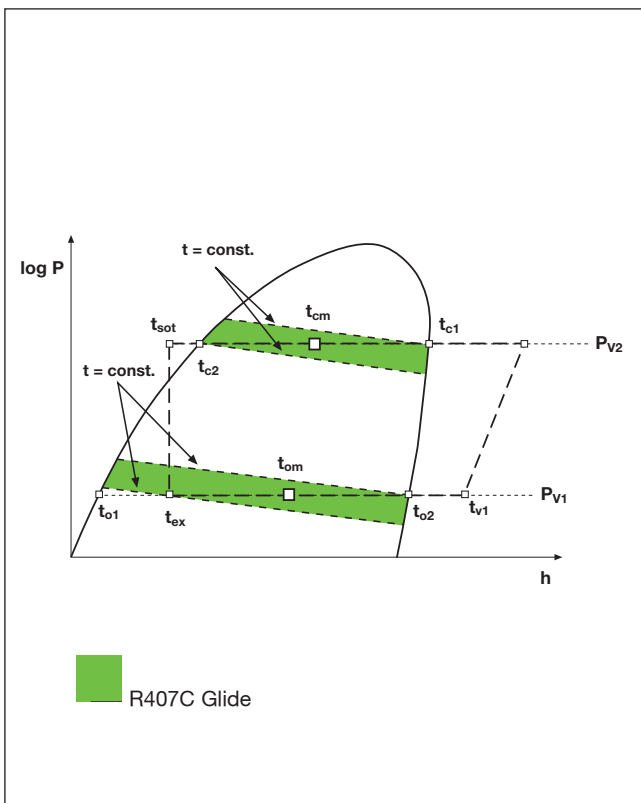

When high efficiency is a must

The request for high efficiency chillers, based both on dry expansion or on flooded evaporation technology, is dramatically increasing. R134a refrigerant is more and more selected in order to design high COP cooling systems saving energy and ensuring to the final users important advantages in comparison with conventional systems. The target to reduce the

approach between the condensing temperature and the water outlet temperature is behind the CDEW-E project. This condenser series represents Alfa Laval contribution to high COP chiller projects, dedicated to R134a, ensuring low condensing temperatures and allowing at the same time 3K subcooling.

Models designed for fresh water applications (series CFC, CRS, ACFL, CPLUS and CDEW) use the following components:

- Shell: carbon steel
- Tube sheets: carbon steel
- Tubes: integrally finned thick wall copper tubing
- Covers: carbon steel
- Gasket: thermopolymer compound
- Baffles: teflon

All the carbon steel components are sand blasted, inclu-

ding the internal wall of the shell. The precise fit of the tube exchanger baffle eliminates the risk of copper filings collecting. Models belonging to series CFC, CRS and ACFL on request can be manufactured in stainless steel execution. The new header configuration for CPLUS and CDEW allows an increase in water pressure to 10 bar. The special gasket configuration resists high pressure and gives the best resistance to ageing in the working temperature range. For models with shell diameter larger than 219 mm a sight glass is available as an option.

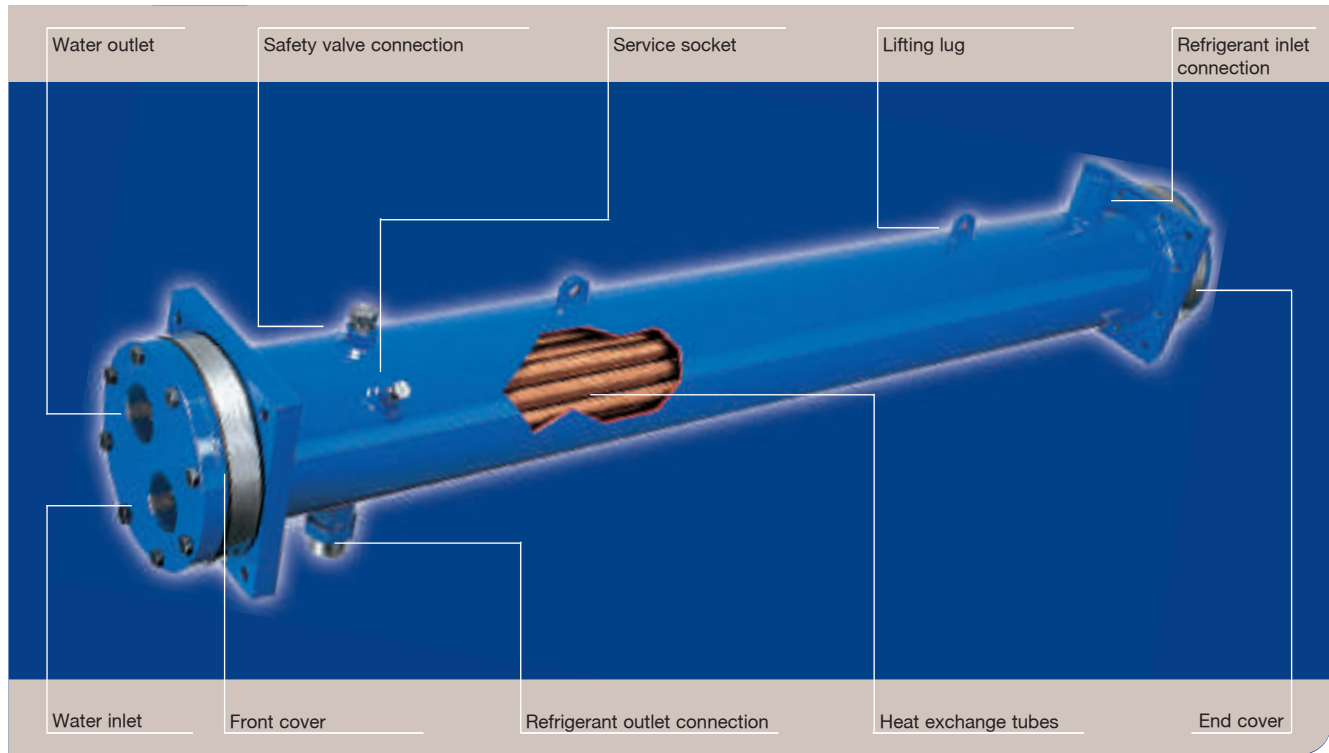

Quality tests and pressure vessel approvals

The working limits are defined by the design pressure (i.e. the maximum working pressure) and the working temperature range. These limits depend on the pressure vessel approval required. Alfa Laval's condensers are available as a standard with the most diffused pressure vessel approvals. On request

marine or other specific approvals are available. Alfa Laval shell and tube condensers are manufactured in accordance with ISO9001. Each unit undergoes an individual pressure and leak test as specified by the relevant authority and in accordance with Alfa Laval internal quality procedures.

NOMINAL DATA		ALFA LAVAL (self inspected)	CE (Directive PED 97/23 EC)	ASME OD ≥ 6"	SQL	GOST
Design pressure refrigerant side ¹⁾	bar	30	30	30	30	30
Test pressure refrigerant side ²⁾	bar	33	43	45	43	43
Design temperature ref. ³⁾	°C	-20/+120	-20/+120	-10/+90	-20/+120	-20/+120
Design pressure water side ⁴⁾	bar	10	10	10.3	10	10
Test pressure water side ⁵⁾	bar	15	15	15.5	15	15
Design temperature range ³⁾	°C	-10/+90	-10/+90	-10/+90	-10/+90	-10/+90

¹⁾ 45 bar design pressure for CDEW high pressure version

²⁾ 64 bar test pressure for CDEW high pressure version

³⁾ -10/+95°C design temperature for CFC, CRS, ACFL models

⁴⁾ 5 bar design pressure for CFC, CRS, ACFL models

⁵⁾ 8 bar test pressure for CFC, CRS, ACFL models

2 passes (Cooling tower water)

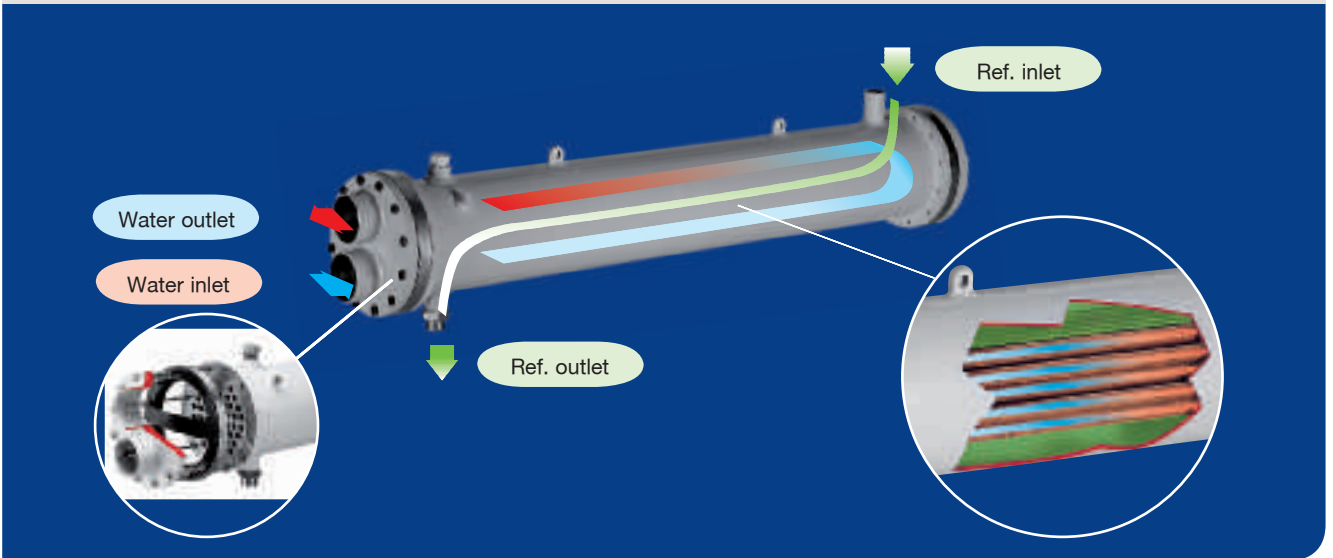

4 passes (City water)

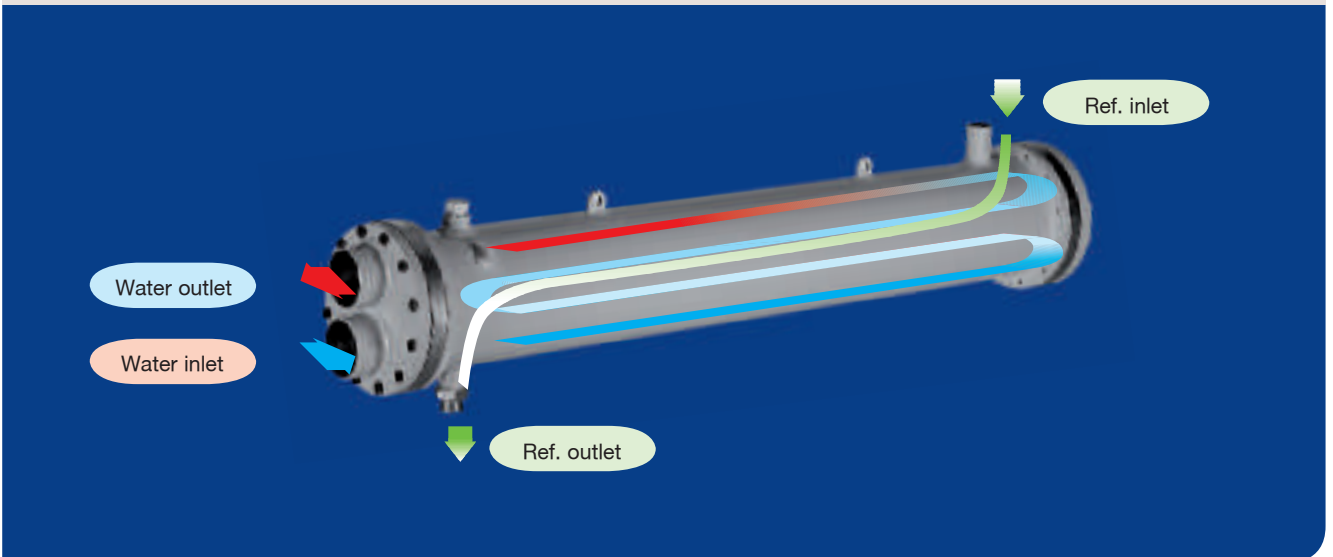

Sea water for a trouble-free condensation

2 condenser series are dedicated to sea water, for on board marine applications and for all the other installations where it is possible to use the sea as a natural source of cooling water.

Standard capacities range from 7 to 900 kW. Marine models are equipped with the following components:

- Shell: carbon steel
- Tube sheets: AISI 316 stainless steel
- Tubes: integrally finned Cu/Ni tubing
- Covers: AISI 316 stainless steel
- Gasket: thermopolymer compound
- Baffles: carbon steel

Marine units are provided with interchangeable anodes made of soft iron.



The nominal performances have been calculated on the basis of an FF equal to 0.000043 m²K/W (0.00005 h m²K/kcal).

v > 1.2 m/s	Normal city water	FF 0.000086 m ² K/W
	Treated tower water	
	Clear river water	
	Sea Water	

v > 1.2 m/s	City lime water	FF 0.000172 m ² K/W
	Normal tower water	
	Brine	

v > 1.2 m/s	Tower lime water	FF 0.000344 m ² K/W
	Muddy river water	



The ideal choice, when maintenance is needed

Shell and tube condensers are often used in combination with not perfectly clean water for heavy duty applications. It is an exciting challenge for a product designed in order to have a long working life. In these cases, periodical cleaning is required in order to

keep the heat exchanger's performances unchanged time by time.

Alfa Laval fresh and sea water condensers ensure easy opening for inspection, cleaning and maintenance purposes.

Fittings

CDEW condensers are equipped with square tube sheets ensuring a simple solution for the unit positioning. CPLUS and all the other series can be supplied with bolt-on supports (fig. A) or with supports welded directly to the shell body (fig. B).

Universal brackets to be easily mounting during the condenser installation can be supplied (fig. C). The type of required support should be specified when ordering.

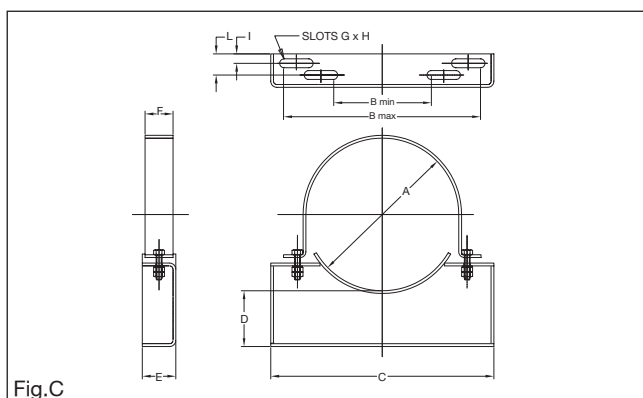
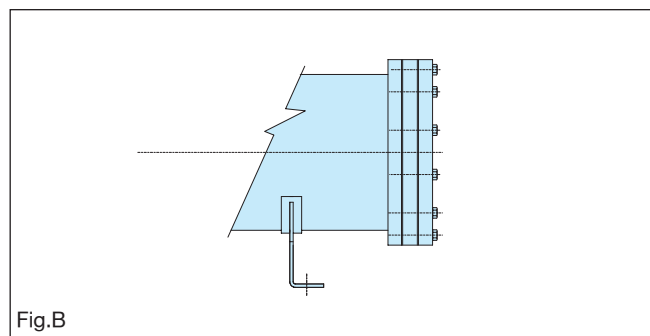
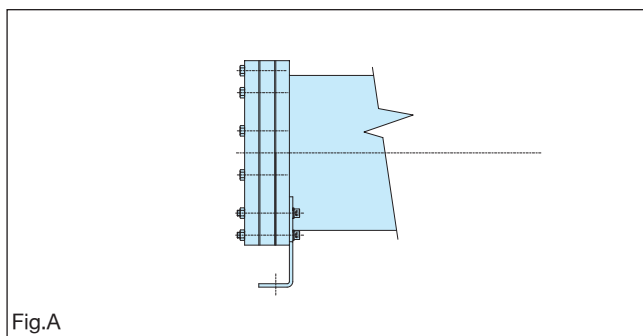

Universal Brackets Dimensions (mm)										
A	B	C	D	E	F	SLOTS		I	L	
140	82	178	220	60	50	40	12	60	25	-
168	112	208	250	60	50	40	12	60	25	-
194	46	238	280	60	50	40	12	60	15	32
219	82	276	320	80	50	40	12	60	15	32
273	176	352	400	100	60	50	16	60	17	38
324	108	372	420	100	60	50	16	60	17	38
406	216	468	520	120	80	60	18	60	20	54

Model	CDEW	60	80	100	120	135	165	190	215	240	260	300	360	400	450	470	520	550	610	680	760	840
Cooling tower water (2 passes)																						
R407C refrigerant	Qn (kW)	57	75	100	118	135	165	190	215	233	260	300	360	400	450	470	520	550	610	680	760	840
Tc, mean = 42°C	Wn (m³/h)	9.5	12.7	17.5	20.6	20.2	25.5	27.7	30.7	33.6	37.0	44.0	53.3	59.2	62.9	68.4	75.8	83.4	90.8	99.9	110.5	121.7
Ti = 29.4°C	Wm (m³/h)	12.3	16.4	22.5	26.6	27.6	35.8	38.9	43.0	43.0	51.1	61.4	73.6	81.8	86.9	94.1	104	114	122.7	135	151.4	167.7
FF = 0.000043 m² K/W	Dpn (bar)	0.33	0.33	0.33	0.33	0.33	0.33	0.33	0.33	0.38	0.38	0.38	0.38	0.38	0.38	0.38	0.38	0.38	0.38	0.38	0.38	0.38
City water (4 passes)																						
R407C refrigerant	Qn (kW)	60	81	109	130	146	182	203	225	250	280	330	396	452	487	510	566	635	670	740	828	924
Tc, mean = 35°C	Wn (m³/h)	3.4	4.5	6.1	7.2	7.5	9.3	10.2	11.3	12.1	14	16.8	20	22.1	23.8	25.6	28	31.5	33.8	37.1	41.6	46.2
Ti = 15°C	Wm (m³/h)	4.1	5.5	7.5	8.9	8.9	11.8	12.9	14.3	14.5	17.1	20.4	24.4	26.9	28.9	31.8	34.9	39	43	47.3	53	58.7
FF = 0.000043 m² K/W	Dpn (bar)	0.35	0.35	0.35	0.35	0.38	0.38	0.38	0.38	0.42	0.42	0.42	0.42	0.42	0.42	0.42	0.42	0.42	0.43	0.43	0.43	0.43

Model	CDEW-E	155	170	185	215	260	315	350	370	395	440	480	520	570	640	705
Cooling tower water (2 passes)																
R134a refrigerant	Qn (kW)	155	168	183	216	260	313	348	368	394	438	479	520	570	638	705
Tc = 37.5°C	Wn (m³/h)	24	26	28.6	34.1	41	49	54.5	58	62.6	69.5	76.2	82	90	101	112
Ti = 29.4°C	Wm (m³/h)	35.8	38.9	43	41.1	61.4	73.6	81.8	86.9	94.1	104	115	123	135	151	168
FF = 0.000043 m² K/W	Dpn (bar)	0.40	0.39	0.35	0.40	0.41	0.39	0.39	0.39	0.40	0.40	0.39	0.39	0.39	0.40	0.40
City water (4 passes)																
R134a refrigerant	Qn (kW)	175	190	210	250	300	360	400	428	460	512	560	600	660	740	825
Tc = 35°C	Wn (m³/h)	8.9	9.7	10.8	12.8	15.3	18.4	20.5	21.8	23.5	26.1	28.6	30.8	33.7	37.8	41.8
Ti = 15°C	Wm (m³/h)	14.9	16.2	17.9	21.3	25.6	30.7	34.1	36.2	39.2	43.5	47.7	51.1	56.3	63.1	69.9
FF = 0.000043 m² K/W	Dpn (bar)	0.47	0.46	0.41	0.44	0.43	0.44	0.44	0.43	0.44	0.46	0.43	0.45	0.45	0.45	0.44

Model	CPS	35	45	60	80	70	100	120	145	160	180	210	235	260	285	335	390	440	520
Cooling tower water (2 passes)																			
R22 refrigerant	Qn (kW)	33.5	46.2	59.1	81.8	68	96.1	120.7	144.3	162.4	182	208	236	260	285	336	388	438	522
Tc = 40.6°C	Wn (m³/h)	5.2	6.9	8.6	11.7	10.3	13.8	17.3	20.7	23.3	25.9	29.4	32.8	36.3	41.4	48.4	55.3	62.2	73.4
Ti = 29.4°C	Wm (m³/h)	6.2	8.3	10.4	14	12.4	16.6	20.7	24.9	28	31.1	35.2	39.4	43.5	49.7	58	66.3	74.6	88.1
FF = 0.000043 m² K/W	Dpn (bar)	0.44	0.44	0.44	0.44	0.37	0.37	0.37	0.37	0.37	0.37	0.37	0.37	0.37	0.37	0.37	0.37	0.37	0.37
City water (4 passes)																			
R22 refrigerant	Qn (kW)	37	50.1	63.1	87.1	69.9	98.6	121.5	146.7	165.6	182	207	234	260	288	339	389	442	523
Tc = 35°C	Wn (m³/h)	2	2.6	3.3	4.4	4	5.3	6.5	7.9	8.8	9.8	11.2	12.4	13.7	15.6	18.3	20.9	23.5	27.1
Ti = 15°C	Wm (m³/h)	2.6	3.5	4.3	5.8	5.2	6.9	8.6	10.4	11.7	13	14.7	16.4	18.1	20.7	24.2	27.6	31	36.7
FF = 0.000043 m² K/W	Dpn (bar)	0.5	0.5	0.5	0.5	0.42	0.42	0.42	0.42	0.42	0.41	0.41	0.41	0.41	0.41	0.41	0.41	0.41	0.42

Model	CFC	8	12	15	20	25	30	40	50	60
Cooling tower water (4 passes)										
R22 refrigerant	Qn (kW)	8.1	12.2	15.2	20.3	25.3	30.4	40.5	50.6	60.8
Tc = 40.6°C	Wn (m³/h)	1.5	2.2	2.2	3	3.7	4.5	6	7.5	9
Ti = 29.4°C	Wm (m³/h)	1.7	2.6	2.6	3.4	4.3	5.1	6.8	8.6	10.3
FF = 0.000043 m² K/W	Dpn (bar)	0.38	0.38	0.43	0.43	0.43	0.43	0.43	0.43	0.43
City water (8 passes)										
R22 refrigerant	Qn (kW)	9.1	13.6	15.7	21	26.2	31.5	42	52.5	63
Tc = 35°C	Wn (m³/h)	0.6	0.9	0.9	1.2	1.5	1.7	2.3	2.9	3.5
Ti = 15°C	Wm (m³/h)	0.8	1.3	1.3	1.7	2.1	2.6	3.4	4.3	5.1
FF = 0.000043 m² K/W	Dpn (bar)	0.48	0.48	0.54	0.54	0.54	0.54	0.54	0.54	0.54

Model	CRS	3	6	8	12	15	20	25
Cooling tower water (2 passes CRS 3-6 • 4 passes CRS 8-25)								
R22 refrigerant	Qn (kW)	3.2	6.5	8.1	12.2	15.2	20.3	25.3
Tc = 40.6°C	Wn (m³/h)	0.8	1.6	1.5	2.2	2.2	3	3.7
Ti = 29.4°C	Wm (m³/h)	0.9	1.8	1.7	2.6	2.6	3.4	4.3
FF = 0.000043 m² K/W	Dpn (bar)	0.22	0.22	0.38	0.38	0.43	0.43	0.43
City water (2 passes CRS 3-6 • 4 passes CRS 8-25)								
R22 refrigerant	Qn (kW)	3.8	7.7	9.1	13.6	15.7	21	26.2
Tc = 35°C	Wn (m³/h)	0.3	0.6	0.6	0.9	0.9	1.2	1.5
Ti = 15°C	Wm (m³/h)	0.5	0.9	0.8	1.3	1.3	1.7	2.1
FF = 0.000043 m² K/W	Dpn (bar)	0.28	0.28	0.48	0.48	0.54	0.54	0.54

Model	ACFL	450/360	450/414	450/468	450/522	450/576	750/648	750/738	750/828	750/900
Cooling tower water (2 passes)										
R22 refrigerant	Qn (kW)	360	414	468	522	576	648	738	828	900
Tc = 40.6°C	Wn (m³/h)	48.9	56.2	63.5	70.9	78.2	88	100	112	122
Ti = 29.4°C	Wm (m³/h)	55.5	63.9	72.2	80.5	88.9	99	113	127	138
FF = 0.000043 m² K/W	Dpn (bar)	0.33	0.33	0.33	0.33	0.33	0.33	0.33	0.33	0.33
City water (4 passes)										
R22 refrigerant	Qn (kW)	360	414	468	522	576	-	-	-	-
Tc = 35°C	Wn (m³/h)	18.9	21.7	24.5	27.4	30.2	-	-	-	-
Ti = 15°C	Wm (m³/h)	27.8	31.9	36.1	40.3	44.4	-	-	-	-
FF = 0.000043 m² K/W	Dpn (bar)	0.43	0.43	0.43	0.43	0.43	-	-	-	-

Model	CFC/M	8	12	15	20	25	30	40	50	60
Sea water	Passes	4	4	4	4	4	4	4	4	4
R22 refrigerant	Qn (kW)	7	10.6	13.2	17.8	22.2	26.8	35.6	44.7	53.6
Tc = 40.6°C	Wn (m³/h)	1.23	1.8	1.8	2.45	3.06	3.7	4.9	6.1	7.38
Ti = 29.4°C	Wm (m³/h)	1.4	2.1	2.1	2.86	3.57	4.3	5.7	7.12	8.61
FF = 0.000043 m² K/W	Dpn (bar)	0.26	0.25	0.29	0.3	0.3	0.3	0.3	0.3	0.3
Sea water	Passes	8	8	8	8	8	8	8	8	8
R22 refrigerant	Qn (kW)	9.1	13.6	15.7	21	26.2	31.5	42	52.5	63
Tc = 35°C	Wn (m³/h)	0.6	0.9	0.9	1.2	1.5	1.7	2.3	2.9	3.5
Ti = 15°C	Wm (m³/h)	0.8	1.3	1.3	1.7	2.1	2.6	3.4	4.3	5.1
FF = 0.000043 m² K/W	Dpn (bar)	0.48	0.48	0.54	0.54	0.54	0.54	0.54	0.54	0.54

Model	McDEW	15	25	34	48	50	67	90	105	123
Sea water	Passes	4	4	4	4	2	2	2	2	2
R407C refrigerant	Qn (kW)	15	24.5	34	48	51	67	90	106	123
Tc, mean = 43°C	Wn (m³/h)	2.4	3.6	4.8	6	7.2	9.59	13.19	15.59	16.19
Ti = 29.4°C	Wm (m³/h)	2.88	4.32	5.76	7.2	8.64	11.508	15.828	18.708	19.428
FF = 0.000043 m² K/W	Dpn (bar)	0.21	0.21	0.21	0.21	0.19	0.19	0.19	0.19	0.21
Sea water	Passes	8	8	8	8	4	4	4	4	4
R407C refrigerant	Qn (kW)	22.2	33.2	46.1	57.5	60	81	109	130	146
Tc, mean = 38°C	Wn (m³/h)	1.2	1.8	2.4	3	3.4	4.5	6.1	7.2	7.5
Ti = 15°C	Wm (m³/h)	1.44	2.16	2.88	3.6	4.08	5.4	7.32	8.64	9
FF = 0.000043 m² K/W	Dpn (bar)	0.4	0.4	0.41	0.4	0.34	0.34	0.34	0.34	0.34

Model	McDEW	153	175	200	205	238	275	330	370	410
Sea water	Passes	2	2	2	2	2	2	2	2	2
R407C refrigerant	Qn (kW)	153	175	198	206	238	276	331	367	413
Tc, mean = 43°C	Wn (m³/h)	20.99	22.78	25.18	25.18	29.98	35.98	43.17	47.97	50.96
Ti = 29.4°C	Wm (m³/h)	25.188	27.336	30.216	30.216	35.976	43.176	51.804	57.564	61.152
FF = 0.000043 m² K/W	Dpn (bar)	0.22	0.22	0.22	0.22	0.24	0.25	0.24	0.24	0.24
Sea water	Passes	4	4	4	4	4	4	4	4	4
R407C refrigerant	Qn (kW)	182	203	225	250	280	330	396	452	487
Tc, mean = 38°C	Wn (m³/h)	9.3	10.2	11.3	12.6	14	16.8	20	22.1	23.8
Ti = 15°C	Wm (m³/h)	11.16	12.24	13.56	15.12	16.8	20.16	24	26.52	28.56
FF = 0.000043 m² K/W	Dpn (bar)	0.34	0.34	0.4	0.4	0.4	0.4	0.4	0.4	0.4

Model	McDEW	430	480	505	555	620	700	770
Sea water	Passes	2	2	2	2	2	2	2
R407C refrigerant	Qn (kW)	431	477	505	555	619	696	772
Tc, mean = 43°C	Wn (m³/h)	55.16	61.16	67.15	71.95	79.15	88.74	98.33
Ti = 29.4°C	Wm (m³/h)	66.192	73.392	80.58	86.34	94.98	106.488	117.996
FF = 0.000043 m² K/W	Dpn (bar)	0.24	0.24	0.24	0.24	0.24	0.24	0.24
Sea water	Passes	4	4	4	4	4	4	4
R407C refrigerant	Qn (kW)	510	566	635	670	740	828	924
Tc, mean = 38°C	Wn (m³/h)	25.6	28	31.5	33.8	37.1	41.6	46.2
Ti = 15°C	Wm (m³/h)	30.72	33.6	37.8	40.56	44.52	49.92	55.44
FF = 0.000043 m² K/W	Dpn (bar)	0.4	0.4	0.41	0.41	0.41	0.41	0.41

Qn nominal condensation capacity
Wn nominal water flow rate

Wm maximum water flow rate
Tc condensing temperature

Ti water inlet temperature
FF fouling factor

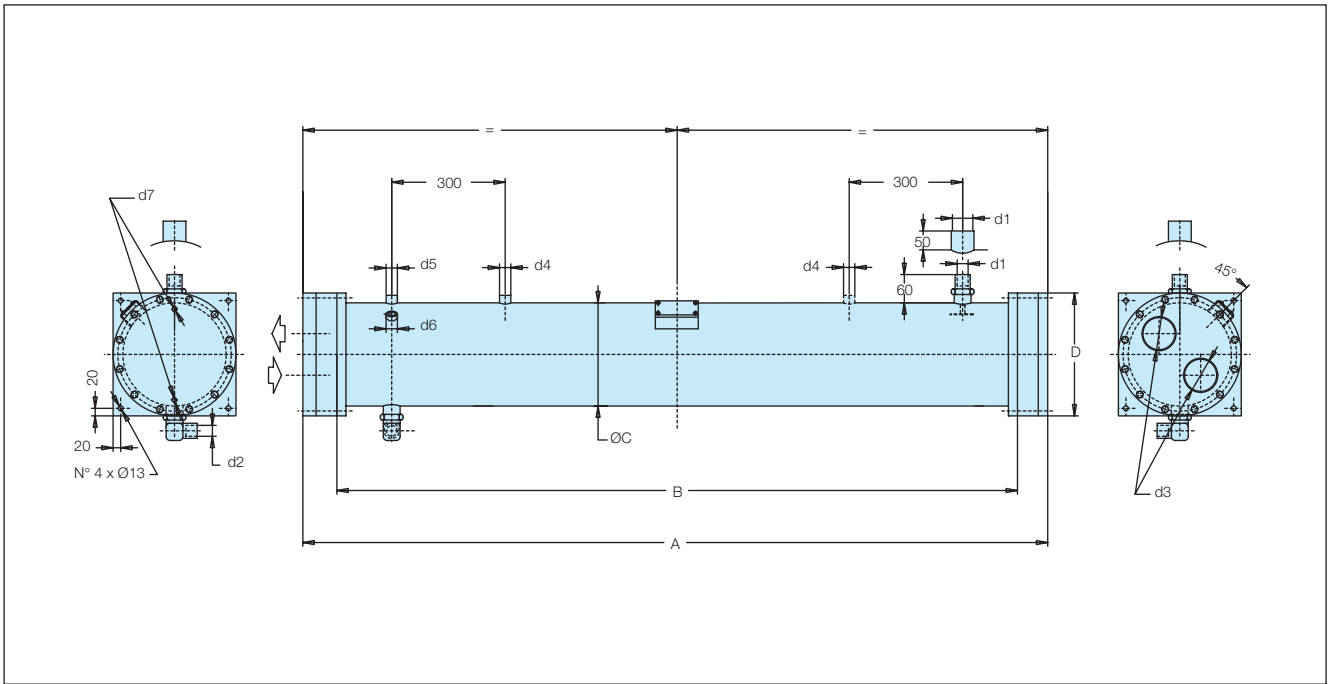

Model CDEW			60	80	100	120	135	165	190	215	240	260	300	360	400	450	470	520	550	610	680	760	840	
Dimensions	A	mm	1500				1700	1740			1940			1970					1980			1980		
	B	mm	1400				1600	1600			1800			1800					1800			1800		
	C	mm	168				194			273					324			406						
	D	mm	215				245			325					380			480						
	E	mm	30				35			55					65			-						
	F	mm	30				35			55					65			105						
	G	mm	43				55			75					90			70						
	H	mm	22				25			45					55			70						
	I	mm	43				55			75					90			80						
	L	mm	22				25			45					55			80						
	M	mm	170				200			225					250			260						
	M1	mm	180				210			235					260			270						
	N	mm	65				65			75					75			75						
	Connections	d1	mm	RC35				WA42			WA54					WA67			WA80					
d2		mm	RCL28				RCL35			WA42					WA54			WA54						
d3		in-G	T2				T21			T3			T4			T5								
d4		in-G	T11				T11			T2			T3			T4								
d5-A		in-NPT	1/2				3/4			1					1			1						
d5-B		in-NPT	-				-			-					1			1						
d5-C		in-NPT	-				-			-					-			1						
d6		in-NPT	1/4				1/5			1/4					1/4			1/4						
d7	in-G	1/4				1/4			1/4					1/4			1/4							
Volumes	Vr	dm³	22.3	20.8	19.4	18.1	20.1	24.9	23.7	21.9	24.9	70.6	66.1	57.0	53.1	50.6	90.5	86.1	81.7	152.1	146.0	137.8	129.6	
	Lres	dm³	3.8	3.8	3.4	3.1	0.9	7.1	6.7	2.8	3.1	10.0	10.0	8.4	8.4	3.4	5.2	5.2	4.7	14.8	14.8	14.8	14.8	
	VH ₂ O	dm³	4.8	5.9	7.3	8.2	10.1	13.3	14.2	15.4	17.1	24.7	27.7	31.2	33.9	35.7	41.0	44.1	47.5	52.4	57.7	64.7	71.7	
Weight	P	kg	58	61	65	68	85	105	108	111	121	195	203	215	222	227	293	304	313	441	452	467	482	

d1 refrigerant inlet
 d2 refrigerant outlet
 d7 for vent/for drain of water

d3 water connections
 d4 = d5 safety valve connection

Vr gas side volume
 VH₂O volume on the waterside

P net weight
 d6 service socket

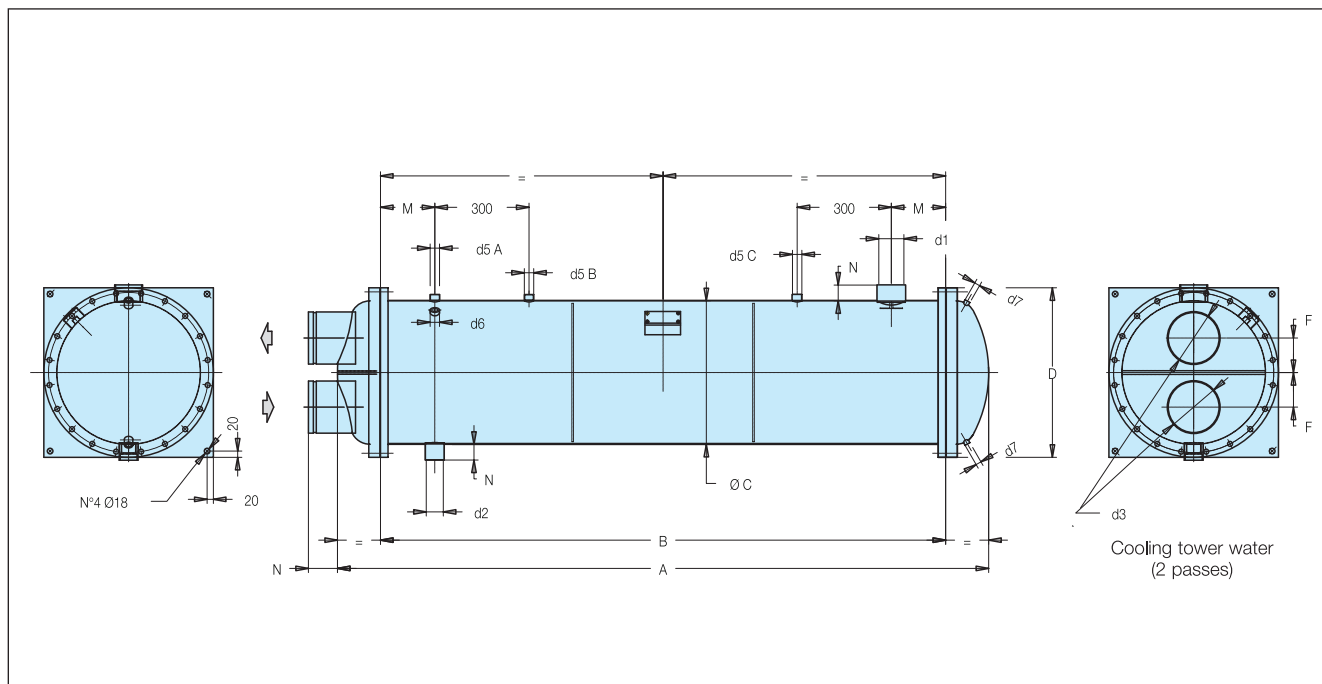

Model CDEW			900	940	1040	1100	1220	1360	1520	1680	
Dimensions	A	mm	2075			2105			2115		
	B	mm	1800			1800			1800		
	C	mm	457.2			508			558.8		
	D	mm	540			590			640		
	E	mm	-			-			-		
	F	mm	120			150			140		
	G	mm	-			-			-		
	H	mm	-			-			-		
	I	mm	-			-			-		
	L	mm	-			-			-		
	M	mm	-			-			-		
N	mm	93			88			82			
Connections	d1	mm	WA80			WA89			WA100		
	d2	mm	WA54			WA80			WA89		
	d3	in-G	J6			J6			J8		
	d4	in-G	-			-			-		
	d5-A	in-NPT	1			1			1		
	d5-B	in-NPT	1			1			1		
	d5-C	in-NPT	1			1			1		
	d6	in-NPT	1/4			1/4			1/4		
d7	in-G	1/4			1/4			1/4			
Volumes	Vr	dm ³	176.0	170.0	160.0	212.0	204.0	192.0	243.0	227.0	
	Lres	dm ³	17.0	17.0	17.0	21.0	21.0	21.0	15.0	15.0	
	VH ₂ O	dm ³	88.0	92.0	99.0	116.0	121.0	129.0	152.0	163.0	
Weight	P	kg	597	608	627	736	750	773	913	943	

d1 refrigerant inlet
 d2 refrigerant outlet
 d7 for vent / for drain of water

d3 water connections
 d4 = d5 safety valve connection

Vr gas side volume
 VH₂O volume on the water side

P net weight
 d6 service socket

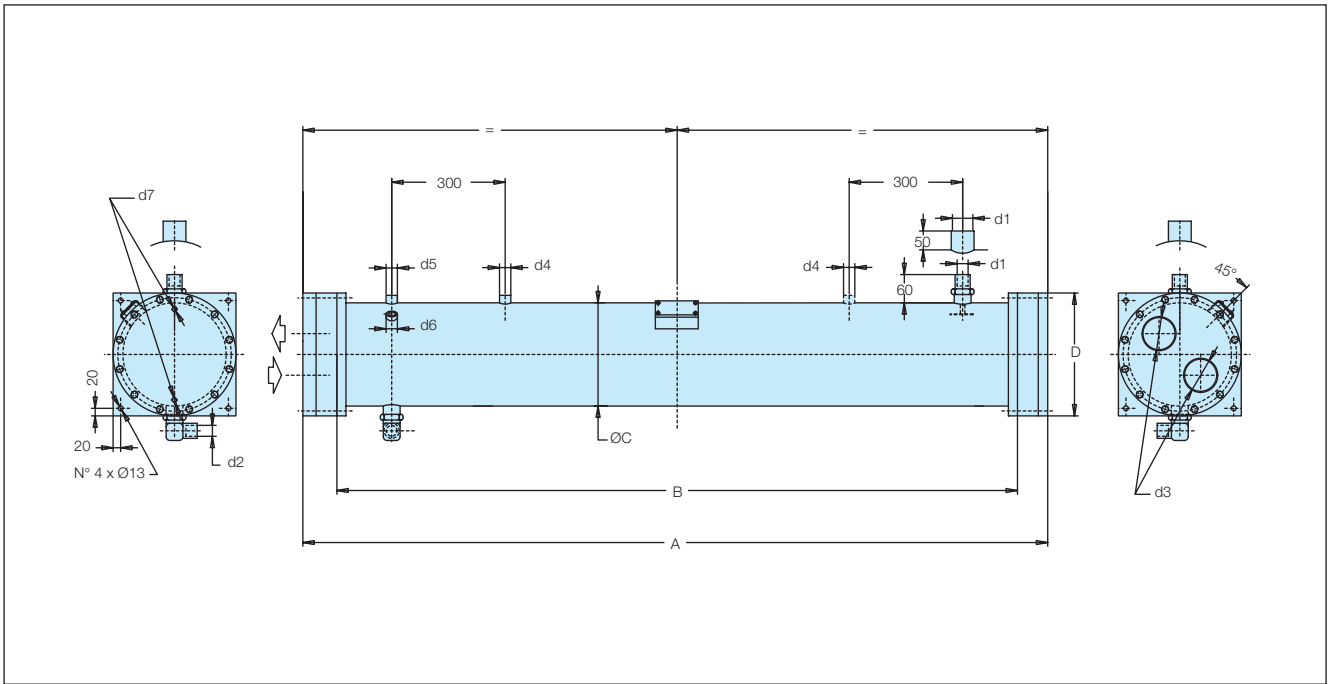

Model CDEW-E			155	170	185	215	260	315	350	370	395	440	480	520	570	640	705
Dimensions	A	mm	2540		2570			2570		2580			2580				
	B	mm	2400		2400			2400		2400			2400				
	C	mm	194		273			273		324			406				
	D	mm	245		325			325		380			480				
	E	mm	35		55			55		65			-				
	F	mm	35		55			55		65			105				
	G	mm	55		75			75		90			70				
	H	mm	25		45			45		55			70				
	I	mm	55		75			75		90			80				
	L	mm	25		45			45		55			80				
	M	mm	200		225			225		250			260				
	M1	mm	210		235			235		260			270				
	N	mm	65		75			75		75			75				
Connections	d1		WA42		WA54			WA67		WA67			WA80				
	d2		RCL35		WA42			WA54		WA54			WA54				
	d3	in-G	T21		T3			T3		T4			T5				
	d4	in-G	T11		T2			T2		T3			T4				
	d5-A	in-NPT	3/4		1			1		1			1				
	d5-B	in-NPT	-		-			-		1			1				
	d5-C	in-NPT	-		-			-		-			1				
	d6	in-NPT	1/4		1/4			1/4		1/4			1/4				
d7	in-G	1/4		1/4			1/4		1/4			1/4					
Volumes	Vr	dm³	37.4	35.6	33.1	93.9	87.9	75.8	70.6	67.3	120.4	114.5	108.7	202.3	194.2	183	172.4
	Lres	dm³	10.7	10.1	4.1	13.3	13.3	11.2	11.2	4.5	6.9	6.9	6.3	19.7	19.7	19.7	19.7
	VH ₂ O	dm³	20.0	21.3	20.5	32.9	36.9	41.5	45.1	47.5	54.5	58.7	63.2	69.7	76.7	86.1	95.4
Weight	W	kg	147	151	457	253	264	279	289	295	381	395	407	573	588	607	627

d1 refrigerant inlet
 d2 refrigerant outlet
 d7 for vent/for drain of water

d3 water connections
 d4 = d5 safety valve connection

Vr gas side volume
 VH₂O volume on the water side

P net weight
 d6 service socket

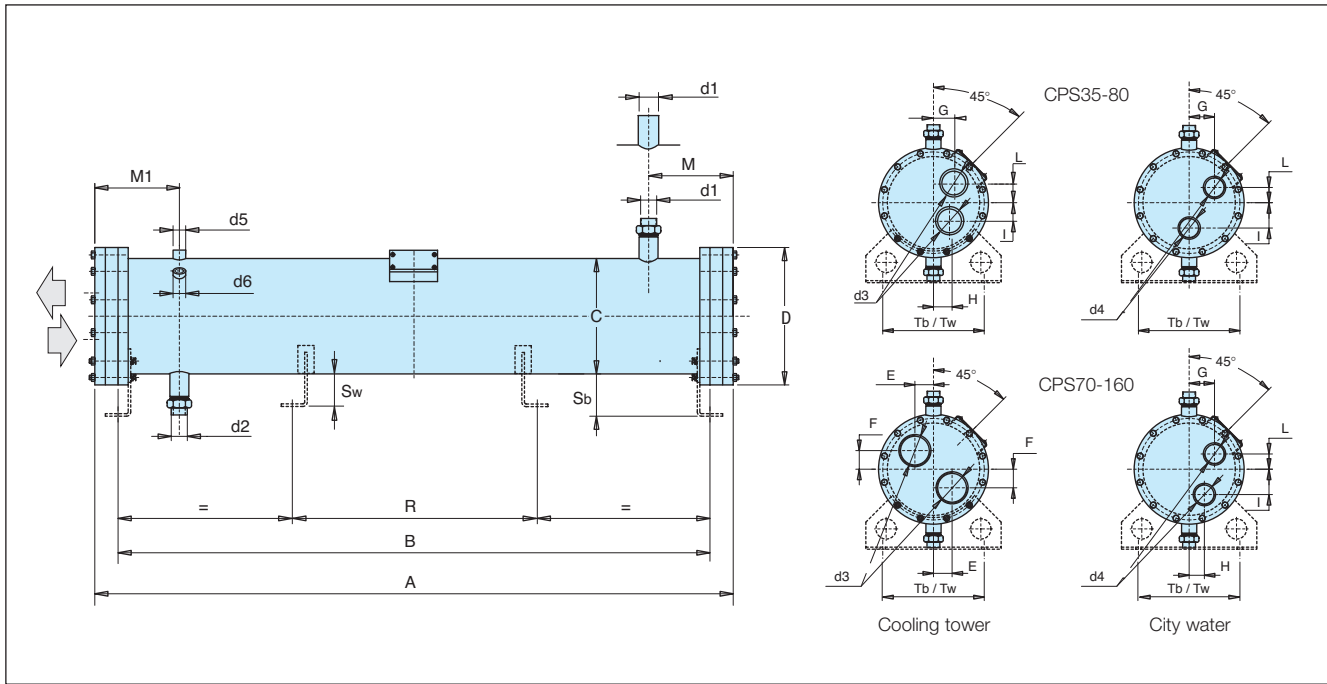

			CPS35	CPS45	CPS60	CPS80	CPS70	CPS100	CPS120	CPS145	CPS160	
Dimensions	A	mm	800	800	800	800	1500	1500	1500	1500	1500	
	B	mm	700	700	700	700	1400	1400	1400	1400	1400	
	C	mm	168	168	168	168	168	168	168	168	168	
	D	mm	215	215	215	215	215	215	215	215	215	
	E	mm	-	-	-	-	30	30	30	30	30	
	F	mm	-	-	-	-	30	30	30	30	30	
	G	mm	Tower 43 - City 45					43	43	43	43	43
	H	mm	Tower 22					22	22	22	22	22
	I	mm	Tower 43 - City 55					43	43	43	43	43
	L	mm	Tower 22 - City 32					22	22	22	22	22
	M	mm	160	160	160	160	170	170	170	170	170	
	M1	mm	170	170	170	170	180	180	180	180	180	
Supports	R	mm	350	350	350	350	900	900	900	900	900	
	Sb	mm	80	80	80	80	80	80	80	80	80	
	Sw	mm	60	60	60	60	60	60	60	60	60	
	Tb	mm	210	210	210	210	210	210	210	210	210	
	Tw	mm	160	160	160	160	160	160	160	160	160	
Connections	d1	-	RC28	RC28	RC28	RC28	RC35	RC35	RC35	RC35	WA42	
	d2	-	RB22	RB22	RB22	RB22	RC28	RC28	RC28	RC28	RC35	
	d3	-	T11	T11	T11	T11	T2	T2	T2	T2	T2	
	d4	-	T1	T1	T1	T1	T11	T11	T11	T11	T11	
	d5	in	3/8	3/8	3/8	3/8	1/2	1/2	1/2	1/2	1/2	
	d6	in	1/4	1/4	1/4	1/4	1/4	1/4	1/4	1/4	1/4	
Volumes	V _R	dm ³	11	10,3	9,6	8,5	22,7	21,3	19,9	16,5	17,5	
	V _{H2O}	dm ³	2,4	2,9	3,4	4,4	4	5	6,1	7,2	8	
Weight	P	Kg	43	45	47	49	60	63	66	69	72	

d1 refrigerant inlet
d2 refrigerant outlet

d3 = d4 water connections
d5 safety valve connection

V_R gas side volume
V_{H2O} volume on the water side

P net weight
d6 service socket

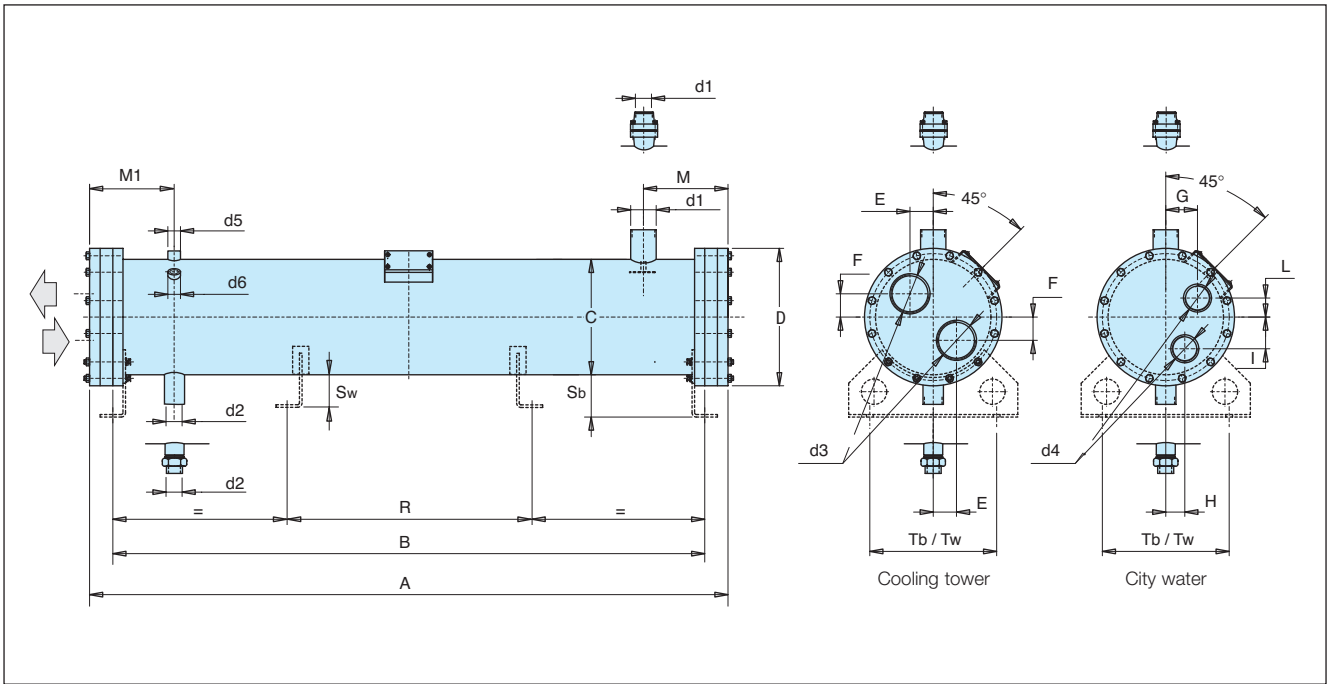

Model			CPS180	CPS210	CPS235	CPS260	CPS285	CPS335	CPS390	CPS440	CPS520
Dimensions	A Tower/City	mm	1540/1535	1540/1535	1540/1535	1540/1535	1570/1560	1570/1560	1570/1560	1570/1560	1570/1560
	B	mm	1400	1400	1400	1400	1400	1400	1400	1400	1400
	C	mm	194	194	194	194	273	273	273	273	273
	D	mm	245	245	245	245	325	325	325	325	325
	E	mm	35	35	35	35	55	55	55	55	55
	F	mm	35	35	35	35	55	55	55	55	55
	G	mm	55	55	55	55	75	75	75	75	75
	H	mm	25	25	25	25	45	45	45	45	45
	I	mm	55	55	55	55	75	75	75	75	75
	L	mm	25	25	25	25	45	45	45	45	45
	M	mm	200	200	200	200	225	225	225	225	225
M1	mm	210	210	210	210	235	235	235	235	235	
Supports	R	mm	900	900	900	900	900	900	900	900	900
	Sb	mm	80	80	80	80	100	100	100	100	100
	Sw	mm	60	60	60	60	100	100	100	100	100
	Tb	mm	210	210	210	210	300	300	300	300	300
Tw	mm	160	160	160	160	300	300	300	300	300	
Connections	d1	-	WA42	WA42	WA54	WA54	WA54	WA54	WA54	WA54	WA54
	d2	-	RC35	RC35	RC35	RC35	WA42	WA42	WA42	WA42	WA42
	d3	-	T21	T21	T21	T21	T3	T3	T3	T3	T3
	d4	-	T11	T11	T11	T11	T2	T2	T2	T2	T2
	d5	in	3/4	3/4	3/4	3/4	1	1	1	1	1
	d6	in	1/4	1/4	1/4	1/4	1/4	1/4	1/4	1/4	1/4
Volumes	VR	dm ³	24,8	23,4	22	20,6	54,7	51,9	49,1	46,3	41,8
	VH ₂ O	dm ³	9,4	10,5	11,6	12,6	16,2	18,3	20,5	22,6	26,1
Weight	P	Kg	91	94	97	100	164	170	176	182	195

d1 refrigerant inlet
d2 refrigerant outlet

d3 = d4 water connections
d5 safety valve connection

VR gas side volume
VH₂O volume on the water side

P net weight
d6 service socket

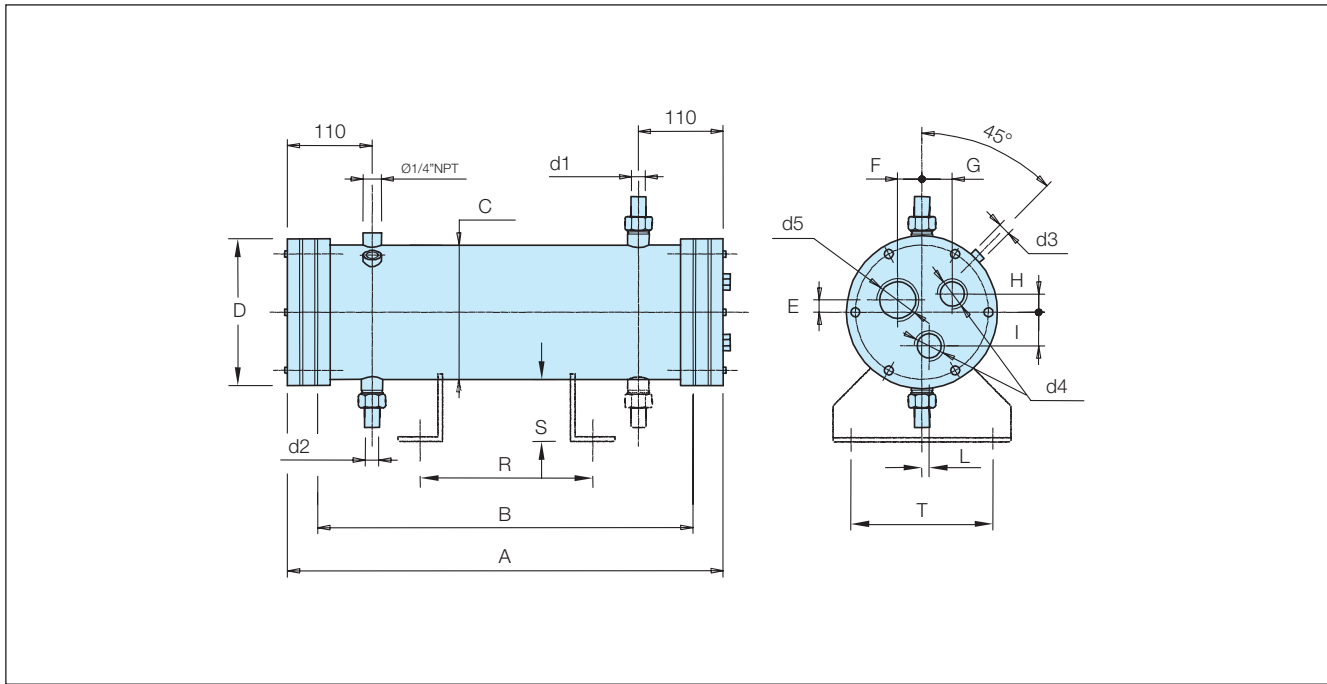

			CFC 8	CFC 12	CFC 15	CFC 20	CFC 25	CFC 30	CFC 40	CFC 50	CFC 60
Dimensions	A	mm	660	660	860	860	870	870	870	870	870
	B	mm	600	600	800	800	800	800	800	800	800
	C	mm	114	114	114	114	168	168	168	193	193
	D	mm	120	120	120	120	170	170	170	195	195
	E	mm	13	13	13	13	19	19	19	20	20
	F	mm	28	28	28	28	44	44	44	50	50
	G	mm	23	23	23	23	44	44	44	50	50
	H	mm	28	28	28	28	32	32	32	35	35
	I	mm	28	28	28	28	52	52	52	58	58
	L	mm	23	23	23	23	0	0	0	0	0
	R	mm	300	300	500	500	500	500	500	500	500
	S	mm	60	60	60	60	60	60	60	60	60
	T	mm	160	160	160	160	160	160	160	160	160
	d1	RT	1"	1"	1"	1"	1 1/4"	1 1/4"	1 1/4"	1 1/4"	1 1/4"
	d2	RT	1"	1"	1"	1"	1"	1"	1"	1 1/4"	1 1/4"
	d3	NPT	3/8"	3/8"	3/8"	3/8"	3/8"	3/8"	3/8"	3/8"	3/8"
	d4	FPT	1/2"	1/2"	1/2"	1/2"	3/4"	3/4"	3/4"	1 1/4"	1 1/4"
	d5	FPT	3/4"	3/4"	3/4"	3/4"	1 1/4"	1 1/4"	1 1/4"	1 1/2"	1 1/2"
	VR	dm ³	4,3	3,9	5,3	4,8	12,5	12	11	14,9	12,5
	VH ₂ O	dm ³	0,75	1,0	1,2	1,5	2,1	2,4	3,0	3,6	4,2
P	kg	13,5	14,5	17	18,5	33	34,5	37,5	49,5	52,5	
ES	m ²	0,82	1,23	1,67	2,23	2,79	3,35	4,5	5,6	6,7	

d1 refrigerant inlet
d2 refrigerant outlet

d3 safety valve connection
d4 = d5 water connections

VR gas side volume
VH₂O fouling factor

P net weight
ES exchange surface

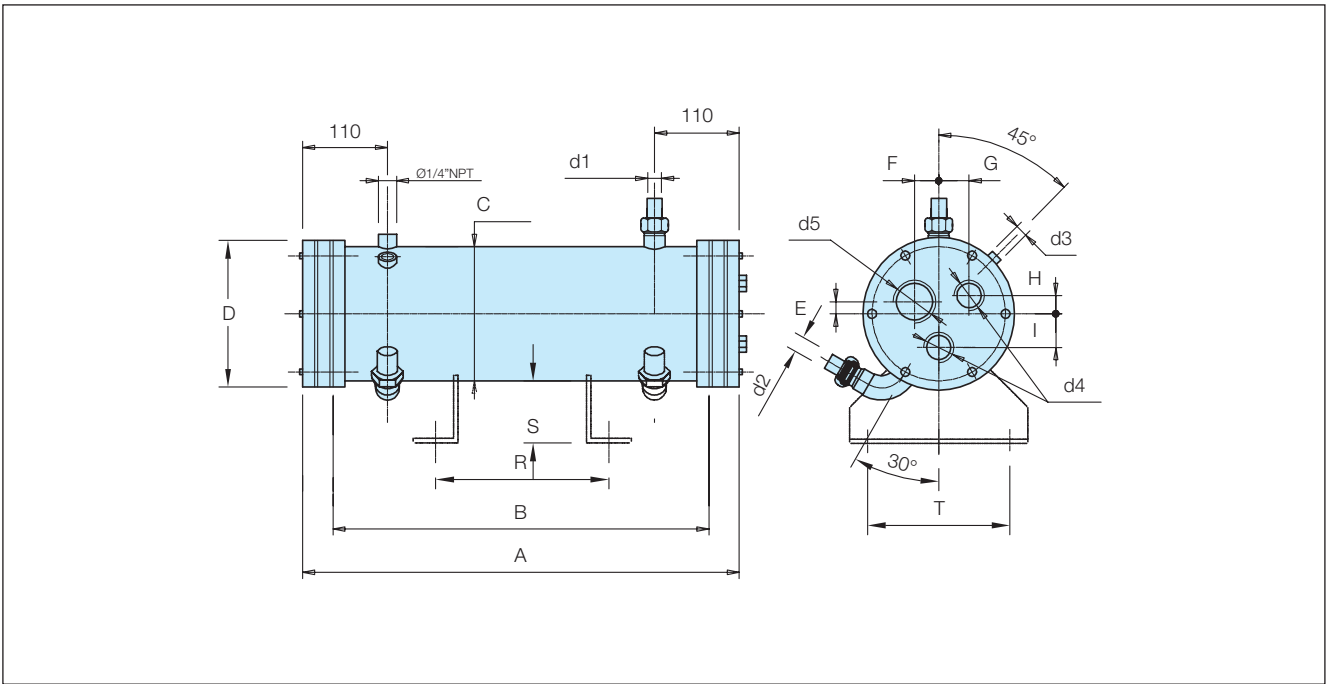

		CRS 3	CRS 6	CRS 8	CRS 12	CRS 15	CRS 20	CRS 25	
Dimensions	A	mm	670	670	670	870	870	870	
	B	mm	600	600	600	800	800	800	
	C	mm	168	168	168	168	193	193	
	D	mm	170	170	170	170	195	195	
	E	mm	19	19	19	19	20	20	
	F	mm	41	41	44	44	50	50	
	G	mm	44	44	44	44	50	50	
	H	mm	27	27	32	32	35	35	
	I	mm	52	52	52	52	58	58	
	R	mm	300	300	300	300	500	500	
	S	mm	60	60	60	60	60	60	
	T	mm	160	160	160	160	160	160	
	d1	RT	1"	1"	1"	1"	1 1/4"	1 1/4"	1 1/4"
	d2	RT	1"	1"	1"	1"	1"	1"	1"
	d3	NPT	3/8"	3/8"	3/8"	3/8"	3/8"	3/8"	3/8"
	d4	FPT	3/4"	3/4"	3/4"	3/4"	1 1/4"	1 1/4"	1 1/4"
	d5	FPT	1"	1"	1"	1"	1 1/2"	1 1/2"	1 1/2"
VR	dm ³	10,8	10,4	10,4	10	18,5	18	17,5	
VH ₂ O	dm ³	0,8	1,0	1,2	1,4	1,8	2,1	2,4	
P	kg	23	24	24	25	39	40,5	42	
ES	m ²	0,41	0,82	0,82	1,23	1,67	2,23	2,79	

d1 refrigerant inlet
d2 refrigerant outlet

d3 safety valve connection
d4 = d5 water connections

VR gas side volume
VH₂O fouling factor

P net weight
ES exchange surface

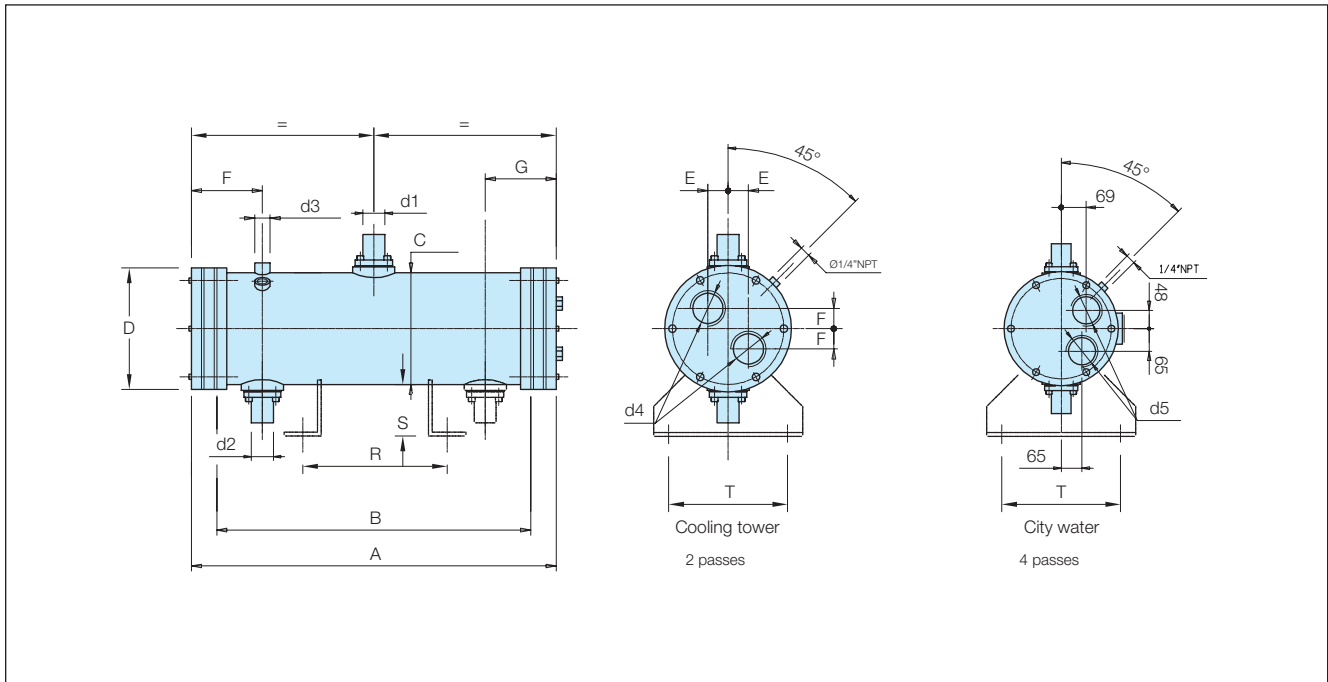

			ACFL 450/360	ACFL 450/414	ACFL 450/468	ACFL 450/522	ACFL 450/576	ACFL 750/648	ACFL 750/738	ACFL 750/828	ACFL 750/900	
Dimensions	A	mm	2500	2500	2500	2500	2500	2540	2540	2540	2540	
	B	mm	2400	2400	2400	2400	2400	2400	2400	2400	2400	
	C	mm	324	324	324	324	324	406	406	406	406	
	D	mm	325	325	325	325	325	410	410	410	410	
	E	mm	56	56	56	56	56	70	70	70	70	
	F	mm	205	205	205	205	205	225	225	225	225	
	G	mm	200	200	200	200	200	220	220	220	220	
	R	mm	1700	1700	1700	1700	1700	1700	1700	1700	1700	
	S	mm	100	100	100	100	100	120	120	120	120	
	T	mm	300	300	300	300	300	400	400	400	400	
	d1	FL		100x100	100x100	100x100	100x100	100x100	145	145	145	145
	d2	FL		70x70	70x70	70x70	70x70	70x70	90x90	90x90	90x90	90x90
	d3	NPT		2x1"	2x1"	2x1"	2x1"	3x1"	3x1"	3x1"	3x1"	3x1"
	d4	FPT		4"	4"	4"	4"	4"	5"	5"	5"	5"
	d5	FPT		3"	3"	3"	3"	3"	-	-	-	-
	VR	dm ³		133,8	126,9	120	113,1	106,2	205	193,7	182,5	173,8
	VH ₂ O	dm ³		33,4	37,8	42,2	46,7	51,1	62,8	70,2	77,6	83,7
P	kg		295	309,5	324	338,5	353	494	518	541	559	
ES	m ²		42	48,3	54,5	60,8	67,1	75,5	86	96,5	104,9	

d1 refrigerant inlet
d2 refrigerant outlet

d3 safety valve connection
d4 = d5 water connections

VR gas side volume
VH₂O fouling factor

P net weight
ES exchange surface

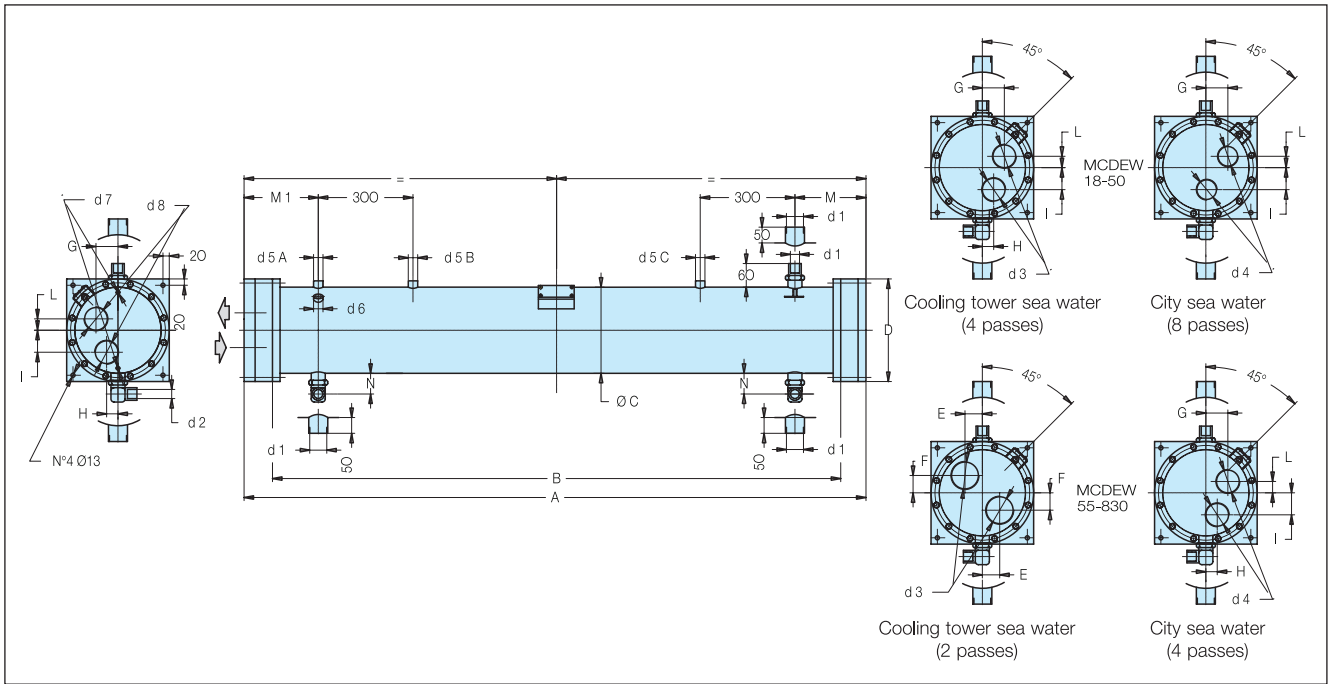

Model McDEW		15	25	34	48	50	67	90	105	123	153	175	200	205	238	275	330	370	410	430	480	505	555	620	700	770	
Dimensions	A	mm	800				1500				1700	1740			1940	1970						1980		1980			
	B	mm	700				1400				1600	1600			1800	1800						1800		1800			
	C	mm	168				168				194			273						324		406					
	D	mm	215				215				245			325						380		480					
	E	mm	-				30				35			55						65		-					
	F	mm	-				30				35			55						65		105					
	G	mm	Tower 43-City 55				43				55			75						90		70					
	H	mm	Tower 22				22				25			45						55		70					
	I	mm	Tower 43-City 55				43				55			75						90		80					
	L	mm	Tower 43-City 32				22				25			45						55		80					
	M	mm	160				170				200			225						250		260					
	M1	mm	170				180				210			235						260		270					
	N	mm	65				65				65			75						75		75					
Connections	d1	mm	RC28				RC35				WA42			WA54						WA67		WA80					
	d2	mm	RBL22				RCL28				RCL35			WA42						WA54		WA54					
	d3	in-G	T11				T2				T21			T3						T4		T5					
	d4	in-G	T1				T11				T11			T2						T3		T4					
	d5-A	in-NPT	3/8				1/2				3/4			1						1		1					
	d5-B	in-NPT	-				-				-			-						1		1					
	d5-C	in-NPT	-				-				-			-						-		1					
	d6	in-NPT	1/4				1/4				1/4			1/4						1/4		1/4					
Volumes	Vr	dm ³	11.7	11.0	10.3	8.7	22.3	20.8	19.4	18.1	20.1	24.9	23.7	21.9	24.9	70.6	66.1	57.0	53.1	50.6	90.5	86.1	81.7	152.1	146.0	137.8	129.6
	Lres	dm ³	1.9	1.9	1.9	1.9	3.8	3.8	3.4	3.1	0.9	7.1	6.7	2.8	3.1	10.0	10.0	8.4	8.4	3.4	5.2	5.2	4.7	14.8	14.8	14.8	14.8
Weight	VH ₂ O	dm ³	1.9	2.4	2.9	3.7	4.8	5.9	7.3	8.2	10.1	13.3	14.2	15.4	17.1	24.7	27.7	31.2	33.9	35.7	41.0	44.1	47.5	52.4	57.7	64.7	71.7
	P	kg	41	43	45	47	58	61	65	68	85	105	108	111	121	195	203	215	222	227	293	304	313	441	452	467	482

d1 refrigerant inlet
 d2 refrigerant outlet
 d7 for vent/for drain of water

d3 = d4 = d8 water connections
 d5 safety valve connection

Vr gas side volume
 VH₂O volume on the water side

P net weight
 d6 service socket

Refrigerant connections

Refrigerant inlet and outlet can be equipped with Rotalock brazing (ODS), welding (OD) or flanged (F) connections. All data concerning the different connections available are indicated in the following table.

Sea water series have two refrigerant outlet connections.

Rotalock connection (R)

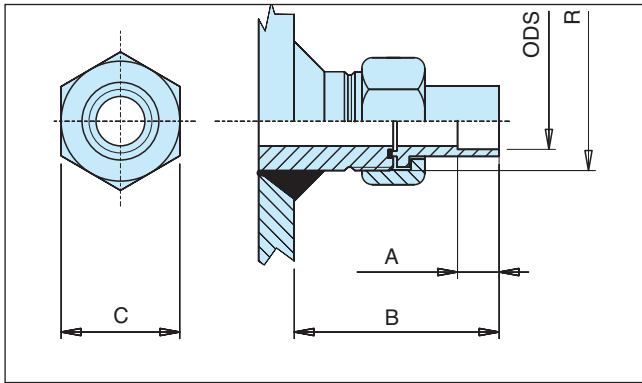

Rotalock (CDEW / CDEW-E / CPS / McDEW)							
Type	A	B	C	RT	Name	ODS	ID
	[mm]	[mm]	[mm]			[mm]	[mm]
B	20	80	36	1 1/4" - 12UNF	RB22	22	22,5
	20	80	50	1 3/4" - 12UNF	RC28	28	28,3
C	20	80	50	1 3/4" - 12UNF	RC35	35	35,3

Rotalock (CFC • CRS • ACFL)				
B	C	RT	Name	ODS
[mm]	[mm]			[mm]
63	30	1" - 14UNF	RB16	16
63	36	1 1/4" - 12UNF	RC22	22
63	50	1 3/4" - 12UNF	RC38	35

Welding connection (W)

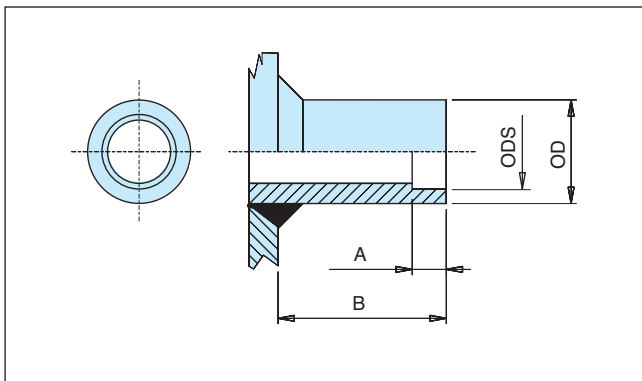

Welding (CDEW / CDEW-E / CPS / McDEW)						
Type	A	B	Name	ODS	ID	OD
	[mm]	[mm]		[mm]	[mm]	[mm]
A	20	70	WA42	42	42,4	48,3
	20	70	WA54	54	54,4	60,3
	20	70	WA80	80	80,6	88,9

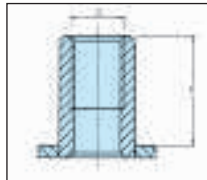

NPT (CFC • CRS • CFL • ACFC • ACFL)				
D	1/4"	3/8"	1/2"	1"
d (mm)	20	24	30	40
H (mm)	22	22	25	25

Flange connection (F)

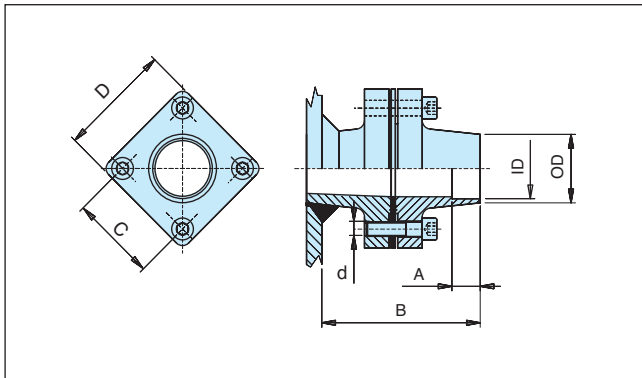

Flange (CDEW / CDEW-E / CPS / McDEW)									
Type	A	B	C	D	d	Name	ODS	ID	OD
	[mm]	[mm]	[mm]	[mm]			[mm]	[mm]	[mm]
A	20	110	55	75	M10	FA35	35	35,3	-
	20	110	55	75	M10	FA42	42	42,4	-
	20	110	55	75	M10	FA54	54	54,4	-
B	20	130	70	90	M10	FB54	54	54,4	-
	20	130	70	90	M10	FB67	67	67,4	76
C	20	130	90	110	M12	FC67	67	67,4	76
	20	130	90	110	M12	FC80	80	80,6	88,9

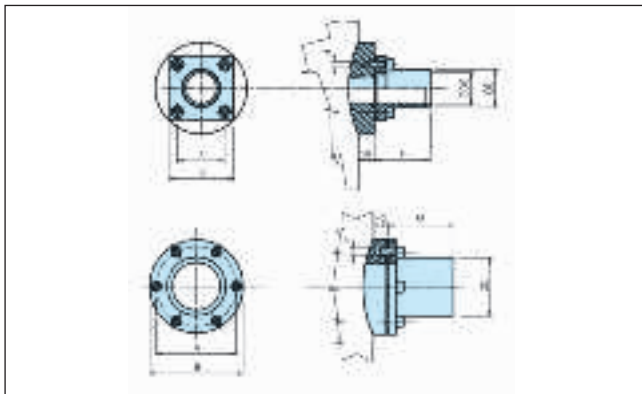

Flange (CFC • CRS • ACFL)						
FL	60X60	70X70	90X90	100X100	145	160
A (mm)	60	70	90	100	Ø145	Ø160
B (mm)	80	90	110	125	Ø170	Ø190
ODS (mm)	42	54			-	-
OD (mm)			76,1	88,9	101,6	114,3
H (mm)	70	85	100	125		
d	M10	M10	M12	M12	M12	M16

Special connections (CPLUS)

CPS	160	180	210	260	285	335	390	440	520
Refrigerant inlet (d1)	Type A				Type B				
Refrigerant outlet (d2)	-	-	-	-	Type A				

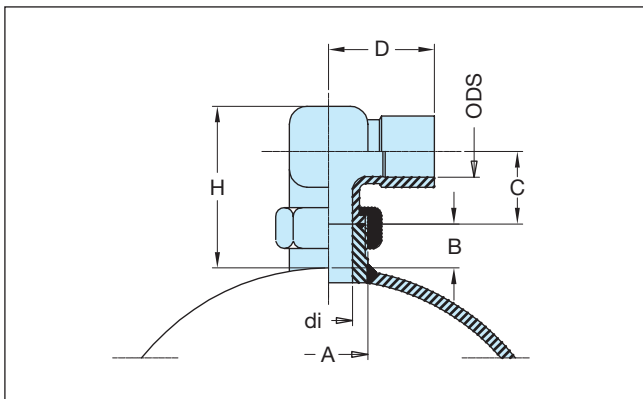

Rotalock		CDEW /CDEW-E / McDEW)		Type B	Type C	
Rotalock type	Name			RB 22	RB 28	RB 35
A	UNF			1 1/4"	1 3/4"	
B	mm			28	27	27
C	mm			29	38	
D	mm			44	47	52
di	mm			19	31	
H	mm			71	83	
ODS	mm			22	28	35

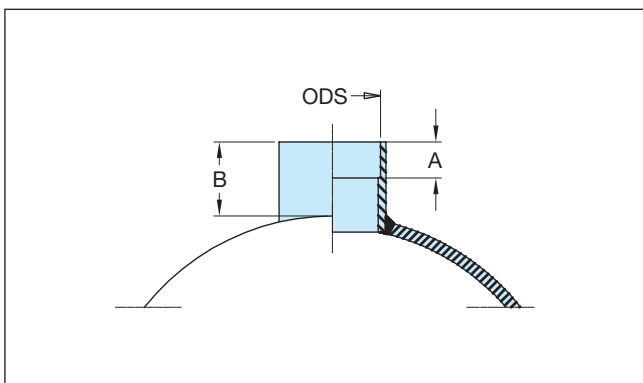

Welding connections		CDEW /CDEW-E / McDEW)		Type A	Type B	Type C	Type D
Welding type	Name			WA 42	WA 54	WA 67	WA 80
A	mm			20	20	25	25
B	mm			50	50	50	50
ODS	mm			42	54	67	80
OD	mm			48.3	60.3	76.1	88.9

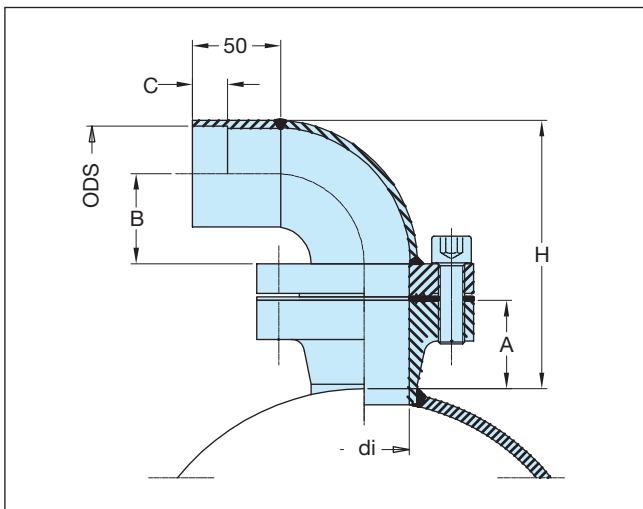

Special flange connections		CDEW /CDEW-E / McDEW)		Type A	Type B	Type C		
Flange type	Name			FA 35	FA 42	FB 54	FC 67	FC 80
A	mm			45	45	45		
B	mm			32	38	51	63	76
C	mm			20	20	25		
di	mm			39	51	75		
H	mm			119	128	152	172	191
ODS	mm			35	42	54	67	80
OD	mm			42.4	48.3	60.3	76.1	88.9

CDEW, CDEW-E, McDEW, CPS

Water inlet and outlet connections on the condenser are ISO 228/1-G female threaded connections. As an optional for models CPS285-520, the connection can be provided via a

flexible joint using a clamp and a gasket in EPDM. A stub-end is supplied to which the water pipework can be welded.

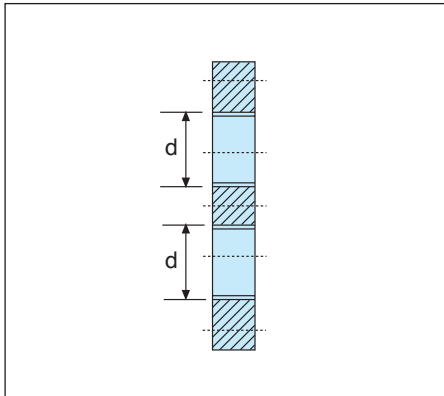

Threaded connections (T)				
Model	TOWER		CITY	
	Name	d (in)	Name	d (in)
CPS 35-80 / McDEW 15-48	T11	1 1/2	T1	1
CPS 70-160/CDEW 60-135/McDEW 50-123	T2	2	T11	1 1/2
CPS 180-260/CDEW 165-240/CDEW-E 155-185/McDEW 153-205	T21	2 1/2	T11	1 1/2
CPS 285-520/CDEW-E 260-450/CDEW-E 215-370/McDEW 238-410	T3	3	T2	2
CDEW 470-550/CDEW-E 395-480/McDEW 430-505	T4	4	T3	3
CDEW 610-840/CDEW-E 520-705/McDEW 555-770	T5	5	T4	4

Flexible joint with connection pipe (J)

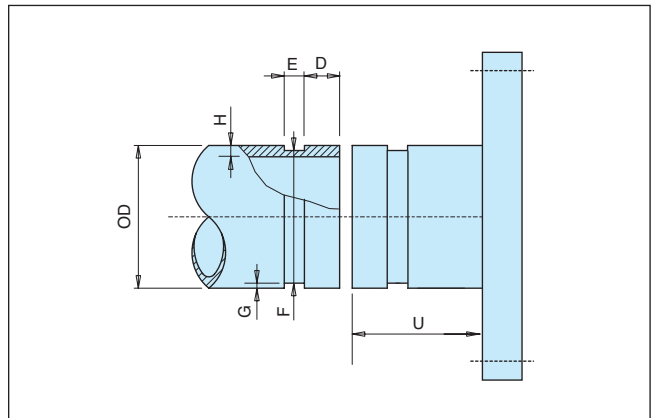
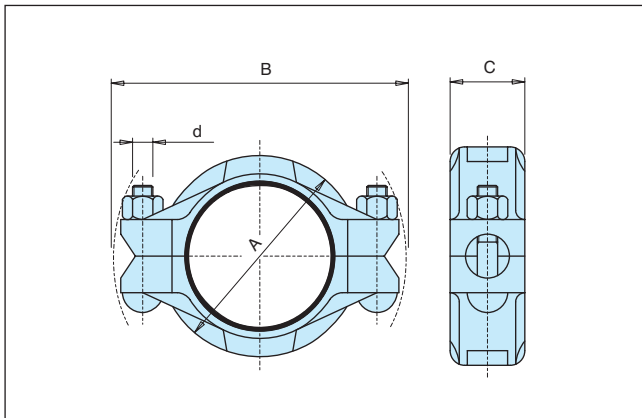

Model	FLEXIBLE JOINT						CONNECTION PIPE								
	A mm	B mm	C mm	d	Name	OD mm	DN	OD mm	DN	D mm	E mm	F mm	G mm	H mm	U mm
CPS 285-520	117.5	181	44.5	M12	JP	88,9	80 (3")	88.9	80 (3")	15.9	7.9	84.9	2	4,8	73

CFC • CRS • ACFL

Condensers series CFC, CRS, series up to model 150/183 and ACFL series up to model 180/207 can have two types of connections: city water (scheme A) and tower water (scheme B). Condensers series ACFC starting with model 240/183 and ACFL series starting with model 300/207 are provided with

tower water connection (scheme C, 2 passes) or on request with city water connection (scheme D, 4 passes). Starting from ACFL 750/648 only tower connection is available (scheme C or scheme E, 2 passes). Marine condensers are not available with A or B connections.

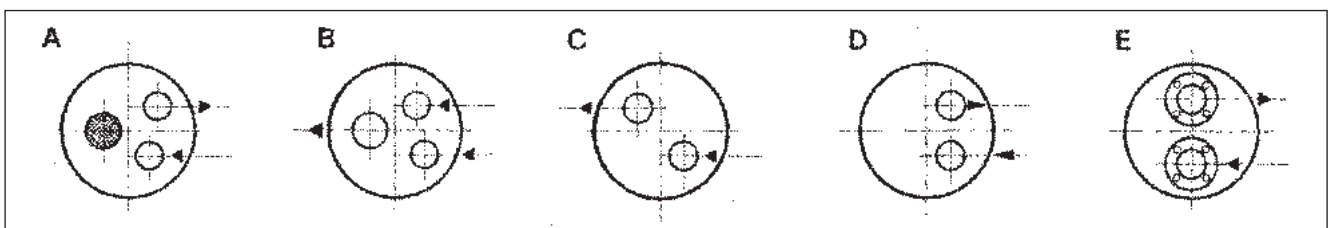

CDEW, CDEW-E, CPS

It is possible to convert the standard female threaded connections to a flexible joint solution with or without temperature sockets.

Different adaptor kits can be supplied.

Water inlet with temperature socket

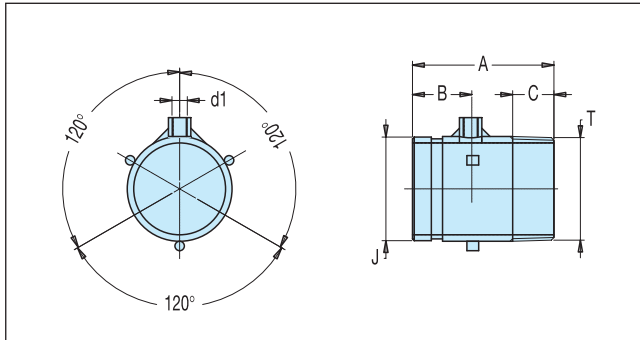

Type	CONNECTION PIPE					
	A mm	B mm	C mm	T in-G	J in	d1 in-G
T21-14 - J21	170	100	30	2-1/2	2-1/2	1/4
T3-14 - J3	120	50	35	3	3	1/4
T4-14 - J4	170	100	40	4	4	1/4
T5-14 - J5	170	100	45	5	5	1/4

Water outlet

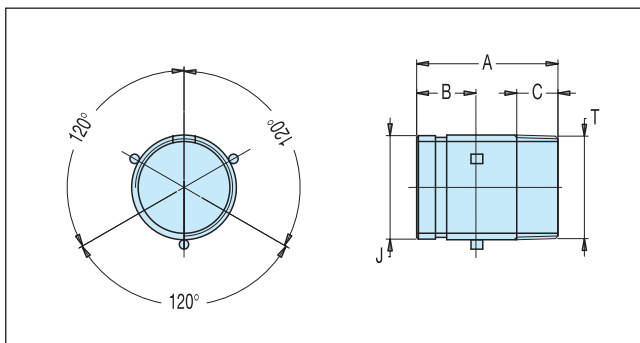

Type	CONNECTION PIPE					
	A mm	B mm	C mm	T in-G	J in	DN x sp mm
T21 - J21	100	50	30	2-1/2	2-1/2	76.1x5
T3 - J3	100	50	35	3	3	88.9x5.49
T4 - J4	100	50	40	4	4	114.3x3.2
T5 - J5	100	50	45	5	5	139.7x4

Kit

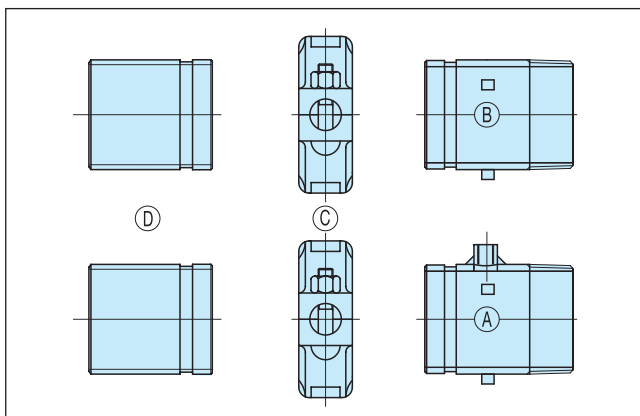

Type	COMPONENTS			
	Adapter in A) Nbr	Adapter out B) Nbr	Flex. joint C) Nbr	Count. pipe D) Nbr
KIT T21 - J21	1	1	2	2
KIT T3 - J3	1	1	2	2
KIT T4 - J4	1	1	2	2
KIT T5 - J5	1	1	2	2