



# The Standard Duty Pump

## SolidC Pump

### Applications

The SolidC pump is designed for standard duty applications, like pumping CIP (Cleaning In Place) solutions, utilities, water (processing, heating, cooling), washing machines, simple transport duty within working range. SolidC is suited for use in the food, dairy, beverage, personal care, pharmaceutical, light chemical and water industries.

### Standard design

The SolidC pump consists of a standard motor, stub shaft, mechanical compression coupling, adaptor, back plate, impeller, pump casing and shaft seal.

The SolidC pump is designed for CIP with emphasis on large internal roundings and cleanable seals.

SolidC has a stainless steel shroud for protection of the motor, and the complete unit is supported on four adjustable legs.

### Shaft seals

The SolidC pump is equipped with either an external single or a flushed shaft seal. Both have stationary seal rings in acid-resistant steel AISI 329 with sealing surface in silicon carbide and rotating seal rings in carbon. The secondary seal of the flushed seal is a long lasting lip seal.

### Materials

Product wetted steel parts: . . . . . Acid-resistant steel 1.4404 (316L).

Other steel parts: . . . . . Stainless steel 1.4301 (304).

Finish: . . . . . Blasted (standard)  
3A polishing (Ra 0.8).

Product wetted seals: . . . . . EPDM rubber (acc. to FDA).

### Technical data

Max. inlet pressure: . . . . . 400 kPa (4 bar).

Temperature range: . . . . . -10°C to +120°C (EPDM).

### Flushed shaft seal (FSS):

Water pressure inlet: . . . . . max. 100 kpa (1 bar).

Water consumption: . . . . . 0.25 -0.5 l/min.

### Connections for FSS:

R 1/8" (BSP) external thread.

### Motor

Foot-flanged motor according to the IEC metric standard (EFF II), 2 poles = 3000/3600 rpm. at 50/60 Hz, IP 55 (with drain hole with labyrinth plug), insulation class F.



SolidC pump.

### Voltage and frequency

3 ~, 50 Hz, 220-240V Δ/380-420VY	≤ 4 kW
3 ~, 60 Hz, 250-280V Δ/440-480VY	≤ 4.6 kW
3 ~, 50 Hz, 380-420V Δ/660-690VY	≥ 5.5 kW
3 ~, 60 Hz, 440-480V Δ	≥ 6.4 kW

### Motor sizes

**50 Hz:** 1.1, 1.5, 2.2, 3, 4, 5.5, 7.5, 11, 15, 18.5, 22 kW

**60 Hz:** 1.3, 1.75, 2.5, 3.5, 4.6, 6.4, 8.6, 12.5, 17, 21, 25 kW.

### NOTE!

When used with frequency converter the 22 kW motor only has 20 kW effect.

### Warranty

Extended 3-years warranty on the SolidC Centrifugal Pump range. The warranty covers all non wear parts on the condition that genuine Alfa Laval Spare Parts are used.

## Dimensions (mm)

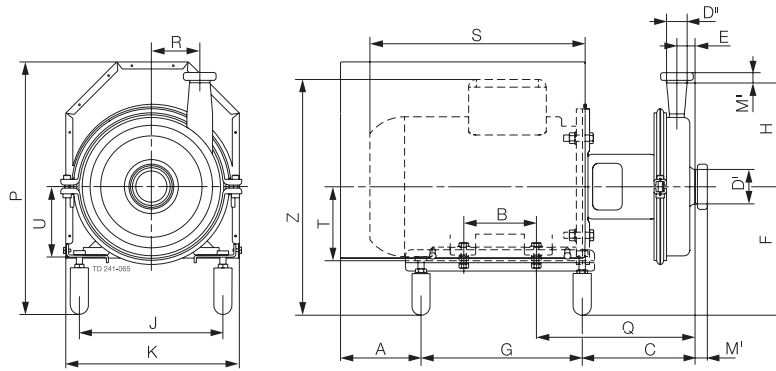

### SolidC-1

900234/3

	Weg-motor			
	kW			
	1.5	2.2	3	4
A	84	84	101	87
B	125	125	140	140
C	173	173	158	165
E	28	28	28	28
F min.	195	195	217	217
F max.	210	210	232	232
G	242	242	290	300
H	180	180	180	180
J	177	177	228	227
K	235	235	285	285
P min.	392	392	405	417
P max.	407	407	420	432
Q	231	231	236	245
R	67	67	67	67
S	254	279	316	333
T	90	90	100	112
U	93	93	115	115
Z min.	345	345	369	397
Z max.	360	360	384	412
X	305	305	305	305
Weight (kg)	38	40	52	63

### SolidC-3

	Weg-motor		
	kW		
	5.5/7.5	11/15	18.5
A	157	173	109
B	178	210	254
C	221	220	200
E	31	31	31
F min.	237	265	265
F max.	252	280	280
G	305	419	503
H	210	210	210
J	277	327	327
K	335	385	385
P min.	478	536	536
P max.	493	551	551
Q	303	323	323
R	121	121	121
S	410	488	532
T	132	160	160
U	135	163	163
Z min.	444	515	515
Z max.	459	530	530
X	390	390	390
Weight (kg)	99/102	146/153	171

## SolidC-2

	Weg-motor			
	kW			
	3	4	5.5/7.5	11
A	101	87	157	173
B	140	140	178	254
C	168	172	229	227
E	35	35	35	35
F min.	217	217	237	265
F max.	232	232	252	280
G	290	300	305	419
H	200	200	200	200
J	228	227	277	327
K	285	285	335	385
P min.	417	447	478	536
P max.	432	462	493	551
Q	243	252	311	331
R	94	94	94	94
S	316	333	410	488
T	100	112	132	160
U	115	115	135	163
Z min.	369	397	444	515
Z max.	384	412	459	530
X	349	349	349	349
Weight (kg)	55	65	94/96	140

## SolidC-4

	Weg-motor		
	kW		
	5.5/7.5	11/15	18.5/22
A	157	173	109
B	178	210	254
C	220	219	199
E	27	27	27
F min.	237	265	265
F max.	252	280	280
G	305	419	503
H	230	230	230
J	277	327	327
K	335	385	385
P min.	478	536	536
P max.	493	551	551
Q	303	323	323
R	121	121	121
S	410	488	532
T	132	160	160
U	135	163	163
Z min.	444	515	515
Z max.	459	530	530
X	410	410	410
Weight (kg)	101/103	147/154	170

## Flow chart

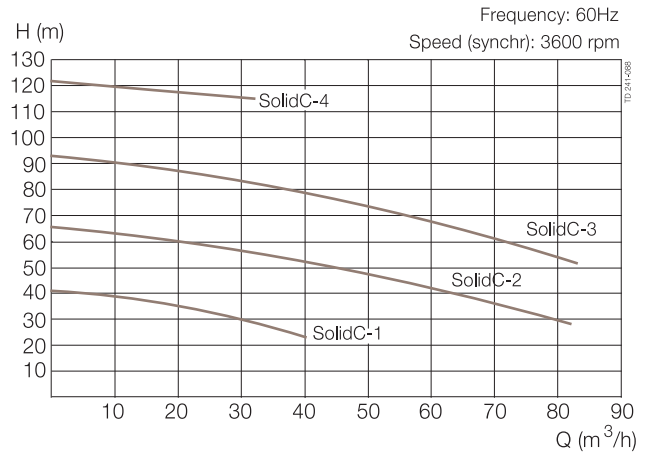
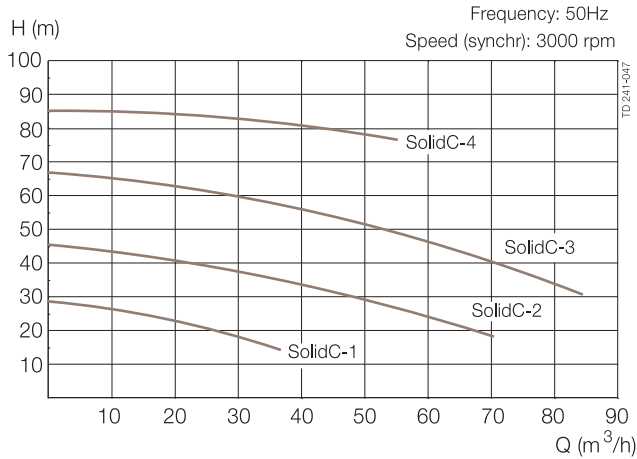

## Connections (mm) Sanitary version

### SolidC-1

D <sup>I</sup> : 51	ISO	IDF	DIN	SMS	BS	DS
D <sup>I</sup> : 38	Clamp	Male	Male	Male	Male	Male
M <sup>I</sup>	21	21	23	20	27	20
M <sup>II</sup>	21	21	22	20	27	20

### SolidC-2

D <sup>I</sup> : 63.5	ISO	IDF	DIN	SMS	BS	DS
D <sup>I</sup> : 38	Clamp	Male	Male	Male	Male	Male
M <sup>I</sup>	21	21	61	24	27	24
M <sup>II</sup>	21	21	22	20	27	20

### SolidC-3

D <sup>I</sup> : 76.1	ISO	IDF	DIN	SMS	BS	DS
D <sup>I</sup> : 38	Clamp	Male	Male	Male	Male	Male
M <sup>I</sup>	21	21	61	24	27	24
M <sup>II</sup>	21	21	22	20	27	20

### SolidC-4

D <sup>I</sup> : 76.1	ISO	IDF	DIN	SMS	BS	DS
D <sup>I</sup> : 51	Clamp	Male	Male	Male	Male	Male
M <sup>I</sup>	21	21	61	24	27	24
M <sup>II</sup>	21	21	23	20	27	20

900234/3

## Options

- A. Impeller with reduced diameter.
- B. Motor for other voltage and/or frequency.
- C. 1500 rpm. motor.
- D. Flushed shaft seal.
- E. Product wetted seals of Nitrile (NBR), Fluorinated rubber (FPM) or FEP.
- F. Rotating seal ring of Silicon Carbide.

## Ordering

Please state the following when ordering:

- Pump size.
- Connections.
- Impeller diameter.
- Motor size.
- Voltage and frequency.
- Flow, pressure and temperature.
- Density and viscosity of the product.
- Options.

## Note!

For further details, see also IM 70821.

This product has EHEDG certification

ESE00265EN 1001

The information contained herein is correct at the time of issue, but may be subject to change without prior notice.

## How to contact Alfa Laval

Contact details for all countries are continually updated on our website. Please visit [www.alfalaval.com](http://www.alfalaval.com) to access the information direct.