



PX

Commercial low silhouette air cooler - stock range

General information & application

Helpman PX coolers are commercial heavy duty air coolers for general application in small to medium size cooling and freezing rooms. The model design is characterised by a low silhouette for the efficient use of cold room space. Helpman PX coolers are available from stock.

Evaporating temp.	+5 to -40°C
Refrigerants	all H(C)FC
Capacities (SC2)	1.4 up to 8.8 kW
Air volume	1,000 up to 6,000 m ³ /h.

Coil

Coil manufactured from Cu ripple fin[®] tubes ø 1/2" and Alu-fins. Tube pitch 38 x 38 mm square.

Casing

Durable aluminium casing, white epoxy coated RAL 9003. Removable interchangeable side plates for easy access. Sufficient room for fitting the expansion valve inside casing. All models fitted with a splash guard.

Fan motors

Blow-through fans, diameter ø 254 mm. Enclosed design spray-tight fan motors, protection class IP-55. Motors equipped with a thermal safety device in the windings, connected to separate terminals in the box.

Eflo[®] refrigerant circuiting

With the Eflo[®] liquid distribution system, the refrigerant is evaporating through the coil in parallel flow with the air. Superheating takes place on the air-inlet side (highest tube temperatures!). With Eflo[®], the cooling performance improves as a result of :

- Even frost formation over the coil.
- Prolongued cooling cycle.
- Reduced defrost cycle.



PX

Certifications

All DX cooler models are "Eurovent Certify All" certified. The Alfa Laval quality system is in accordance with ISO 9001. All products are manufactured according to CE and PED rules.

Test

Design pressure 33 bar. Each heat exchanger is leak tested with dry air and finally supplied with a nitrogen pre-charge.

Options

- Electric defrost (E2)
- Special fan motors
 - 60 Hz motors

cooler model	capacity kW ¹⁾	air flow m ³ /h	coil surface m ²	weight kg	Fans					Dimensions mm					Refrig. conn.	
					nr.	capacity W nom./absorbed ²⁾		air throw m	sound pressure dB(A)	A	B	B1	B2	K	inlet OD	suction ODS
						230/1	400/3									
PX 1-7	1.4	1000	5.7	1.7	1	30/80	30/65	10	48	770	532	-	-	500	½"	½"
PX 2-7	2.9	2000	11.5	3.4	2	30/80	30/65	10	51	1270	1032	-	-	1000	½"	22 mm
PX 3-7	4.5	3000	17.2	5.1	3	30/80	30/65	10	53	1770	1532	-	-	1500	½"	22 mm
PX 4-7	6.0	4000	23.0	6.8	4	30/80	30/65	10	54	2270	2032	-	-	2000	½"	28 mm
PX 5-7	7.4	5000	28.7	8.5	5	30/80	30/65	10	55	2860	2540	1502	1038	2500	½"	28 mm
PX 6-7 ³⁾	8.8	6000	34.5	10.2	6	30/80	30/65	10	56	3360	3040	1502	1538	3000	½"	35 mm

1) Capacities R-404A / R-507A (t₀ = -8 °C, DT₁ = 8K, lightly frosted coil).

2) Fan power is given per motor. Absorbed fan motor energy is measured under laboratory conditions at ambient temperature 20°C. Values may vary depending on local conditions.

3) 3 mounting channels

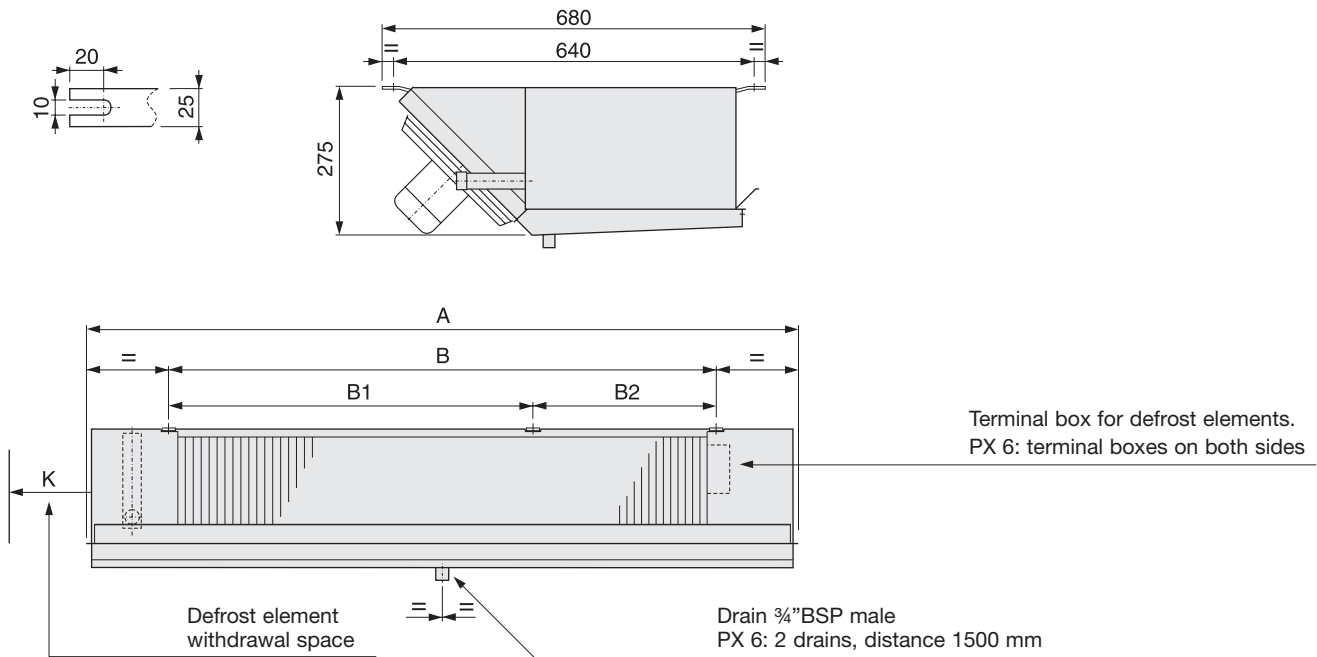

Terminal box for defrost elements.
PX 6: terminal boxes on both sides

Defrost element withdrawal space

Drain ¾" BSP male
PX 6: 2 drains, distance 1500 mm

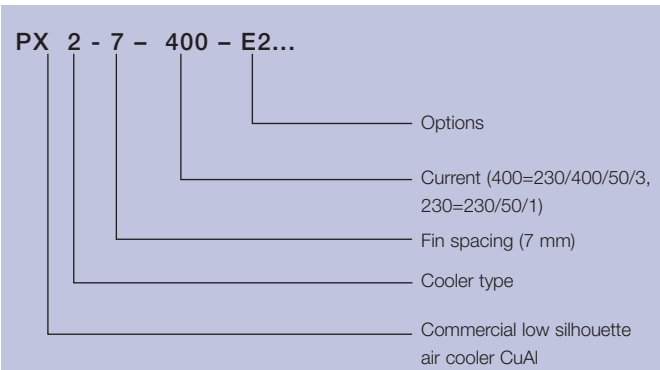

Benefits

- Available from stock.
- Low silhouette for efficient use of cold room space.
- Heavy duty coil & casing materials, resulting in a long operational product life.
- Eflo® refrigerant circuiting for higher effective cooling capacity.
- Reliable performance, Eurovent certified.
- Easy-install.
- Energy efficient - low total cost of ownership.
- Two-year product guarantee.

ERC00174EN 0905

Alfa Laval reserves the right to change specification without prior notification.

How to contact Alfa Laval

Up-to-date Alfa Laval contact details for all countries are always available on our website at www.alfalaval.com



Packaging - Processing
Bid on Equipment
1-847-683-7720
www.bid-on-equipment.com