



Alfa Laval Module M37

M37

The Module M37 is specifically designed for ultrafiltration and microfiltration of highly viscous products (50 cP) and fermentation broths. The module is ideal for various uses in industries such as pulp and paper, biotechnology and pharmaceuticals, as well as food and beverages.

The Module M37 is developed to meet the future demands for optimized flow dynamics, low energy consumption and low-pressure operation. All materials are in compliance with FDA regulations. This membrane module is particularly suited for:

Pulp & Paper

- Spent sulphite liquor
- Black liquor
- Lignin concentration
- Kraft bleach effluents
- Colour removal
- Lignosulphonate concentration

Biotech & Pharma

- Antibiotics - whole broth clarification
- Amino acids/organic acids - whole broth clarification
- Dextranes - concentration of HMW dextranes

Food & Beverage

- Dairy - cultured milk concentration
- Gums - xanthan and pectin concentration
- Protein - concentration of soya, whole egg, gelatine etc.
- Beer - beer yeast concentration
- Sugar - clarification of saccharification liquid (HFCS)
- Juice - clarification of orange juice, apple juice etc.



The Module M37 is available with membrane areas of up to 27 m²per module. It can be equipped with all types of flat sheet UF and MF membranes. The Module M37 for ultrafiltration and microfiltration comes in the following standard sizes defined by membrane area:

Membrane area	4.5 m ²	6.6 m ²	9.0 m ²	13.5 m ²	18.0 m ²	22.5 m ²	27.0 m ²
Length A, mm	691.0	811.0	961.0	1241.0	1521.0	1791.0	2071.0
Shipping weight, kg	205.0	215.0	230.0	255.0	280.0	310.0	335.0
Shipping volume, m ³	0.6	0.6	0.8	1.0	1.0	1.4	1.4

Operating principles

The module can operate at temperatures up to 80°C (176°F), pressures up to 15 bar (217 psi), and pH between 1 and 14. The entire range of flat sheet membranes for ultrafiltration and microfiltration can be used. Please consult the Alfa Laval product descriptions for flat sheet membranes for details of temperature, pressure and pH limits set by the membranes.

The Module M37 comprises:

- Frame and fittings all made of stainless steel
- Support plates, end plates, and permeate collecting tubes made of polysulphone (PSO)
- Gaskets made of nitril rubber
- Permeate hoses made of silicone rubber
- Frame: The module is mounted on adjustable legs and the inlet/outlet flanges are connected to each other by means of horizontal bolts. One end flange and the membrane support plates can slide along the bolts.
- The Alfa Laval hydraulic tool kit type T37, flat sheet membranes and lock rings must be ordered separately

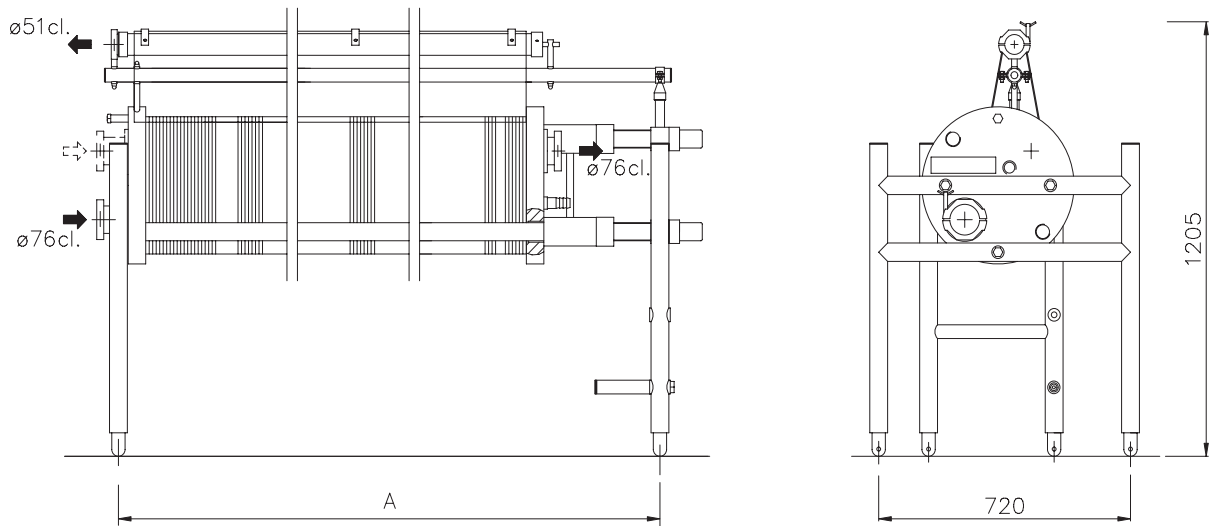

Module data

Module designation	M37 - (m ² of membrane area)-(number of sections)-(type of Alfa Laval membrane)
Generic design	Plate-and-frame type cross-flow membrane filtration module
Plate-and-frame design	M37 - polysulphone (PSO) plates in M37 frame
Membrane area	4.5-27 m ²
Membrane type	All Alfa Laval flat sheet MF and UF membranes
Number of sections	1 or 2-3-4-5 etc. uniform sections connected in series
Number of section plates	1 less than the actual number of sections
Number of support plates	1 per 0.11 m ² of membrane area installed
Number of end plates	2 per module
Number of membrane sheets	2 per support and section plates installed
Cross-flow configuration within sections	Parallel membrane sheets of 0.055 m ²
Liquid capacity	2.3 l/m ² of membrane area installed
Weight, empty/dry	175 kg + 5.8 kg/m ² of membrane area installed
/ water quality specification.	

Operating data

Cross-flow range (per plate in one section)	20-35 l/min.
Inlet pressure	Max. 15 bar
Differential pressure	0.2-2 bar/section
Viscosity range, apparent	50-250 cP
Max. temperature	80°C
pH range	1-14
Plate stack pressure/temperature	15 bar at 0-40°C sloping to max. 5 bar at 80°C
Plate stack compression force	Max. 240 kN (matching Alfa Laval hydraulic tool kit to be used)
Max. back pressure at permeate tube outlet!	0.1 bar at static and 0.3 bar at dynamic conditions

Materials data

External steel	Stainless steel (min. AISI 304 type)
Internal/product wetted	Acid resistant (min. AISI 316 type)
Support, section, and end plates	Polysulphone (PSO)
Permeate tube and connector	Polysulphone (PSO)
Permeate hose	Silicone rubber (Si)
Gasket and o-ring	Nitril rubber (NBR)
Membrane lock ring	Polypropylene (PP)
Membrane sheet	According to Alfa Laval product descriptions
Connections at cross-flow in/outlets	DN 76.1, ISO 2852 clamp flange and ring
Connections at two permeate outlet tubes	DN 51, ISO 2852 clamp flange and ring

Accessories

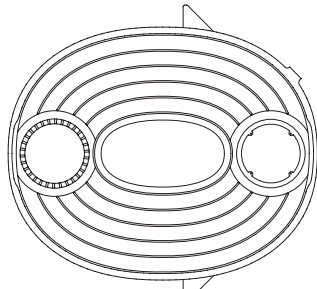

101603

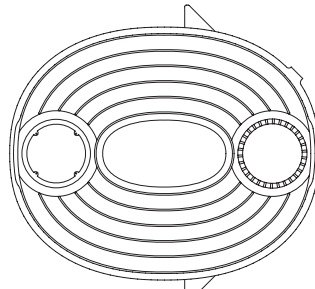

101604

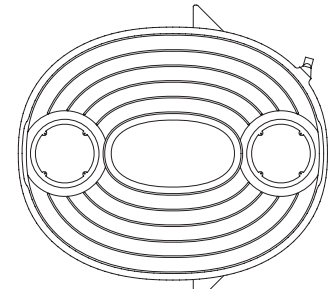

101650

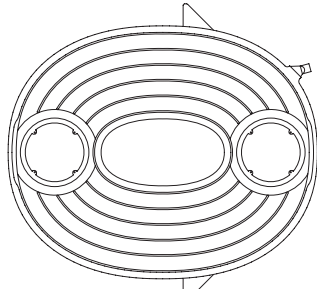

101651

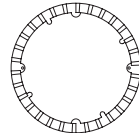

101728

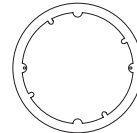

101718

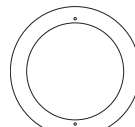

101735

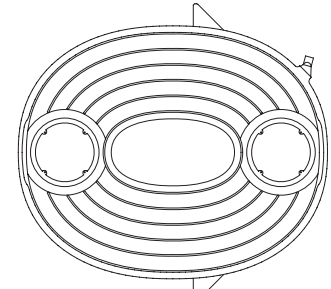

101781/101791

Designation	Material	Code no.
End plate, top	Polysulphone	101603
End plate, bottom	Polysulphone	101604
Membrane support plate, type 0	Polysulphone	101650
Membrane support plate, type 1	Polysulphone	101651
Passage ring	Polypropylene	101728
Lock ring	Polypropylene	101718
Section plate, blue outlet	Polysulphone	101781
Section plate, grey outlet	Polysulphone	101791
Stop disc	Stainless steel	101735

ESE00748EN 0901

The information contained herein is correct at the time of issue, but may be subject to change without prior notice.

How to contact Alfa Laval

Contact details for all countries are continually updated on our website. Please visit www.alfalaval.com to access the information direct.